



This manual has been scanned by the
Vickers MG Collection & Research
Association

www.vickersmachinegun.org.uk

If it is of use, please make a donation at:

https://www.paypal.com/cgi-bin/webscr?cmd=s-xclick&hosted_button_id=NKSHEDAMHTJ3G

SMALL ARMS
TRAINING
VOL. II
—
1931

Glyn, Mills & Co.



(Established 1855)
Registered with unlimited liability 1885
Incorporating

CHILD & CO. and HOLT & CO.
(Est. before 1800) (Est. 1800)

BANKERS

OFFICIAL ARMY AGENTS

42, GRACECHURCH STREET, LONDON, E.C.3

*(Temporary Head Office during rebuilding of
67 Lombard Street, E.C.3)*

Childs Branch - - - - 1, Fleet Street, E.C.4

Holts Branch - Kirkland House, Whitehall, S.W.1

Current and Deposit Accounts opened on the usual terms.

The Bank has Agents or Correspondents in all the principal cities and towns throughout the World, and can provide Banking facilities wherever desired.

Letters of Credit and Circular Notes issued, Currency Drafts supplied and Remittances and Telegraphic Transfers made to all parts.

Foreign Currency Accounts opened.

Securities held on Customers' behalf.

Dividends, Annuities, etc., received, and Coupons collected.

The Bank has a special department to advise and assist customers on questions relating to Income and Sur-Tax.

Navy and Prize Agents. Salvage claims preferred.

**The DUTIES OF EXECUTORS and TRUSTEES
UNDERTAKEN.**

Full particulars can be obtained on application to:

THE TRUSTEE DEPT. Kirkland House, Whitehall, S.W.1

HOWARD HOTEL, LONDON



MODERN AND UP-TO-DATE

Why not stay at a first-class hotel, where every room is centrally heated, fitted with running hot and cold water and telephone, and which provides the finest foods and wines with perfect service. Elegant suites, and bedrooms with private bathrooms. Send for Illustrated Booklet. Bedroom with full breakfast from 12/6.

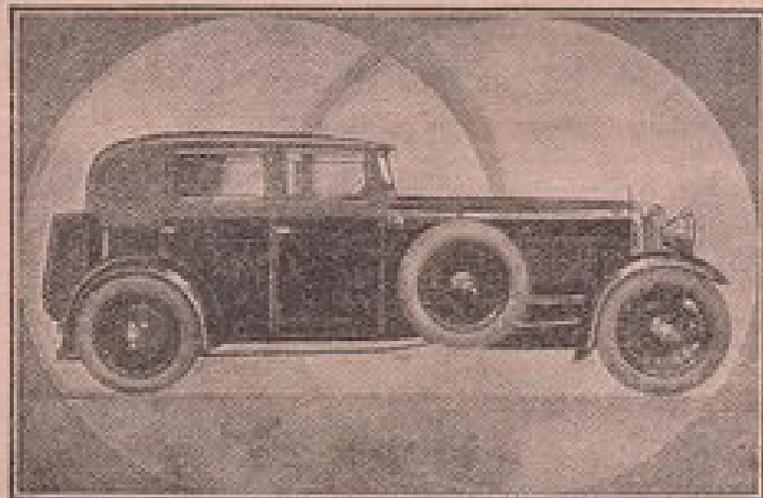
MAKE THE HOWARD YOUR LONDON HOME

Telephone: Temple Bar 4400

Wires: Howhotel, London.

NORFOLK STREET, STRAND, LONDON, W.C.2

www.vickersmachinegun.org.uk



SPEED, endurance, and sturdiness of construction are typical British qualities inherent in the all-British Lagonda—but we would not have you take them for granted. Satisfy us by satisfying yourself, after personal trial, that the Lagonda fulfils all that is demanded of it.

LAGONDA

2-Litre Chassis	£555
2-Litre Chassis, Supercharged	£610
3-Litre 6-Cyl. Chassis	£775
3-Litre Special Chassis.	£835

Dunlop Tyres, Ferric finish and Acetex Safety Glass standard to the All-British Lagonda.

LAGONDA LTD. :: STAINES :: MIDDLESEX

G.F.A. 43

£10

OFFICIAL COPY

[Notified in Army Orders for September, 1931

[Crown Copyright Reserved

26
Manuals
872



SMALL ARMS TRAINING

VOLUME II

LIGHT AUTOMATIC, GRENADE
AND
SMALL ARMS ANTI-AIRCRAFT

1931

LONDON:

PUBLISHED BY HIS MAJESTY'S STATIONERY OFFICE

To be purchased directly from H.M. STATIONERY OFFICE at the following addresses:
Admiral House, Kingway, London, W.C.2; 100, George Street, Edinburgh;
York Street, Manchester; 1, St. Andrew's Crescent, Cardiff;
25, Duncannon Square West, Belfast;
or through any Bookseller.

1931

Price 1s. 6d. net

57-282-0-31

ORIGINAL COPY

THE WAR OFFICE
30th September, 1931.



By Command of the Army Council,

J. J. Greedy

THE WAR OFFICE,
30th September, 1931.

CONTENTS

CHAPTER I

LEWIS GUN TRAINING (GROUND)

Sec.	PAGE
1. General	1
2. System of training	5
3. Magazine filling	6
4. Holding, loading and unloading	10
5. Sight setting, aiming and firing	18
6. Stripping and assembling (elementary)	25
7. Stripping and assembling (component parts)	32
8. Care and cleaning	38
9. Elementary mechanism; backward and forward action	46
10. Points before, during and after firing	52
STOPPAGES	
11. Immediate action	58
12. Mechanism of immediate action stoppages	68
13. Probable stoppages and mechanism concerned	76
14. Possible stoppages and mechanism concerned	82
15. Additional mechanism	90
HANDLING	
16. General	95
17. Elementary handling (Part I)	96
18. Advanced handling (Part II)	109
19. Section handling (Parts III and IV)	113

TESTS OF ELEMENTARY TRAINING—LEWIS GUN

Sec.	PAGE
20. General instructions	117

CHAPTER II

GRENADE TRAINING

21. Definitions	123
22. General	124
23. System of training	129
24. Firing instruction	132
25. Throwing instruction	146
26. Firing dummy grenades	154
27. Tests of elementary training	157
28. Training with live grenades	158
29. Preparation of demolition sets and the destruction of blinds	166
30. Reporting failures and defects	172
31. Precautions in handling live material	173
32. Ballistite grenade cartridge	175
33. Precautions against gas	175

CHAPTER III

SMALL ARMS ANTI-AIRCRAFT TRAINING

GENERAL CONSIDERATIONS

34. Responsibility of commanders	176
35. Methods of air attack and value of small-arm fire	176
36. General principles of small-arm defence	177

GENERAL INSTRUCTIONS FOR TRAINING

Sec.	PAGE
37. Personnel to be trained	178
38. Primary considerations in training	179
39. Recognition	180
40. Ranging	181
41. Warning and air sentries	183

METHOD OF TRAINING

The rifle

42. Subjects to be taught	184
43. Aiming instruction	184
44. Firing instruction	189
45. Firing with .22-inch ammunition	192
46. Fire control	193
47. Fire discipline training	195
48. Strengthening exercise	198

The anti-aircraft light automatic

49. Subjects to be taught	200
50. Aiming instruction	200
51. Fire control	209
52. Elementary handling	210
53. Criticism of groups	219

The spotlight projector

54. The spotlight projector (rifle and light automatic)	226
--	-----

TESTS OF ELEMENTARY TRAINING

55. Standard tests	230
---------------------------	-----

GRENADES		PAGE
PLATE		
25.	Grenade, percussion 2-inch No. 54 (Section) ...	297
26.	" " " " No. 54 ...	298
27.	Detonator for grenade No. 54 ...	302
28.	2-inch Discharger, for attachment to rifles, No. 1	309
29.	Grenade 2-inch 303-inch rifle, smoke ...	314
30.	No. 36 H.E. grenade ...	317
31.	2½-inch Discharger, for attachment to rifles, No. 1 ...	331

ANTI-AIRCRAFT ACCESSORIES, ETC.

32.	Anti-aircraft portable mounting ...	339
33.	Aiming rest adapted to take a Lewis gun ...	341
34.	Model aeroplane, with pole and stand ...	343
35.	Projector, spotlight ...	346
36.	" " " " bracket attachments for rifle and Lewis gun ...	347
37.	Moving target for spotlight projector ...	355

SMALL ARMS TRAINING

VOLUME II

LIGHT AUTOMATIC, GRENADE AND SMALL ARMS ANTI-AIRCRAFT

1931

CHAPTER I

LEWIS GUN TRAINING (GROUND)

1. *General*

1. The general principles governing the employment of the light automatic section in war are dealt with in Field Service Regulations, Vol. II; Infantry Training, Vol. II; and Infantry Section Leading.

2. The chief characteristic of this weapon is its power of delivering heavy bursts of fire with the employment of a few men. Its effective range is the same as the rifle.

3. It is a shoulder-controlled weapon, air cooled and capable of a high rate of fire. To avoid overheating, strain, excessive expenditure of ammunition and, at the same time, to produce the necessary volume of fire, it is best to fire in bursts of four or five rounds.

The accuracy of the gun permits of only a small margin of error in aiming, range estimation, or allowance for the effect of atmospheric conditions. Accurate observation of fire is, therefore, essential; if less than four or five

rounds are fired in a burst, observation will be possible only under the most favourable circumstances.

4. Taking into account the time required for changing the magazines and for aiming between bursts of fire, an average of 150 rounds a minute can be maintained by a trained man. This high rate of fire does not necessarily produce the best results; bursts of fire with pauses between them are often more destructive as well as disconcerting to the enemy's morale.

5. The sections of this chapter set out the detailed instructions for the training of the individual either in handling the gun or performing such other duties as he may, as one of the section, be called upon to perform.

6. i. To ensure that the light automatic section will fulfil its role in war, the personnel must be trained so that each individual is capable of performing the following duties actually concerned with the handling of the gun:—

- (a) To prepare the gun for firing and maintain it in action.
- (b) To carry the gun and get it quickly into action on any nature of ground.
- (c) To fire accurately at various rates up to 150 rounds a minute according to the requirements of various types of targets likely to be encountered in battle.
- (d) To observe fire and correct its application accordingly.
- (e) To fire with effect at low-flying aircraft. (See Chapter III.)

(f) To perform the duties assigned to any "number" in a light automatic section.

ii. The subjects in which a man requires instruction in the light automatic and the order in which they should be taught are as follows:—

Magazine filling	Lesson	1
Holding, loading and unloading	"	2
Sight setting, aiming and firing	"	3
Stripping and assembling (elementary)	"	4
Stripping and assembling (component parts)	"	5
Care and cleaning	"	6
Elementary mechanism, backward and forward action	"	7
Points before, during and after firing	"	8
Elementary handling—Duties of Nos. 1 and 2 (Part I)	"	9
Immediate action	"	10
Reasoning causes of stoppages cured by I.A.	"	11
Probable stoppages	"	12
Advanced handling—Duties of Nos. 1 and 2 (Part II)	"	13
Possible stoppages	"	14
Additional mechanism	"	15
Section handling—Duties of Nos. 3, 4, 5 and 6 (Part III)		
Packing of limber and limber drill *		
Section handling (Part IV), section duties		

* Alternatively:—

Duties of Nos. 3, 4, 5, 6, 7 and 8	
Loading of pack animal and pack drill	

7. i. In order to obtain full effect from the accuracy of the gun, the importance of *correct holding* must be insisted on from the first. The best test of correct holding will be found from the results obtained when firing ball ammunition, and no man should be allowed to fire at longer ranges until he can group to 4 inches at 25 yards, or 16 inches at 100 yards when firing service bursts. Instruction in correct holding cannot, however, be delayed until this period of training, and any tendency to loose holding even during the most elementary instruction must at all times be checked, otherwise failure in marksmanship will result.

ii. During early training men should be taught to *feel* a pull on the bipod legs to ensure that the bipod is supporting the gun correctly. The pull should, however, not be over-emphasized as, with more experience, a firer will get more accurate shooting when the bipod legs are kept vertical, so as to allow a certain amount of backward and forward movement of the gun during firing.

8. To maintain the gun in action and so avoid loss of fire power, a high standard of training in locating and remedying stoppages is essential. To achieve this, the system of training should be such as to develop in each individual a mechanical aptitude. This should enable the man to *reason* the cause of any unforeseen stoppage and thus ensure that the gun is not out of action at some critical period through a trifling cause. It will also have the advantage of rendering him more quickly adaptable to any other weapon of a mechanical type in which he may subsequently have to be trained.

2. System of training

1. The principles of instruction in the light automatic are laid down in Vol. I, 1931, Sec. 3. The following paragraphs are included for ready reference and in amplification of the above.

2. Since there is only one weapon for each squad, the sequence of instruction in the light automatic will vary slightly from the normal, *i.e.* the rifle. The development of a man's powers of reasoning will be achieved by the instructor obtaining from him, by means of question and answer, the required information regarding the condition of the gun and the action of the mechanism.

3. *The sequence of instruction will be :—*

- i. Preliminaries.
- ii. Statement of the scope and object of the lesson.
- iii. Demonstration; explanation.
- iv. Interrogation.
- v. Execution.
- vi. Repetition.

4. The following points will be noted :—

- i. *Preliminaries.*—These will include inspection of gun, magazines and dummies for reasons of safety.
- ii. *Demonstrations.*—All include a certain amount of *explanation*. Certain actions may have to be repeated to make them clear. When dealing with the manner in which any parts function, such parts will be named and described as necessary. During instruction on

mechanism, large-scale coloured diagrams will be found useful.

- iii. *Interrogation*.—If, at this stage of a lesson, it becomes evident that those under instruction have not grasped some particular action, the instructor should revert to further demonstration and explanation to make the point clear.
- iv. *Execution*.—When a squad is practising either singly or in pairs, the remainder will watch the action of the man or men at the gun. The instructor will question them as to the accuracy of the actions being performed. All executive orders given to a No. 1 are to be repeated by him. On completion of this stage the instructor will mention the conditions of the *standard test*, if any, which will be applied later.

3. Magazine filling

LESSON 1.—MAGAZINE FILLING

1. Preliminaries :—

- i. Stores required. One *magazine*, one *loading handle* (if available) and one charger for each man. Ground sheets and dummy cartridges.
- ii. Squad seated in convenient position.

2. Sequence of instruction :—

- i. Show *magazine*. State that it holds 47 rounds and that the object of the lesson is to teach how it is filled and emptied.

ii. Demonstrate, naming each phase :—

(a) *Filling magazine.*

Position of man, *magazine* and ammunition.

Use of *loading handle*.

Examination of *magazine*.

Inserting rounds.

Instructor also uses his hand and then a charger, stating that both methods may be used whenever loading handles are not available.

(b) *Emptying magazine.*

Position of *magazine*.

Use of *loading handle*, hand or charger.

Removing rounds.

- iii. Squad imitates the instructor; those men having no *loading handle* will use the hand or a charger.

Filling :—

(a) Place rounds in a clean place.

(b) Insert the *loading handle* or charger in the *socket* and press home, releasing *magazine catch*.

(c) Examine the *magazine* for damage to the *retaining plates* and *separating pegs*, see that the *outer pan* is not distorted and rotates freely round *centre block*, that the *magazine catch* is working and that the *magazine* is clean.

(d) Place *magazine* on the thigh, one hand

on the *loading handle*, the other insert rounds.

- (e) Insert rounds one at a time, without leaving spaces, and ensure that the rims are behind the *retaining plates* and the bullets between the *separating pegs*.
- (f) After inserting each round rotate the *outer pan* until the cartridge passes under the lip of the *centre block*.

To fill by hand :—

- (g) Hold the *magazine* in the left hand with the thumb round the *outer pan*, press the *magazine catch* with the first or second finger. With the right hand place a round in the *magazine* as already taught, place the thumb of the right hand on the sloping surface of the *centre block* and rotate the *centre block* until the round passes under the lip.

Emptying :—

- (h) Position of *magazine* as for filling.
- (j) Insert *loading handle* or charger in the *socket*.
- (k) Rotate the *magazine* slowly, removing each round as it becomes disengaged.
- (l) Having collected 4 or 5 rounds in the hand, put them down in a clean place.

To empty by hand :—

- (m) Hold the *magazine* as when filling, place the thumb of the right hand on the lip of the *centre block*, rotate the *centre block* and empty as already taught.

iv. The instructor questions the squad on points given in sub-para. iii, above, and gives reasons for certain items as follows :—

- (a) To prevent grit or dirt entering the parts of the gun.
- (b) Unless the *handle* is pressed fully home, the *magazine catch* will not be released.
- (c) A damaged *magazine* will cause the gun to stop when firing. Dirt may also cause it to stop.
- (d) The most convenient position for quick filling.
- (e) If spaces are left between rounds, the feeding of the gun will be stopped. Unless the rim of a round is behind the *retaining plates*, the round will be crooked and will jam the *magazine*. By putting the bullet between the *separating pegs* the round is kept straight and an even feed ensured.

v. Further practice as necessary in all methods.

4. *Holding, loading and unloading*

LESSON 2.—HOLDING, LOADING AND UNLOADING

The sequence of instruction will now be modified in accordance with Vol. I, 1931, Sec. 3.

1. *Preliminaries.*

- i. Stores required.—Gun, magazines, loading handle, dummies, ground sheets.
- ii. Inspect gun and dummies.
- iii. Show a *Lewis machine gun*. State that it is commonly known as the *light automatic* and is the same calibre as the rifle, and that the lesson is holding, loading and unloading.

Stage I. The firing position in the open and how to hold the gun

2. *Sequence of instruction.*

- i. Explain that the *light automatic*, unlike the rifle, has little shock of recoil, but the automatic action of the gun sets up considerable vibration which, unless controlled, throws the gun off its alignment. This control can only be effected by correct holding, which is essential to accurate shooting.
- ii. Instructor demonstrates *holding*, giving detail of various points to note.
 - (a) From position of attention behind gun instructor lies down on giving the order "Position behind gun." Except

that there will be no half-turn to the right the method will conform to that of the rifle.

- (b) Position behind gun.—Body and legs straight behind gun, both elbows on the ground.
- (c) *Bipod legs* firmly fixed in the ground with *shoes* towards firer.
- (d) Position of hands before raising *butt*.—Left hand back up, round the *small of the butt*, thumb underneath. Right hand, forefinger off the *trigger*, remaining three fingers holding the *pistol grip*, second being close up to the *trigger guard*. Thumb on left side of *pistol grip*.
- (e) Position with *butt* in shoulder (*see Plate 1*).—Left hand gripping the *small* and exerting a steady *downward, backward* and *inward* pressure. Right hand, fore-finger round *trigger*, gripping with the remaining fingers and thumb and exerting a steady *backward* and *inward* pressure. The pull against the bipod legs must not be excessive. (*See Sec. 1, 7, ii.*)
- (f) On completion of demonstration, instructor on giving the order "Change round" returns to position of attention by pressing up off the ground with both hands.

PLATE I

LEWIS GUN—CORRECT HOLD

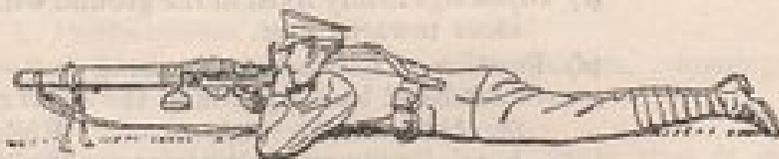


FIG. 1

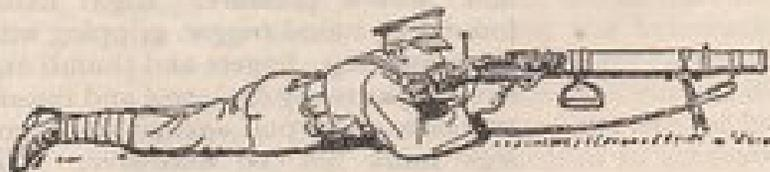


FIG. 2

iii. Instructor questions the squad on points given in sub-para. ii, above, and gives reasons for certain items as follows:—

(b) To enable the firer to exert an even pressure with both arms, having both elbows firm.

(c) Steadiness. The height of the *legs* must suit the firer.

(e) *Backward* pressure checks the backward and forward vibrations, *downward* pressure tends to prevent upward and downward vibrations, while the *inward* pressure checks lateral vibrations. This combination of pressure against the shoulder produces a locking effect which enables the aim to be maintained whilst firing.

(f) Both hands on the ground to ensure pressure is not put on the gun.

iv. Squad practises—each man in turn.

v. Further practice as necessary.

Stage II. Loading and unloading

3. Sequence of instruction.

i. State scope and object of lesson.

ii. Demonstrate, naming each phase:—

(a) "Load"

Position of *cocking handle*.

Putting on *magazine*.

Rotating *magazines*.

Pulling back *cocking handle*.

(b) "Unload"

Removing magazine.

Clearing gun.

"Gun clear."

iii. Repeat demonstration, giving detail of various points to note :—

Loading.

- (a) On command "Load" adopt the position behind the gun as taught.
- (b) Ensure the *cocking handle* is forward. In case of recruits doing this for first time they may be allowed to look as well as to feel.
- (c) Place *magazine* on *magazine post*, ensuring that the *thumb piece* of the *spring catch* is to the right.
- (d) Press *magazine* down gently until the *catch* engages inside the *magazine post*.
- (e) Rotate the *magazine* as far as it will turn in the feeding direction.
- (f) Pull back the *cocking handle*. The gun is now loaded with a round in the *feedway* ready to be moved to the *chamber*. Compare it with the position of a cartridge in the chamber of a loaded rifle. In the light automatic the round is in the *feedway* and the breech is open.

Unloading.

- (g) Press the *magazine catch* to the right with the thumb. Lift off the *magazine* and

pass it, *centre block* upwards, under the gun ready for returning to the *carrier*.

- (h) Raise the *butt* into the shoulder, holding the gun as already taught.
- (i) Fire the round, pull back the *cocking handle*, press the *trigger*.
- (j) To ensure the gun is clear always pull back the *cocking handle* until no round is ejected.
- (k) Place both hands on the ground, press up off the hands and assume the position of attention. Report "Gun clear."

iv. Instructor questions the squad on points given in sub-para. iii, above, and gives reasons for certain items as follows :—

- (d) Undue pressure on placing *magazine* on *post* will cause damage.
- (e) Unless this is done before pulling back the *cocking handle* the gun will not be loaded.
- (g) *Centre block* upwards to keep ammunition free from dirt. *Magazine* passed under the gun for quickness in changing.
- (j) Safety.

v. Squad practises—each man in turn. Before doing so the instructor will explain that the commands "Load" and "Unload" will be repeated by the man, and that this rule applies to all commands and fire orders given

to the firer of the *light automatic* under all circumstances.

- vi. Instructor gives condition of test (Sec. 20).
- vii. Further practice as necessary.

Stage III. Unloading without firing

4. Sequence of instruction.

i. State that the method of unloading already taught is normal on service, but in peace time on the range the method known as *unloading without firing* will be used.

ii. Instructor gives order "Load" followed by "Without firing—unload" and demonstrates, naming each phase:—

Removing magazine.

Pressing down the round, using the nose of a bullet.

Drawing round forward.

Control of *cocking handle* and *trigger*.

Cocking the gun.

Clearing gun.

"Gun clear."

iii. Repeat demonstration, giving detail of various points to note:—

(a) *Removing magazine*.—As for service unloading.

(b) *Pressing down round*.—Place bullet across the base of the cartridge, depressing the base until front end rises.

(c) Draw the bullet forward until the point is resting on the front of the opening of the *feed arm*.

(d) *Control of cocking handle and trigger*.—Hold the *cocking handle* with the right hand. Press the *trigger* with the left hand and allow the *cocking handle* to go forward slowly until the point of the bullet turns over to the right.

(e) Cock the gun.

(f) Remove the round if not already cleared.

(g) Press the *trigger*.

(h) Clear the gun by again pulling back the *cocking handle* and pressing the *trigger*.

(i) Report "Gun clear."

iv. Instructor questions the squad on points given in sub-para. iii, above, and gives reasons for certain items as follows:—

(b) The bullet is placed *across* the base of the cartridge to prevent the possibility of it slipping off, thus causing delay.

(d) The right hand controls the *cocking handle* when the *trigger* is pressed to prevent the round becoming jammed between the *feed arm* and *body*, also to prevent risk of another round being fired.

v. Squad practises.

vi. Instructor gives conditions of test (Sec. 20).

vii. Further practice.

5. *Sight setting, aiming and firing*

LESSON 3.—SIGHT SETTING, AIMING AND FIRING

1. *Preliminaries.*

- i. Stores required.—Gun, magazines, aiming disc, landscape target, ground sheets and magazine carrier.
- ii. Put up landscape target with representative target pinned on. Inspect gun and dummies.

2. *Sequence of instruction.*

- i. State scope of lesson and that its object is the same as with the rifle. Sight setting to obtain direction and elevation; to aim correctly at any target however difficult to see, and to fire the gun in the open.
- ii. Instructor demonstrates sight setting, aiming and firing, naming each phase on giving order:—

“Load”

Loading.

“ . . . hundred ”

Sight setting.

Aiming.

Firing.

“Unload”

Unloading.

Lowering backsight.

“Gun clear.”

Stage I. Sight setting

(Gun unloaded)

3. *Sequence of instruction.*

- i. Instructor demonstrates *sight setting*, giving details of various points to note.

(a) *The backsight.*—The markings of hundreds of yards on the *leaf* of the *backsight* differs from the rifle. Odd numbers are on the right, even on the left. Fifties are not shown. The lines for lower ranges are closer together than for longer ones and are not evenly spaced as on the rifle.

(b) *To adjust the backsight* raise the *leaf* slightly, rotate the *milled head* until the line on the *slide* is level with the line on the *leaf* immediately below the figure indicating the distance required. Having adjusted the sight, raise the *leaf* to its fullest extent.

- ii. Instructor questions squad on above points.
- iii. Squad practises adjustments of odd and even numbers and fifties. Each man starts with the *backsight* down.
- iv. Instructor gives conditions of test (Sec. 20).

Stage II. Aiming

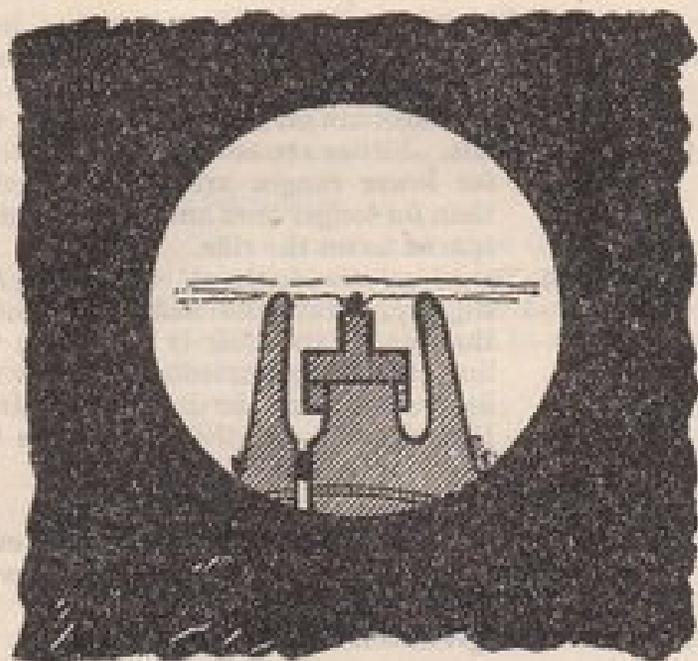
(Gun unloaded)

4. *Sequence of instruction.*

- i. State that principles are the same as with the

PLATE 2

LEWIS GUN—CORRECT AIM



- rifle. The first and second rules are the same, but the third is different because of the aperture backsight. The foresight is similar to that of the rifle.
- ii. The rules of aiming are :—
 - (a) *Sights upright.* If difficulty is found in doing this, loosen the *band screw*.
 - (b) The left eye if, as is normal, the man shoots from the right shoulder, must be closed. In the opposite case the right eye must be shut.
 - (c) Look through the aperture at the mark. Align the top of the foresight on the lowest central portion of the mark, the point of contact thus made being in the centre of the aperture. When the sights are thus aligned focus the aiming mark.
 - iii. The instructor will draw a diagram as shown in Plate 2.
 - iv. The instructor lays a correct aim, resting the gun in any convenient way. The squad, each man in turn, resting his head and eye in a correct firing position, views the aim. The instructor then demonstrates how to use the elbows as a means of obtaining elevation or depression of aim. He will also explain that if additional elevation is needed it can be obtained by lengthening the legs of the tripod.
 - v. Instructor questions the squad on the above points.

- vi. Squad practises, each man in turn aiming, elevating and depressing, the instructor using an aiming disc.

Stage III. Firing

5. Sequence of instruction.

- i. Instructor loads the gun, adjusts sights, and demonstrates firing, giving detail of various points to note.

- (a) Unlike the rifle there is only one pressure on the trigger. This is taken on the command "Fire." As with the rifle the trigger must be pressed by a squeezing action of the whole hand.
- (b) A pressure of half a second will fire a burst of four or five rounds. This is the normal service burst.
- (c) After releasing pressure on the trigger observe the strike of the shots with minimum movement of the head.
- (d) Make any necessary alteration of sights or point of aim.
- (e) Re-aim and fire as before.
- (f) The sequence of firing the gun is :
Aim, press, release, observe, and then repeat.
Correct holding must be maintained throughout.
Normal rate of fire is five to six bursts a minute.

- ii. Instructor questions the squad on the above points and gives reasons for :—

- (b) Service bursts of four to five rounds.
Ammunition supply will not permit of firing the gun at 500-600 rounds a minute, which is the rate at which the gun fires.
Prevents overheating of the gun.
Vibration of the gun makes holding an accurate aim with larger bursts very difficult.
Bursts of less than four to five rounds renders observation of fire too difficult.
- (c) Observation is the best method of checking the accuracy of fire. Bursts of fire as produced by the light automatic provide a satisfactory means of doing this.

- iii. Squad practises, instructor giving command "Aim, press, release, observe, aim," and repeat in that sequence.

Having cleared the gun, instructor using an aiming disc then tests each man's aiming and trigger pressing.

The gun will be cocked each time after a man observes before he re-aims. Any apparent fault in holding will be checked.

Instructor gives conditions of test (Sec. 20).

- iv. Squad practises complete lesson from command "Load" to the reporting "Gun clear."

Instructor explains that rapid fire is the same as slow fire, except that in the former there is only sufficient interval between bursts to observe and aim.

Standard to be reached, 150 rounds a minute.

In rapid fire an expert gunner will fire bursts of more than four or five rounds, the length of the burst depending on the capabilities of the L. A. gunner.

- v. Instructor finally questions squad on method of aiming and firing at moving ground targets as taught in *rifle* instruction. Explains that the same "standard lead" method should be applied in the case of the Lewis gun except that, with the light automatic, it is not possible to swing with a crossing target. For such targets it will be necessary to select some spot in front of the target and on its line of movement. Then, just as the centre of the target is about to be covered by the inner foresight protector, fire a long burst of eight to ten rounds. While doing so, a slight swinging movement can be imparted to the light automatic by a twisting motion of the shoulders, but the correct grip with both hands must be maintained and the elbows must not be moved. A succession of such bursts should be fired, a fresh point ahead of the target being selected each time.

6. Stripping and assembling (elementary)

LESSON 4.—STRIPPING AND ASSEMBLING (ELEMENTARY)

1. The sequence of instruction in this lesson and the next (component parts) will vary from that already met with. Demonstration will not be *complete*, but will be in phases giving full details. Each phase will be followed immediately by execution before demonstration of the next phase is given. In *Stage II* men will not be practised in complete stripping and assembling. The instructor will interrogate only on what has been done.

2. Preliminaries:—

- i. Stores required.—D.P. gun, magazines, spare parts, dummies, ground sheets.
- ii. Inspect gun and dummies.

3. *Sequence of instruction*.—Instructor states object of lesson: How to strip the main parts of the gun which require cleaning or changing, and how to do so without damaging them. For detail of description of parts see Appendix I.

Stage I. The body group

4. *Sequence of instruction*.

- i. The instructor demonstrates and explains how to strip and assemble each part in the sequence given below. Having stripped a part, he will briefly describe it. Parts when stripped will be put in a clean place and in methodical order. Each part will be removed and replaced by

each man. A different man will be selected as the first to remove successive parts.

(a) *Butt*.—With the *cocking handle* in the forward position insert the point of a bullet behind the *No. 1 catch* and press it upwards to disengage the catch. With the *No. 2 catch* press the *thumb piece* forward. Then rotate the *butt* one-eighth of a turn, underside of the *butt* to the right, and withdraw it.

To assemble.—Hold the *butt* with the underside at the same angle as when it was removed, place the *projections* on the *butt cap* into the guides at the rear end of the *body* and turn the *butt*.

(b) *Body cover*.—See that the *feed arm* is over to the right. Draw back the *body cover* until it is clear of its *retaining ledges* on the *body*. Lift off the *body cover*.

To assemble.—Place the *projections* on the *body cover* in the intervals between the *retaining ledges* on the *body* and slide the *body cover* forward.

(c) *Feed arm*.—With the point of a bullet press forward the *latch*. Turn the *feed arm* until the *key way* in the *axis hole* clears the *key* on the *magazine post*. Lift off the *feed arm*.

To assemble.—Place the *key way* over the *key* on the *magazine post* and turn the

feed arm to the left until the *groove* under the *tail* is resting on the *boss* on the *feed arm actuating stud*. With the point of a bullet press the *latch* back into its seating.

(d) *Pinion casing*.—Press the *trigger* in order to disengage the *scar nose* and *plunger* from their holes in the bottom of the *body*. Slide the *pistol grip* back, but do not withdraw it completely. Unhook the *pinion casing*.

To assemble.—Hook the *pinion casing* on to the *body*, see that the *cocking handle* is forward, raise the *pinion* and slide the *pistol grip* forward.

(e) *Cocking handle, bolt and piston rod*.—Draw back the *cocking handle* to its full extent and withdraw it from the *piston rod* by pulling it outwards. Draw out the *bolt* and *piston rod*.

To assemble.—Place the *piston rod* in the lower groove in the *body*. If obstruction is met with, see that the *scar* does not protrude into the *body*. Place the *bolt* on to the *striker post*. See that it is fully forward and that the *actuating stud* is screwed right up. Guide the *bolt* into the *bolt way*, pushing the *bolt* and not the *piston rod*. Insert the *cocking handle* into the recess in the *piston rod*, draw back the *cocking*

handle as far as possible and press it fully home before pushing right forward.

If obstruction is met with when replacing *bolt*, see that the *tail* of the *ejector* is not out into the *bolt* way. If the *feed arm* is on the gun, see that it is over to the left.

- (f) *Pistol grip, body locking pin and body.*—Withdraw the *pistol grip*. With the point of a bullet press back the *body locking pin*. Unscrew the *body* from the *barrel*. If the *body* is so tightly breeched up that it cannot be turned by hand, its removal will be undertaken only by an armorer.

To assemble.—Screw the *body* on to the *barrel*: with the point of a bullet, push the *body locking pin* forward. To replace the *pistol grip*, press the *trigger*, place the *guide grooves* on to the *guides* on the *body* and push slightly forward.

When it is not found possible to screw the *body* home to position by hand, it should be assembled only by the armorer, who will use his raw-hide mallet and strike the *body* on the right side near the bottom joint of the *locking piece*.

After the "body" has been removed from the "barrel" great care must be taken to preserve

the projections on the barrel from damage. The "barrel," and "radiator" should never be placed "muzzle" upwards on any hard surface.

- ii. Instructor then reassembles parts in exact reverse order.
- iii. Each man in the squad practised in stripping and reassembling the body group.

Stage II. The barrel group

3. Sequence of instruction.

- i. Instructor demonstrates and explains as in para. 4, i, above.

(a) *Clamp ring and front radiator casing.*—

Using spare *gas regulator key* unscrew the No. 1 *clamp ring screw* and remove the *clamp ring* and *front radiator casing*. The No. 2 screw will only be unscrewed so far that the screw is flush with the outside of the left wing of the *clamp ring*.

To assemble.—Replace the *clamp ring*, with the head of the screw to the right and the *positioning stud* in its seating in the *rear radiator casing*. Place the *front radiator casing* on the recess over the *positioning stud* on the *clamp ring*; then tighten the *clamp ring screw*.

- (b) *Field mount.*—This may be removed either muzzle or breech end, whichever is found easier. Unscrew the *band* and withdraw. If withdrawn forward—

turn it so that the opening passes the *gas regulator*.

To assemble.—When replacing see that the opening passes the *gas regulator*; then turn the *mounting* until the *clamping screw* is on the right. Before tightening the *wing nut*, see that the *band* is in the centre of the *gas regulator key* and that the *sights* are upright.

- (c) *Gas regulator and key.*—With the point of a bullet lift the *key* until the *stud* on its end is clear of the hole in the *radiator casing*. Remove the *key* and unscrew the *gas regulator*.

To assemble.—Screw the *gas regulator* into the *gas chamber*, replace the *key*, turn the *small hole* of the *regulator* to the rear. Then, with the point of a bullet, place the *stud* on the *key* into its seating in the *rear radiator casing*.

- (d) *Rear radiator casing.*—Slide the *casing* off to the rear.

To assemble.—See that the hole for the *gas regulator* is in line with the *gas chamber* and slide the *casing* on from the rear. Use the *piston rod* if necessary to seat the *gas cylinder* correctly into the *casing*. Great care must be taken to avoid damaging the *projections* on the rear face of the *barrel*.

- (e) *Gas cylinder.*—Insert the *piston rod* until about half of the rack has entered the *cylinder*. Then using the *piston rod* as a wrench, unscrew the *gas cylinder*. Take care not to use such force as would fracture the rear end of the *gas cylinder*.

To assemble.—Screw on to the *gas chamber*. See that the flattened portion is in correct alignment for replacing into the *rear radiator casing*. Care must be taken to see that the threads are not crossed.

- (f) *Gas chamber.*—Using the spanner, unscrew the *gas chamber*.

To assemble.—Screw into the *barrel band*, using the spanner to tighten. See that the *rear face* is in correct alignment to receive the *gas cylinder*. Care must be taken to see that the threads are not crossed.

- (g) *Barrel mouthpiece.*—Using the spanner, unscrew the *barrel mouthpiece*. This has a left-handed thread and must be turned as when screwing up an ordinary screw. When a *flash eliminator* is fitted, the *projections* on the *locking collar* which engage with the eliminator must be pressed upwards before the *eliminator* can be unscrewed.

To assemble.—Screw on to the *barrel*, using the spanner to tighten. Turn as when unscrewing an ordinary screw. Care must be taken to see that the threads are not crossed.

- ii. Instructor reassembles gun in exact reverse order
- iii. Instructor questions squad.

7. *Stripping and assembling (component parts)*

LESSON 5.—STRIPPING AND ASSEMBLING

(Component Parts)

(For sequence, see Lesson 4 (Sec. 6, 1))

1. *Preliminaries.*—As in Lesson 4.
2. *Sequence of instruction.*
 - i. Instructor states object of lesson :—To teach a man and, where applicable, an instructor how to strip the parts that may require changing or cleaning without causing damage or delay.
 - ii. Instructor demonstrates and explains the stripping and assembling of each of the component parts of the body group. As he strips each part he explains how it is done and whether it is a part which a man is allowed to strip. He then demonstrates how to put it back. Squad, according to its category, practises removing and replacing each part. The following com-

ponent parts of the body group will be stripped only as shown below :—

<i>By the man</i>	<i>By instructor</i>	<i>By armorer</i>
Cartridge guide.	Pinion pawl.	Butt cap.
Magazine stop pawls.	Trigger and	Tangent sight.
Feed arm pawl and	sear.	Striker.
spring.		Butt catch and
Body group less		spring.
pinion pawl.		
Extractor.		
Ejector.		

A squad of recruits practises only column 1.

“ “ N.C.Os. “ columns 1 and 2.

Component parts :—

- (a) *Cartridge guide.*—With the point of a bullet press the *stud* down and to the right; with the forefinger and thumb withdraw the *cartridge guide*.

To assemble.—Hold the hinged portion and slide back into its seating until the *stud* springs into the hole in the tongue.

- (b) *Magazine stop pawls.*—Place the hand over the *pawls* and, with the point of a bullet, force the *stud* on the *pawls* spring out of its seating; lift the *pawls* off their *studs*.

To assemble.—Place the *pawl* marked “ 1 ” on the *stud* marked “ 1,” and the No. 2 *pawl* on the No. 2 *stud*. Hold

the *spring* with the *lip* uppermost, and place it in rear of the *pawls*; press down until the *stud* springs into its seating.

- (c) *Feed arm pawl and spring*.—Hold between the forefinger and thumb; press the *pawl* back towards the *spring*; lift *pawl* and *spring* off their *studs*. Remove the *spring* from the *pawl*.

To assemble.—Replace the *spring* on the *pawl*; hold *pawl* and *spring* as when stripping; press the *pawl* back; place end of *spring* and *axis hole* of *pawl* on their *studs* on the *feed arm* and press down. See that the *pawl* rests behind the *stop stud* on the *feed arm*.

- (d) *Pinion group less pinion pawl*.—Raise the *pinion pawl*. This will take the tension off the *return spring* and release the *tension screw* from its seating in the *pinion casing*. If there is insufficient tension on the *spring* to release the *tension screw*, keep the *pinion pawl* raised and turn the *pinion* by hand. Remove the *tension screw*; take the *pinion* out of its *casing*; place the point of a bullet in the *centre hub* and force the *spring casing* out of the *pinion*; remove the *centre hub*.

To assemble.—Place the *centre hub* on the

lip of the *spring* and in its seating in the *spring casing*; place the projection on the *spring casing* into the recess inside the *pinion* and press home. Place the *pinion* into the *pinion casing* and screw in the *tension screw*. To get the head of the *tension screw* back into its seating the *pinion* must be turned by hand.

- (e) *Extractor*.—Place the point of a bullet under the *claw* and push outwards from the *bolt* until the *stud* under the *extractor* is clear of its seating. Using the bullet as a lever draw the *extractor* out. Take care not to strain the *extractor* by pushing it outwards more than is necessary. The *Mark II extractor* is removed in a similar manner, the *spring* being subsequently removed by pressing the point of a bullet between the end of the *slot* in the *bolt* and the *groove* in the end of *spring*, and then withdrawing the latter.

To assemble.—Place the *shoulders* on the *shank* of the *extractor* into their *guides* on the *bolt*, and force the *extractor* back into position by pressing it firmly against some article which will not damage the *claw*.

- (f) *Ejector*.—Place the point of a bullet in the hole in the *ejector cover*, raise the

cover and slide it to the rear. Place the point of the bullet through the hole on the left underside of the body and push the stud of the ejectors out of its seating. Lift the ejector out.

To assemble.—Place the stud into its seating and replace the cover. It is very important that the cover is pushed right home.

Note.—When changing an ejector with the piston rod and bolt in the gun, it may be necessary to pull the cocking handle half way back. This prevents the bolt from causing obstruction when replacing the ejector.

(g) *Pinion pawl and spring.*—Remove the pinion as already taught. With a punch, knock out the pinion pawl axis pin and remove the pawl and spring.

To remove the spring from the pawl, lift first one end from the hole in the pawl and then the other end. This prevents straining the spring.

To assemble.—Replace the spring on the pawl, hold the pawl and spring in position in the pinion casing, the arm of the pawl with the lip being inside the casing with the spring behind it. Replace the axis pin. See that the pin is flush with the sides of the casing, otherwise the pinion casing cannot be raised into position on the gun.

(h) *Trigger and sear.*—With a punch, knock out the sear axis pin and remove the sear. Place one hand over the plunger to prevent losing plunger or spring, knock out the trigger axis pin, draw the trigger back clear of the plunger and the shoulders on the trigger guard, remove trigger, plunger and spring.

To assemble.—Place the spring and plunger in position in the trigger guard and compress the spring by pressing the plunger down. Place the trigger inside the guard and slide it forward until the front arm engages the recess in the plunger. Replace the axis pin. Place the front end of the sear in the knuckle joint of the trigger and replace the axis pin. See that both axis pins are flush with the sides of the guard, otherwise the guard cannot be replaced on the body of the gun.

iii. After all components have been dealt with, instructor practises the squad in removing various parts with a minimum amount of stripping.

Changing parts with a minimum amount of stripping.

<i>Parts to be changed.</i>	<i>Amount of stripping necessary.</i>
1. Cartridge guide ...	Cartridge guide only.
2. Feed arm pawl or spring ...	Butt and body cover.

<i>Parts to be changed.</i>	<i>Amount of stripping necessary.</i>
3. Right or left stop pawl or spring ...	Butt and body cover.
4. Bolt	Butt—withdraw pistol grip slightly—remove cocking handle.
5. Piston	As for bolt.
6. Ejector	Butt and body cover. It may be necessary to withdraw pistol grip slightly and pull cocking handle half way back.
7. Pinion group. ...	Butt—withdraw pistol grip slightly.

8. Care and cleaning

LESSON 6.—CARE AND CLEANING

1. Preliminaries.

Stores required.—Gun, magazines, spare parts and holdall. Ground sheets.

2. Sequence of instruction.

- i. Instructor states that the efficient working of the gun depends on the cleanliness of the parts and the care taken to see that they are in proper working order. This lesson will show the methods of cleaning the parts and the occasion when such methods are used. There are five different types of cleaning :—

- (a) Daily,
- (b) Before firing,

(c) After firing.

(d) Complete.

(e) After gas attack.

When any part is being cleaned it will be carefully examined for any wear or tear.

Daily cleaning.

- ii. Instructor demonstrates, giving detail as follows :—

(a) Strip the gun down to the *body locking pin*.

(b) Briefly describe *barrel cleaning rod*.

(c) Clean and re-oil *barrel*, bringing out use of *cleaning rod* as follows :—

Place a piece of flannelette, about 4" by 1½", in the *eye* of the *cleaning rod*, taking care to surround the metal of the *cleaning rod* with the flannelette, which must be well oiled. Insert the *rod* into the *muzzle* and pass it up and down the *bore* until all fouling has been removed. Then dry the *bore* and re-oil.

For oiling, the size of the flannelette will be slightly smaller than 4" by 1½". If the flannelette is pushed right through the barrel, it must be reversed before being pulled back, otherwise it will jam.

(d) Dry clean and slightly oil all parts, except gas-affected parts in the barrel group.

iii. Instructor explains variation of daily cleaning according to circumstances :—

(a) If the gun has been used for drill purposes or has become dusty or wet, it will be necessary to clean as laid down above.

(b) If the gun is clean and kept in a gun chest, all that is necessary is to cock the gun, use the *barrel cleaning rod* as before, re-oil the *barrel* and take care to leave the *cocking handle* in forward position, the outer surfaces to be wiped over with a piece of oily flannelette.

iv. Instructor questions squad on actions performed and gives reasons for them, compared with methods of cleaning a rifle.

Size of flannelette 4" by 1½"—smaller than rifle owing to size of rod.

Flannelette wrapped round metal of the *rod* to prevent scratching of the *barrel*.

From *muzzle* to *breech*—to prevent damage to the *lip of the barrel*.

v. Squad practises.

Before firing.

vi. The gun will be cleaned as for daily cleaning, except that the *barrel* will be left perfectly dry.

After firing.

vii. The instructor refers to the foulings which occur in the rifle after firing and explains that he is going to teach how these should be dealt with

in the case of the light automatic. Metallic fouling, as in the rifle, will be removed only by an armourer.

viii. The instructor has the *body group* stripped by the squad. He then makes one of the squad remove the superficial fouling as already taught, using the *barrel cleaning rod*.

(a) *Removal of hard fouling from the barrel.*—

Instructor describes the *double pull-through and gauze*, and demonstrates its use with the assistance of two of the squad.

Thoroughly oil the gauze on the pull-through and drop the *weight* through the *bore* from the *breech*.

Ensure that the *barrel* is held horizontally by one man. With the assistance of the other pull the cord backwards and forwards in line with the axis of the *bore* until the fouling is loosened.

The *barrel* will now be cleaned with the cleaning rod and flannelette as already described, leaving well oiled.

When to clean the *barrel*.—When ball ammunition has been fired, special care of the *barrel* is necessary for at least ten days afterwards. Subsequent cleaning must depend on the discretion of the officer responsible.

(b) *Cleaning of chamber.*—If the *chamber* has not been properly cleaned by the above process, place a larger piece of flannelette in the *eye* of the *cleaning rod*, insert the rod from the *breech* end and clean the *chamber*, first with oiled and then with dry flannelette, then re-oil.

(c) *Cleaning of cylinder.*—Join up the *cylinder cleaning rod* and screw on to it the *wire brush* well oiled. Insert the rod and work it backwards and forwards a few times. Then remove the *wire brush*, replace it with the *mop*, which will be covered with a piece of flannelette, and re-oil, using *barrel cleaning rod* with a piece of flannelette 4" by 4". Care should be taken that the extreme front end of the *cylinder* is reached by the brush and thoroughly cleaned, for it is at this point that the fouling collects most thickly.

ix. Instructor questions squad on actions performed, as stated in sub-para. viii, above, and gives reasons for certain items as follows:—

- (a) Need for two men when using double pull-through as a precaution against cord wear.
- (c) Wire brush oiled to prevent scratching of the cylinder.
- (c) Fouling collects most thickly at extreme front end of cylinder.
- (c) Use of flannelette to preserve the mop

- x. Squad practised on cleaning after firing. The gun is then reassembled.

Temporary cleaning after firing.

- xi. Instructor explains that, when cleaning after firing cannot be carried out immediately, the following temporary method of cleaning will prevent the fouling from getting hard. This is likely to be used frequently on service.
- xii. Instructor has the *butt*, *bolt* and *piston rod* removed. Clean the *barrel* with the *rod*, and oil. Oil the following parts:—
 - (a) Gas cylinder, using barrel cleaning rod and 4" by 4" flannelette.
 - (b) Head of the piston rod.
 - (c) Face of the bolt.
 - (d) Barrel mouthpiece.
 - (e) Fore radiator casing.

Complete cleaning.

- xiii. Instructor explains that periodically the gun requires to be completely stripped and cleaned. Excessive stripping, especially of the *cylinder*, *gas regulator*, *chamber* and *barrel mouthpiece* causes wear, therefore complete cleaning will only be done when considered essential by the platoon commander. Whenever available, boiling water will be used for cleaning the barrel and gas affected parts.
- xiv. Instructor has the *body* and *barrel groups* stripped down by two of the squad. He

explains that the method of cleaning the barrel and gas cylinder without using boiling water has already been taught. If the *cylinder* is found to be a very tight fit on the *gas chamber*, no attempt should be made to force it, but the joint should be first saturated with mineral burning oil (paraffin) for a time to loosen the rust. On no account should emery be employed to clean the *cylinder*, as this would enlarge the *bore* and so cause an excessive leakage of gas beyond the *piston head*. Great care must be taken not to cross the threads when replacing the *cylinder*.

He then demonstrates cleaning the *gas chamber* and *regulator* with the *cleaner gas regulator*, pointing out where the fouling collects and how it should be removed:—

- (a) Place all gas affected parts in boiling water.
- (b) Remove from boiling water and dry.
- (c) Apply oil to regulator to loosen fouling.
- (d) Remove fouling with cleaner.
- (e) Dry clean and re-oil.

xv. Instructor reasons with squad by question and answer the cleaning of the *barrel*, *gas cylinder*, *chamber*, *regulator* and *barrel mouthpiece*, comparing with rifle where applicable. He emphasizes need for special care being taken to prevent damage to the threaded end of the cylinder both when cleaning and reassembling.

xvi. Instructor distributes various parts amongst the squad who practise cleaning them, after which the gun will be reassembled.

Cleaning of magazines and spare parts, and general notes on cleaning.

xvii. Instructor brings out by question and answer, where possible, the points given below:—

(a) *Magazine.*

All dirt and grit removed.

Left slightly oiled.

For firing will be thoroughly dried, but *magazine catch* to be slightly oiled.

(b) *Spare parts in the holdall.*

Frequently inspected.

Kept in correct pockets.

Slightly oiled condition.

(c) *General.*—When a screw thread is found to have seized or to fit very tight no attempt should be made to force. The joint should be thoroughly soaked in paraffin to loosen it.

Paraffin is a convenient means of loosening and removing rust, but if left in contact with steel it assists the formation of rust. After use, therefore, it must be carefully removed and the part oiled with G.S. lubricating oil * which, in addition to being a lubricant, is also a

* Now designated "oil, lubricating, M/80" for demanding purposes.

preservative. The use of emery or other cutting or gritty substance is strictly forbidden.

To clean the mechanism a mixture of equal parts of G.S. oil and mineral burning oil (paraffin) should be used. If any parts are clogged with dried oil, paraffin should be used to remove it. After cleaning each part it should be thoroughly dried and slightly oiled with G.S. oil. Very little oil should be used for this purpose, as it is apt to catch the dust and clog.

After gas attack.

- xviii. The instructions contained in Vol. I, 1931, Sec. 23, "Protection of weapons and equipment from gas," apply to the light automatic. The instructor will ensure that the recruit does not confuse the gas which operates the gun with mustard and poisonous gases. He will bring out the means of protecting the light automatic from such gases by means of question and answer with reference to the protection of the rifle.

9. Elementary mechanism : backward and forward action

LESSON 7.—ELEMENTARY MECHANISM; BACKWARD AND FORWARD ACTION

1. Preliminaries.

- i. Stores required.—D.P. gun, spare parts, and ground sheets.

- ii. Arrange skeleton action by assembling the following parts:—*Body, bolt and piston rod, pistol grip, pinion, feed arm and butt.*
- iii. Have the following spares laid out ready:—*Piston rod, pinion and bolt.*

2. Sequence of instruction.

- i. Instructor states that object of the lesson is to teach the general mechanism by which the gun works, known as backward and forward action, and the forces which operate the gun.

Backward action (demonstration with question and answer).

- ii. *Action of gases.*—When a round is fired, gases force the bullet up the *barrel*. When it has passed the *gas vent* in the *barrel* a portion of the gases passes through the *vent* into the *gas chamber* and *regulator*, and thence through holes on to the head of the *piston rod*, forcing it back.

- iii. *Action of the piston rod.*—(Instructor using spare *piston rod, pinion* and *bolt* as required.)

(a) *On the return spring.*—The *rack* on the *piston rod* rotates the *pinion* and so winds the *return spring*.

(b) *On the bolt.*—The right side of the *striker post* working against the right side of the *cam slot* in the *bolt* rotates the *bolt* to the left. The *locking lugs* are now clear of their *recesses* in the *body* and in line with the *guide*

grooves. The rear of the *striker post* then comes against the rear end of the *slot* and carries back the *bolt*.

Instructor now briefly explains that during the backward action of the *bolt* the empty case is extracted and ejected.

iv. *Action of the bolt on the feed arm.*—The *feed arm actuating stud* working in the groove in the underside of the *feed arm* carries the latter over to the left. This action will load the gun.

v. Instructor questions squad on the whole of the backward action.

Forward action (demonstration with question and answer).

vi. *Action of return spring on piston rod.*—Instructor using spare *piston rod* and *pinion* shows how the *return spring* unwinding rotates the *pinion*. This forces the *piston rod* forward.

vii. *Action of piston rod on the bolt.*—Instructor, using spare *piston rod* and *bolt*, shows that, owing to the *locking lugs* being in their *guide grooves*, the left side of the *striker post* bearing against the left side of the *cam slot* in the *bolt* carries the *bolt* forward. When the *locking lugs* are opposite their *recesses* in the *body*, the left side of the *striker post* bearing against the left side of the *cam slot* rotates the *bolt* to the right. The *lugs* are now in their *recesses* in the *body* and the *bolt* is locked.

[To face page 48

PLATE 3

GUN ASSEMBLED FOR TEACHING
"Backward and Forward Action"



Instructor now briefly explains that during the forward action of the *bolt* the round will be taken into the chamber.

viii. *Action of the bolt on the feed arm.*—The *feed arm actuating stud* working in the *groove* in the underside of the *feed arm* carries the latter over to the right.

ix. *Action of the striker.*—Instructor, using spare *piston rod* and *bolt*, shows how after the bolt has been locked the *striker* passes through the hole in the *face of the bolt* and fires the round, again starting backward action.

x. Instructor questions squad on :—

(a) Forward action.

(b) Backward and forward action.

Action of the trigger and sear (demonstration by question and answer).

xi. Instructor using skeleton action assembled shows how the automatic action is controlled by the pressing and releasing of the *trigger*.

xii. Instructor using *pistol grip* teaches what happens on pressing and releasing the *trigger* :—

On pressing the *trigger* the forward arm of the *trigger* being engaged in the *recess* in the *plunger*, depresses the latter causing the *trigger spring* to become compressed. The *knuckle joint* on the rear arm of the *trigger* being engaged with the front-end of the *sear* lifts the latter and causes the nose of the *sear* to be depressed.

xiii. On releasing the *trigger* the *trigger spring* forces the *plunger* up, thereby lifting the *front arm* of the *trigger* and lowering the *rear arm*. The *knuckle joint* pulls down the front end of the *sear*, causing the *nose of the sear* to rise.

xiv. Instructor using the *body* and *pistol grip* shows how on pressing the *trigger* the *nose of the sear* is brought clear of the *piston way* in the *body*. On releasing the *trigger*, the *sear* rises through the *recess* into the *piston way*, but the *plunger* does not protrude.

xv. Instructor using spare *piston rod* and *pistol grip* shows that when the *trigger* is released the parts will always stop in the rear position provided there are rounds in the magazine. During the backward action the bevelled portion on the rear end of the *piston* bears on the bevelled portion of the *sear* and depresses it. This compresses the *trigger spring*. When the *bent* on the *piston* is clear of the *sear* the *trigger spring* causes the *sear* to rise and engage in the *bent*.

xvi. Instructor questions squad on the action of the *trigger* and *sear*.

The pinion group (demonstration with question and answer).

xvii. *Action of the return spring*.—Instructor using the spare *pinion* stripped down explains that the *return spring* is wound as follows:—

The spring is contained in a *casing* to which

the outer end is secured. The other end of the spring fits into the central hub.

The *spring casing* when assembled within the *pinion* must rotate with it owing to a projection on the former fitting into a shallow recess within the *pinion*.

When the *pinion* is assembled within the *pinion casing* the *hub* is held stationary by means of the *tension screw*, the head of which is prevented from turning by two projections on the outside of the *pinion casing*.

When the *pinion* is rotated during the backward action the *return spring* is wound round the *central hub*.

When the *return spring* is allowed to unwind, it rotates the *pinion* in an opposite direction, thus forcing the *piston rod* forward.

xviii. *Action of the pinion pawl and spring* (instructor using pistol grip and pinion).—The *rib* on the downward arm of the *pinion pawl* engages with the *pinion* and prevents the *spring* unwinding when the *pinion* is not engaged with the *rack*, e.g. when the *casing* is disconnected for the purpose of adjusting tension on the *spring* or for stripping.

The horizontal arm of the *pawl* which projects from the *casing* is lifted by the front end of the *trigger guard* as the latter is assembled, thus compressing the *pinion pawl spring* and removing the *rib* of the *pawl* from the *pinion*. In this way it leaves the *pinion* and *return spring* controlled by the *rack*.

10. *Points before, during and after firing*

LESSON 8.—POINTS BEFORE, DURING AND AFTER FIRING

1. *Preliminaries.*

Stores required.—Gun, magazines, dummies, spare parts, and ground sheets.

2. *Sequence of instruction.*

- i. Instructor states that the light automatic being a mechanical weapon is liable to stop firing owing to some small defect or breakage in the mechanism. Many of these will never occur if proper attention is given to "Points before, during and after firing."

Before firing.

- ii. The instructor has the gun stripped and cleaned as taught in Lesson 6, and reassembled by the squad.
- iii. Demonstrates and explains how to test, increase, or decrease weight of the *return spring* :—

(a) *How to test weight* :—

The weight required on the *return spring* varies from about 13 to about 15 pounds. No two guns behave in exactly the same way, and accurate balancing of the *return spring* is of the utmost importance. The exact amount of weight required by any particular gun can only be found by experience. Inaccurate balancing will

make holding more difficult and will increase the number of stoppages.

Instructor gives brief description of the *spring balance*, pointing out the graduations and figures representing pounds of weight, and the loops.

Place one loop over the outer end of the *cocking handle* and the forefinger through the other loop. Pull back the balance on the same alignment as that along which the *cocking handle* moves. Read the weight shown on the *spring balance* at the first movement of the *cocking handle*.

(b) *How to increase weight* :—

Remove the *butt* and draw the *pistol grip* back sufficiently far to disengage it from the *pinion casing*.

Press up the *pinion casing* with the left hand to keep the *pinion* in engagement with the *rack*, and draw back the *cocking handle*. For each inch the *cocking handle* is drawn back the tension will be increased by approximately three pounds. It is not advisable to draw the *cocking handle* back more than two inches at a time.

When the *cocking handle* has been drawn back, allow the *pinion casing* to drop so that the *pinion* is out of engagement with the *rack*.

Push the *cocking handle* forward and raise the *pinion casing*. Repeat these

actions until it is judged that the required weight is on. With the *cocking handle* forward slide the *pistol grip* forward and test for weight. When the exact weight required is shown on the *spring balance* replace the *butt*.

(c) *How to decrease weight* :—

Remove the *butt* and draw the *pistol grip* back sufficiently far to disengage it from the *pinion casing*.

Allow the *pinion casing* to fall so that the *pinion* is not engaged with the *rack*, and draw back the *cocking handle*.

When the *cocking handle* has been drawn back to such a distance as will give the required decrease of tension, press up the *pinion casing* with the left hand to engage the *pinion* with the *rack*, and slide forward the *pistol grip*. This action will cause the *cocking handle* to fly forward. When the exact weight required is shown on the *spring balance* replace the *butt*.

(d) *Spare return spring* :—

Instructor will explain that the spring must always be tested and adjusted to the correct weight before firing. During execution of (a), (b) and (c) men will be made to use both springs. When not in use weight of spring will be reduced to about four pounds.

- iv. Instructor questions squad on (a), (b) and (c) of above.
- v. Each man practises balancing the gun to the exact firing weight named by the instructor and decreasing that weight.
- vi. Instructor gives condition of test (Sec. 20).

Examination of gun.

- vii. Instructor working from front to rear of the gun demonstrates the careful examination of the following parts, naming each in turn :—*Barrel mouthpiece, clamp ring and screw, foresight, gas regulator and key, field mount, trying weight* by moving the *cocking handle, feed arm pawl and spring, stop pawls, and backsight*.
- viii. Instructor questions squad and gives reasons for examination of various parts :—
 - (a) *Barrel mouthpiece* tightly screwed up.
 - (b) *Clamp ring screw* tight and head of the screw to the right.
 - (c) *Foresight* undamaged.
 - (d) *Gas regulator* and key correctly assembled and small hole of the *regulator* to the rear.
 - (e) *Field mount* ; *band clamping screw* on the right ; *leg clamping screws* tight.
 - (f) Try weight on *return spring* to ensure that the firing weight has not been taken off.
 - (g) *Pawls, springs* and *backsights* undamaged.
- ix. Squad practises.

Magazines.

- x. Instructor has *magazines* cleaned, examined and filled by the squad.
- xi. When training N.C.O.s, instructor will mention *magazine testing gauge*, which is part of the armourer's equipment. Magazines should be tested by the armourer prior to the annual course.

Spare parts.

- xii. Instructor teaches *contents of holdall* and has *spare parts* checked and cleaned. Squad will be questioned as to the respective positions, on the gun, of the various spare parts.

Points during intervals of firing.

- xiii. Instructor brings out the following procedure, demonstrating where necessary :—
 - (a) Clear gun (already taught).
 - (b) Examine *clamp ring screw* and tighten if loose.
 - (c) Oil working parts through ejection and feed openings.
 - (d) If the balancing of the *gas* and *spring* has been found unsatisfactory, add or take off weight as necessary. In any case the weight of the return spring should be tested.
 - (e) If the *bolt* or *pinion group* has been replaced during firing with a spare,

No. 2 will replace the damaged extractor or return spring from the holdall.

- xiv. Instructor questions squad on points given in sub-para. xiii, above, and gives reasons for certain items as follows :—
 - (b) Accurate shooting cannot be obtained if the *clamp ring screw* is loose.
 - (c) To prevent friction and stoppages resulting from it. In cold weather the amount of oil used for lubrication should be reduced to a minimum, as it is likely to congeal, and affect the working of the mechanism.
 - (d) Inaccurate balance affects accuracy of shooting and causes stoppages due to faults in feeding.
 - (e) To ensure that a spare *bolt* and *pinion group* is ready.

- xv. Squad practises at discretion of instructor.

Points after firing.

- xvi. Instructor performs the following :—
 - (a) Clear gun (already taught).
 - (b) Clean the gun as for "After firing," Lesson 6.
 - (c) Check spare parts, replace breakages and deficiencies.
 - (d) Reduce weight on return springs.
 - (e) Instructor teaches how to pack the gun in the chest. (See Appendix II.)

STOPPAGES

58

11. Immediate action

NOTES FOR INSTRUCTORS

- i. When giving the second or "quick" demonstration one of the squad will be made to act as "No. 2." A different man should be used for each stoppage.
- ii. Practising the squad by words of command without setting up the stoppage will be introduced as soon as each man in the squad can apply the correct "Immediate Action" (I.A.) when the stoppage has been set up.
- iii. The methods of setting up each stoppage and the words of command are given in the following table:—

Position of cocking handle	Name and cause of stoppage	How to set up	Words of command for handling exercises	Setting up for stoppage practices on the range
(1) 1st	(2) Empty magazine.	(3) Load with magazine containing one round and, having fired, state "Gun stops."	Nil. (4) Occurs automatically.	(5) Not to be set up. Will occur automatically.
1st	Missfire.	Load with full magazine and, having fired, state "Gun stops."	Words of command. "Gun is firing all right." "Gun stops." "Firing all right."	Load magazine with a few live rounds, one dummy, then a few live rounds.

[Chap. I, Sec. 11.]

1st

Damaged magazine.

(i) Load with full magazine. Give words of command for a "Missfire," and when I.A. has been performed state "Won't fire."
(ii) When setting up in Lesson 11 use a damaged magazine. To fill a damaged magazine see that the lip of the centre block is to the left of the damaged part and fill up to the damage. Try it on the gun to see that it does not feed.

Words of command. "Gun is firing all right."
"Gun stops."
"Won't fire."
"Firing all right."

Load magazine with a few live rounds, two dummies, then a live round.

2nd

Hard extraction.

Load with full magazine and, having fired (with the gun in the shoulder), pull cocking handle back far enough to extract and eject the empty case, then ease it forward when it will stop in the 2nd Position. State "Gun stops."

Words of command. "Gun is firing all right."
"Stops 2nd."
"Firing all right."

Load magazine with a few live rounds, one dummy, then a few live rounds. When gun stops on dummy state, "Flange off the trigger, head away." Then position cocking handle in 2nd position stating "Carry on firing."

Chap. I, Sec. 11.]

59

Position of cocking handle	Name and cause of stoppage	How to set up	Words of command for handling exercises	Setting up for stoppage practices on the range
— (1) 3rd	<p>(2) Double Feed (1st Phase). Cause:— Worn or damaged magazine.</p>	<p>(3) For Instructor's demonstration:— Load with full magazine and, having fired (with the gun in the shoulder), pull cocking handle right back, and, with the little finger, press the trigger, then ease the cocking handle forward when it will stop in the 3rd Position. State "Gun stops." (ii) When the squad practises state:— "Gun is firing all right." "Finger off trigger, head away." Cock the gun, depress R.S. pawl, using handle of an aiming disc or other suitable instrument, and force magazine round as far as possible, hold magazine with left hand, position cocking handle with right, tell man to carry on firing, and state "Gun stops." Remove hand when man counter-rotates.</p>	<p>(4) Words of command. "Gun is firing all right." "Stops 3rd." "Magazine counter-rotates." "Gun is firing all right." "Fires 4 or 5 bursts and stops again 3rd." "Magazine counter rotates." "Gun is firing all right."</p>	<p>(5) Will not be set up.</p>

2nd followed by 3rd.

Double Feed (2nd Phase).

Cause:—
Worn or damaged magazine.

Load with full magazine and, having fired (with the gun in the shoulder), pull cocking handle right back, and, with the little finger, press the trigger, push cocking handle forward far enough to knock the round into the chamber, then put the cocking handle into the 2nd Position and state "Gun stops." Apply I.A. and state "Was't fire."
(The cocking handle will now be in the 3rd Position.)

Words of command. "Gun is firing all right." "Stops 2nd." "Will not fire 3rd." "Gun is firing all right." or "Fires 4 or 5 bursts and stops 2nd." "Will not fire 3rd." "Firing all right."

Note:— These two phases of a double feed may also be given in the following way:—
"Gun is firing all right." "Stops 3rd—magazine counter-rotates." "Fires 4 or 5 bursts and stops 2nd." "Will not fire 3rd." "Gun is firing all right." or vice versa.

Will not be set up.

LESSON 10.—IMMEDIATE ACTION

1. *Preliminaries.*

Stores required.—D.P. gun, magazines and dummies, spare parts, landscape target and ground sheets.

2. *Sequence of instruction.*

Instructor states scope and object of lesson.—

Experience has taught that the majority of stoppages which occur in the gun may be remedied by applying an action known as "*Immediate Action*." It is, therefore, necessary to practise the action until it becomes instinctive. By this means no time is wasted, particularly at a time when fire is most needed. Instructor will *explain* and *demonstrate*, with full magazine on, that the gun will stop in one of three positions. These positions will be shown to squad:—

i. With reference to the *trigger* :

1st position. Cocking handle forward, well in front of trigger.

2nd position. Cocking handle over the trigger.

3rd position. Cocking handle behind the trigger, but not far enough back to be fully cocked.

ii. With reference to *parts of hand* :

With the gun in the shoulder raise the right hand straight up from the pistol

grip, fingers extended and palm inwards :

1st position if cocking handle is felt near tips of fingers.

2nd base

3rd base of thumb.

Interrogation.—Instructor will set the three positions in varying order and question the squad on i. and ii. above.

1st Position

3. *Sequence of instruction.*i. *Empty magazine.*

Demonstration.—Bringing out action by question and answer.

(a) Load with magazine containing one round.

(b) Indicate target, aim and fire, state "**Gun is firing all right.**"

(c) Give command "**Gun stops.**"

(d) Feel for cocking handle, try to rotate magazine. If it rotates, call out "**Change,**" reload, aim and fire.

(e) State "**Gun is firing all right.**"

Quick demonstration.—Instructor now gives a quick demonstration to show the speed at which "*I.A.*" should be performed.

Interrogation.—Instructor questions the squad on the actions performed.

Execution.—Squad practises in pairs.

ii. *Missfire.*

Demonstration.—Bringing out action by question and answer.

- (a) Load with full magazine.
- (b) Indicate target, aim and fire, state "Gun is firing all right."
- (c) Give command "Gun stops."
- (d) Feel for cocking handle, try to rotate magazine; if magazine does not rotate, reload, aim and continue firing.
- (e) State "Gun is firing all right."

Quick demonstration.—Instructor now gives a quick demonstration.

Interrogation.—Instructor questions the squad on the actions performed.

Execution.—Squad practises in pairs.

iii. *Damaged magazine.*

Demonstration.—Bringing out action by question and answer.

- (a) Load with full magazine.
- (b) Indicate target, aim and fire, state "Gun is firing all right."
- (c) Give command "Gun stops."
- (d) Feel for cocking handle, try to rotate magazine; if magazine does not rotate, reload, aim and fire—when trigger has been pressed, state immediately "Gun won't fire."

- (e) Feel for cocking handle, and, if found in the 1st position, call out "Change," reload, aim and continue firing.

- (f) State "Gun is firing all right."

Quick demonstration.—Instructor now gives a quick demonstration.

Interrogation.—Instructor questions the squad on the actions performed.

Execution.—Squad practises in pairs.

2nd Position

4. *Sequence of instruction.*

Instructor states that, having taught the "Immediate Action" for 1st position stoppages, he will now teach the "I.A." for the 2nd position.

Hard extraction.

Demonstration.—Bringing out action by question and answer.

- (a) Load with full magazine.
- (b) Indicate target, aim and fire, state "Gun is firing all right."
- (c) Position cocking handle in the 2nd position and continue firing.
- (d) Give command "Gun stops."
- (e) Feel for cocking handle and, when found in the 2nd position, pull back, aim and continue firing.
- (f) State "Gun is firing all right."

Quick demonstration.—Instructor now gives a quick demonstration.

Interrogation.—Instructor questions the squad on the actions performed.

Execution.—

Squad practises in pairs.

Squad practises 1st and 2nd positions intermixed.

3rd Position

5. Sequence of instruction.

Instructor states that, having taught the "Immediate Action" for 1st and 2nd position stoppages, he will now teach the "I.A." for the 3rd position.

Double Feed (1st Phase).

Demonstration.—Bringing out action by question and answer.

- (a) Load with full magazine.
- (b) Indicate target, aim and fire, state "Gun is firing all right."
- (c) Position cocking handle in the 3rd position and continue firing.
- (d) Give command "Gun stops."
- (e) Feel for cocking handle and, when found in the 3rd position, pull back, try to counter-rotate the magazine. Whether it counter-rotates or not, aim and continue firing.
- (f) State "Gun is firing all right."

(g) Similar action if stoppage occurs after four or five bursts.

Quick demonstration.—Instructor now gives a quick demonstration.

Interrogation.—Instructor questions the squad on the actions performed.

Execution.—Squad practises in pairs.

2nd Position followed by 3rd Position

6. Sequence of instruction.

Double feed (2nd Phase).

Demonstration.—Bringing out action by question and answer.

- (a) Load with full magazine.
- (b) Indicate target, aim and fire, state "Gun is firing all right."
- (c) Set up 2nd Phase (i.e. live round in chamber and cocking handle in 2nd position) and continue firing.
- (d) Give command "Gun stops."
- (e) Feel for cocking handle and, finding it in the 2nd position, pull back, press the trigger and state immediately "Gun won't fire."
- (f) Feel for cocking handle and, finding it in the 3rd position, pull back, call out "Magazine off," clear top round over the top, taking care not to let the cocking handle go forward, re-cock, replace the same magazine and continue firing.

(g) State "Gun is firing all right."

(h) Similar action if stoppage occurs after four or five bursts.

Quick demonstration.—Instructor now gives a quick demonstration.

Interrogation.—Instructor questions the squad on the actions performed.

Execution.—

Squad practises in pairs.

Squad practises 1st, 2nd and 3rd positions intermixed.

Repetition.—

Squad practises in pairs, the "I.A." for all positions by words of command.

Instructor gives conditions of test (Sec. 20).

12. Mechanism of immediate action stoppages

LESSON 11.—REASONING THE CAUSES OF STOPPAGES CURED BY IMMEDIATE ACTION

1. Preliminaries.

Stores required.—D.P. gun; magazines (including one cut and one damaged), dummies, spare parts, landscape target and ground sheets.

2. Sequence of instruction.

i. Instructor states that the object of this lesson is to teach the causes of stoppages cured by "I.A."

ii. Two of the squad will be put through the "I.A." for the stoppage to be dealt with.

iii. Instructor reproduces the stoppage.

iv. Arrive at the cause by "Question and Answer," going by the most direct method.

v. Teach the mechanism concerned.

1st Position

(a) Empty magazine.

To reproduce for reasoning.—See that the chamber is empty and place an empty magazine on the gun.

Mechanism concerned (use a cut magazine).—Show that a magazine which contains rounds will not rotate owing to the round coming in contact with the cartridge stop on the feed arm.

(b) Missfire.

To reproduce for reasoning.—Load with a full magazine and press the trigger.

Mechanism concerned.—Nil.

(c) Damaged magazine (use a damaged magazine).

To reproduce for reasoning.—Replace the damaged magazine on the gun, pull back cocking handle and press the trigger. See that the chamber is empty.

Mechanism concerned.—Teach the action of the feed arm pawl and spring.

Remove the butt, body cover, and slightly withdraw the pistol grip.

- (i) With a good magazine show that during the backward action the feed arm pawl, being engaged behind a projection on the magazine, rotates the magazine in a feeding direction.
- (ii) Show that during the forward action the feed arm pawl rides over a projection on the magazine, thus compressing the feed arm pawl spring. When the pawl is clear of the projection, the spring forces it forward.

Instructor must hold the magazine stationary with the left hand when showing the forward action.

- (iii) With the damaged magazine, show how the feed arm pawl was unable to function.

2nd Position

(d) *Hard Extraction.*

To reproduce for reasoning.—Place a full magazine on the gun and position the cocking handle in the 2nd position.

Mechanism concerned (use a cut magazine).

- (i) Show correct feeding of the round from the magazine to the feedway. During the rotation of the magazine the

cartridge is carried to the left by the separating pegs and the indentations of the magazine, aided by the right side of the cartridge opening in the feed arm, until it reaches the cartridge opening in the body, by which time it has been freed under the cartridge guide and is clear of the pegs and indentations. The tongue of the body cover ensures that a cartridge is made to fall clear of the centre block of the magazine if it does not drop by its own weight.

- (ii) With cartridge guide removed show where pressure is brought to bear on the round.
- (iii) Replace cartridge guide, remove butt, body cover, and show that, owing to the two shoulders on the body, the round cannot be forced into the body.
- (iv) Re-assemble the gun and teach the mechanism of the half-fed round. Show the partial feeding of the round, the magazine going back slightly, cocking handle stopping in the 2nd position, due to round being jammed between lip of centre block and left side of cartridge opening in the feed arm.
- (v) Show how "I.A." remedies the jam.

3rd Position

(e) *Double feed (1st Phase).*

To reproduce for reasoning.—Load with full magazine, press No. 2 right stop pawl back, force magazine round as far as possible, hold magazine firmly with the left hand and position the cocking handle in the 3rd position.

Mechanism concerned:—

- (i) *Teach action of No. 2 right stop pawl and spring.*—During the "backward" action as the feed arm moves from right to left, the spring retaining stud passes over to the left and releases the pressure on the No. 2 right stop pawl, which is then pressed forward by its spring and engages the magazine. This prevents the magazine rotating too far. During the forward action, as the feed arm moves from left to right, the spring retaining stud presses back the No. 2 right stop pawl out of the path of the magazine. This compresses the stop pawl spring.
- (ii) With magazine on, show action of No. 2 right stop pawl.
- (iii) With a cut magazine show why the gun stops in 3rd position. The second round being forced under the cartridge

guide compresses the cartridge guide spring. This takes the pressure away from the round in the feed-way allowing its nose to drop. When the bolt comes forward it rides underneath the base of the round, causing the gun to stop in the 3rd position.

- (iv) Show how "I.A." remedies the stoppage. Pulling back the cocking handle removes the bolt from under the round in the feed-way. Counter-rotation of magazine replaces the second round in the magazine, thereby allowing the cartridge guide to position the round correctly in the feed-way.
- (v) Instructor must now explain that this stoppage will in all probability recur when the damaged part of the magazine comes round again, *i.e.* after firing four or five bursts. "I.A." will again cure the stoppage.

2nd Position followed by 3rd Position

(f) *Double feed (2nd Phase).*

To reproduce.—Load with full magazine and set the stoppage as when teaching "I.A.", *i.e.* live round in the chamber and cocking handle in 3rd position.

Instructor points out the condition of the gun, *i.e.* two live rounds, one in chamber and one

trying to go in, and explains that it is another form of double feed known as the 2nd Phase. The cause is as in 1st Phase.

Mechanism concerned (use a cut magazine).— Show why gun stops 2nd and will not fire 3rd. If the magazine does not rotate quite as far as in the 1st Phase, the second round will not be forced so far under the cartridge guide. In this case the pressure of the cartridge guide is not completely taken off the round in the feed-way and when the bolt comes forward it will carry the round either partially or fully into the chamber. The cocking handle will stop in the 2nd position owing to the second round being half fed. When "L.A." is performed the second round is completely fed and, on pressing the trigger, it is prevented from going into the chamber owing to a round being already there; consequently the cocking handle stops in the 3rd position.

Instructor now explains that if a double feed recurs after firing one or two rounds the gun must be cleared, the stop pawls spring changed, and the right stop pawl examined for wear.

Method of clearing gun.—Clear top round over the top and fire the round in the chamber.

This type of double feed will be practised now and during handling exercises.

(g) *Words of command* :—

(i) "Gun is firing all right." "Stops 3rd, magazine counter-rotates." "Fires one or two rounds and stops again 3rd, magazine counter-rotates."

After changing stop pawls spring:
"Gun is firing all right."

(ii) "Gun is firing all right." "Stops 2nd, won't fire 3rd." "Fires one or two rounds and stops again 2nd." "Won't fire 3rd." "Gun is firing all right," or "Gun is firing all right—stops 3rd—magazine counter-rotates." "Fires one or two rounds and stops 2nd—won't fire 3rd." "Gun is firing all right." (Or *vice versa*.)

13. Probable stoppages

LESSON 12.—PRO

Object.—To teach the man how to recognize probable without waste of time.

Method and sequence of teaching.—

1. Man applies Immediate Action until stoppage is
2. Instructor sets up or reproduces stoppage when
3. Question and answer, going by the Most Direct
4. Teach remedy by question and answer.
5. Teach mechanism concerned.
6. Squad practises in pairs by word of command.

Note.—In the case of a breakage, when it is impossible through, the magazine will be removed and the gun

Position	Cause and name	Remedy	Mechanism	Practice
(1) 1st.	(2) Broken or weak feed arm pawl spring, or worn pawl, or broken striker.	(3) Clear gun, examine feed arm pawl and spring; if defective, change and continue firing. If all right, change piston rod and continue firing.	(4) Recapitulate mechanism taught in damaged magazine stoppage.	(5) By word of command. Mention T.E.T. for broken striker.

and mechanism concerned

BABLE STOPPAGES

stoppages, their cause, and to apply the correct remedy

met with.

necessary.

method to get at the cause.

to pull the cocking handle back with a double pull-disconnected.

Instructors only		
Teaching cause of stoppage	Handling exercises	Range
(6) Remove feed arm pawl and spring, state "Gun is firing all right." "Gun stops." "Won't fire." "Still won't fire." When reasoning cause, having brought out that it is due to either feed arm pawl or spring, bring out that had there been a live round in the chamber the cause of the stoppage would be a broken striker.	(7) Words of command: "Gun is firing all right." "Gun stops." "Won't fire." "Still won't fire." When man feels pawl state: "Spring weak." After he changes it state "Gun is firing all right." If a broken striker is intended:— Same words of command as above, and when man examines feed arm pawl don't make any statement.	(8) 1st magazine: Few live rounds, two dummies, few live rounds. — 2nd magazine: The first round to come out must be a dummy followed by a few live rounds.

Probable Stoppages—*continued*

Position	Cause and name	Remedy	Mechanism	Practice
(1) 2nd.	(2) *Friction.	(3) Clear gun. Strip down and clean. If this is not possible, apply the following temporary remedy: unload, clear gun, take about three pounds off return spring and oil working parts (using oil from holdall).	(4) Recapitulate mechanism of hard extraction stoppage.*	(5) By word of command.

* If this stoppage recurs, continue applying I.A. until an cleaned and the weight readjusted.

Instructors only		
Teaching cause of stoppage	Handling exercises	Range
(5) "Gun is firing all right." Position cocking handle in 2nd Position and state: "Gun stops." After man applies "I.A." re-position in 2nd, stating: "Fires a few rounds and stops again."	(7) Words of command: "Gun is firing all right." "Stops 2nd." "Fires a few rounds and stops again 2nd." "Firing all right."	(8) Few live rounds, one dummy, few live rounds. One dummy, few live rounds. Position cocking handle in 2nd each time gun stops on a dummy.

opportunity occurs to clean the gun, when it should be thoroughly

Probable Stoppages—*continued*

Position	Cause and name	Remedy	Mechanism	Practice
(1) 3rd.	(2) Broken extractor.	(3) Clear round from feed-way over the top, leave empty case in chamber and change bolt. The empty case will be cleared by new bolt when loading.	(4) Show correct feeding of round from feed-way to chamber, bringing out how top extractor takes round forward and how shoulders on body assist in this feeding. How extractors grip rim of round and draw out empty case. Explain that empty case may not always be fully in chamber, but if partially in chamber it will always be in front of head of ejector. If the shank of an extractor breaks, the gun will stop in any position. This is due to the broken piece dropping into the body.	(5) By word of command. Mention T.B.T.

Instructors only		
Teaching cause of stoppage	Handling exercises	Range
(6) "Gun is firing all right." "Head away, finger off trigger." Cock gun and place empty case in chamber; ease cocking handle forward and order man to carry on firing, stating: "Gun stops." "Will not fire."	(7) Words of command: "Gun is firing all right." "Stops 3rd." "Will not fire 3rd." "Empty case in chamber." "Gun is firing all right."	(8) Few live rounds, one dummy, few live rounds. When gun stops on dummy state: "Finger off trigger, head away." Cock gun, place empty case in chamber, ease cocking handle forward; state "Carry on firing."

14. Possible stoppages

LESSON 14.—POS

Object.—To teach the man to recognize possible without waste of time.

Method and sequence of teaching.—

1. Instructor puts the gun into the condition it
2. Question and answer, going by the most direct
3. Teach remedy by question and answer.
4. Teach mechanism concerned.
5. Squad practises in pairs.

Position	Cause and name	Remedy	Mechanism	Practice
(1) 1st.	(2) Worn No. 1 left stop pawl.	(3) Clear gun and change left stop pawl.	(4) Mechanism of No. 1 left stop pawl. Show how pawl and spring is compressed by magazine. Show that when projection on magazine passes pawl, spring ensures that pawl goes into correct position. Show that if pawl is worn working parts will go forward on nothing. Show what happens when man applies "I.A."	(5) By word of command.

and mechanism concerned

SIBLE STOPPAGES

stoppages, their cause, and to apply the correct remedy

would be when the stoppage occurs. method to get at the cause.

Instructors only		
Teaching cause of stoppage	Handling exercises	Range
(6) To set for reasoning: See that chamber is empty, cocking handle forward, and place a full magazine on the gun. Explain that gun has been firing single shots, and when "I.A." was applied the magazine rotated about one space.	(7) Words of command: "Gun is firing all right." "Gun stops." "Fires one round and stops again." "Gun is firing all right."	(8) Few live rounds, one dummy, one live round, one dummy. Few live rounds.

Possible Stoppages—*continued*

Position	Cause and name	Remedy	Mechanism	Practice
(1) 2nd.	(2) Separated case.	(3) When gun will not fire pull back cocking handle (using double pull-through if necessary), clear round over top. To remove separated case, insert tapered portion of clearing plug, with centre pin pushed back, into chamber. Press the trigger allowing the bolt to force the centre pin forward, give the clearing plug handle an up-and-down rocking motion, pull back cocking handle, lever back the handle of the plug and withdraw from chamber. Press the trigger, load and continue firing. To remove the separated case from the clearing plug, knock the centre pin back.	(4) Nil.	(5) By word of command.

Instructors only

Teaching cause of stoppage	Handling exercises	Range
(6) To set for reasoning: Load with full magazine, place separated case in chamber and press the trigger. State that "I.A." has been applied and gun won't fire. As soon as it is seen that a live round is trying to enter the chamber, state that the obstruction is due to a separated case.	(7) Words of command: "Gun is firing all right." "Stops 2nd." "Will not fire 2nd." "Gun is firing all right."	(8) Not to be set up.

Possible Stoppages—continued

Position	Cause and name	Remedy	Mechanism	Practice
(1) 3rd.	(2) Weak cartridge guide.	(3) Clear gun by firing and change cartridge guide.	(4) Nil.	(5) By word of command.
3rd.	Broken cartridge guide.	Clear gun and change cartridge guide.	Nil.	By word of command.
3rd.	Worn or broken ejector.	Clear gun without firing, with the assistance of No. 2, who will help by tilting the gun over, using the mounting to do so; shake the live round and empty case through the ejection opening and change ejector.	Mechanism of the ejector, remove butt, body cover, feed arm, ejector cover and disconnect. Show action of ejector by working cocking handle backwards and forwards. Point out that, on backward action, lug on left side of feed-arm actuating stud knocks tail of	Must be set up for every man.

Instructors only		
Teaching cause of stoppage	Handling exercises	Range
(6) To set for reasoning : Load with full magazine, place the point of a dummy through the ejection opening and press down the nose of the cartridge in the feed-way. Keeping the nose pressed down, press the trigger. State that the gun will fire a few rounds and stop 3rd, but there is no counter-rotation of the magazine.	(7) Words of command : "Gun is firing all right." "Stops 3rd." "Fires a few rounds and stop again 3rd." "Firing all right."	(8) Not to be set up.
To set for reasoning : Remove cartridge guide, load with full magazine and press the trigger. State that "I.A." has been applied and the gun won't fire.	Words of command : "Gun is firing all right." "Stops 3rd." "Won't fire 3rd." "Nose of bullet hanging down." "Gun is firing all right."	Not to be set up.
To set for reasoning : Load with full magazine, place empty case in the body with the rim just in rear of head of ejector, press the trigger. State that "I.A." has been applied and the gun won't fire.	Not to be set up as the correct method of clearing gun can not be practised.	Few live rounds, one dummy, few live rounds, when gun stops on dummy state : "Head away, finger off the trigger," cock gun and place in empty case just in rear of head of ejector, then state : "Carry on firing."

Possible Stoppages—continued

Position	Cause and name	Remedy	Mechanism	Practice
(1)	(2)	(3)	(4)	(5)
			ejector in, thus knocking head out, on the forward action; how opening on face of bolt hits head of ejector and forces it in, thus forcing tail out. Show this again with bolt and ejector out of gun and having dummy on the face of the bolt. Point out how empty case is hit centrally and close to rim.	
Any.	Broken return spring.	If gun stops 1st or 3rd, clear round over top, inspect chamber, push cocking handle forward and change pinion. If gun stops 2nd, clear round from feed-way over top, with the assistance of No. 2 shake round from chamber through ejection opening, push cocking handle forward and change pinion.	Nil.	By word of command.

Instructors only

Teaching cause of stoppage	Handling exercises	Range
(6)	(7)	(8)
To set for reasoning: Remove pinion group and replace with spare pinion casing, re-assemble, load and position cocking handle in 1st or 3rd Position. Having reasoned cause and remedy, set up as above, but having loaded, push cocking handle forward until round is in chamber, then put cocking handle in 2nd Position. Teach remedy.	Words of command: "Gun is firing all right." "Gun stops . . . position, no resistance on cocking handle." "Gun is firing all right."	Not to be set up.

15. *Additional mechanism*

LESSON 15.—ADDITIONAL MECHANISM

1. *Preliminaries.*

Stores required :—

- i. D.P. gun, magazines, spare parts, dummies and ground sheets.
- ii. Inspect gun and dummies.

2. *Sequence of instruction.*

i. Instructor states object of lesson: To teach mechanism which has not been taught in "*Mechanism and Stoppages.*"

ii. This lesson will be divided into three parts :

- (a) Cooling system.
- (b) Object of straight portion of cam slot on bolt.
- (c) Other mechanism.

3. *Cooling system* (remove front radiator casing and clamp ring).

- i. Describe and give object of radiator. Made of aluminium with projecting flanges which, by increasing the area exposed to the air, assists in dissipating the heat of the barrel.
- ii. Action of the gas after the bullet has passed the gas vent. Explain that the gas forces the bullet out of the barrel and, owing to the shape of the barrel mouthpiece, the gases are directed into the front radiator casing in a fan shape.

These gases force the air out of the front radiator casing, thereby causing a flow of cool air along the radiator from the rear of the gun.

iii. Remind squad of the method of firing, *i.e.* in bursts of from four to five rounds, to assist in the cooling.

4. *Object of straight portion of cam slot on bolt.*

- i. Explain how far the bullet has to travel after passing gas vent before it leaves the muzzle (four inches).
- ii. Explain how far gases which pass through gas vent have to travel before they have driven the piston rod back far enough to commence the unlocking of the bolt (about four inches).
- iii. Point out that this ensures that the bullet has left the muzzle before the breech is opened.
- iv. Explain that during the forward action the bolt is completely locked before the straight portion of the cam slot is in correct alignment with the striker post. This ensures that the breech is closed before the round can be fired. From this it can be seen that the straight portion of the cam slot is a "Mechanical Safety Device."

5. *Other mechanism.*

- i. *Magazine stop pawls incorrectly assembled.*—This means that the No. 2 right stop pawl would be placed on the No. 1 left stop pawl stud, thereby causing the club foot to be to the left and pointing downwards. On pulling back the cocking handle, the magazine rotates

and pushes back the No. 2 right stop pawl. The feed arm cannot move completely to the left owing to the feed arm pawl spring stud becoming jammed with the club foot on the No. 2 right stop pawl. This would prevent the gun from being loaded.

ii. *Ejector cover incorrectly assembled.*—Owing to the ejector cover not being pushed fully home, the rear end would be resting on the body. The ribs on the underside of the body cover prevent the tail of the feed arm from lifting, therefore on pulling back the cocking handle the left side of the tail of the feed arm would come up against the rear end of the ejector cover. This would prevent the gun from being loaded.

iii. *Feed arm actuating stud not screwed up correctly, i.e. boss downwards.*

(a) *Why the gun will not fire.*—Owing to the boss being downwards it is not engaged with the groove in the tail of the feed arm, therefore the feed arm is not moved across and the gun is not loaded.

(b) *If a magazine is placed on the gun with the feed arm over to the right, why the cocking handle cannot be pulled back.*—On rotating the magazine, the cartridge coming up against the cartridge stop causes the feed arm to move to the left. This allows the cartridge to move to the left until it is resting on the bolt

between two locking lugs and positioned under the cartridge guide. On pulling back the cocking handle the bolt is prevented from rotating owing to the cartridge being jammed between the cartridge guide and the locking lug on the bolt.

(c) *Why cocking handle may not go right forward.*—The feed arm actuating stud being unscrewed half turn has caused the bolt to be lengthened. In the case of most Lewis guns while assembling, when the front of the bolt hits the head of the ejector the tail will be prevented from pivoting into the boltway as it will come in contact with the actuating stud.

(d) *One complete turn, i.e. boss uppermost.*—The gun cannot be assembled owing to the bolt not being able to pass the ejector.

iv. *Depression on cartridge guide.*—This is to allow the rim of the cartridge to move under the cartridge guide during the forward action of the gun.

v. *Club foot on No. 2 right stop pawl.*—This is to bring it level with the underside of the body cover which enables it to engage with the magazine at the same height as the No. 1 left stop pawl; also it offers a larger surface to come in contact with the projection in the magazine.

- vi. *Depression on the feed arm.*—This assists in the control of the cartridge to the chamber by preventing any upward movement of the bullet.
- vii. *Separating peg way on feed arm.*—This allows the feed arm to move to the right when the magazine is stationary.
- viii. *Positioning stud on tail of feed arm.*—When the bolt is fully to the rear the boss on the actuating stud has left the tail of the feed arm. The positioning stud is engaged between the end of the recess in the body and the left side of the top lug on the bolt. This holds the feed arm in position until the boss on the feed arm actuating stud again enters the groove in the tail of the feed arm.
- xi. *Why the tail of the ejector is bent.*—To bring it to the same level as the left lug of the bolt.
- x. *Why a small portion is cut away on left lug of bolt.*—During the backward action the tail of the ejector may rebound slightly into the boltway. In this case the cut away portion will cause the tail to be pushed out of the boltway during the forward action.
- xi. *Allowances for expansion of extractors.*—The left side and the top of the boltway in the body are grooved to allow for the above.
- xii. *Object of barrel lips.*—On the rear face of the barrel are projections which support the base of the cartridge and allow the extractors to grip the rim of the cartridge.

- xiii. *Mechanism of magazine catch (use cut magazine).*—When the magazine is placed on the gun, the magazine catch is forced to the right, which compresses the magazine catch spring and removes the nib of the catch from the recess in the ring. This allows the magazine to rotate. When the magazine is removed the magazine catch spring forces the magazine catch out, which causes the nib on the catch to engage with the recess in the ring. This prevents the magazine from rotating.

HANDLING

16.—General

1. This training corresponds to fire discipline training (rifle) in Vol. I, 1931, Sec. 34, and has the same objects in view.
2. The characteristics of the Lewis gun and its maintenance in action demand the performance of special duties by the men of the light automatic section in addition to the same duties as are required of the men of a rifle section.
3. Training in handling, therefore, is based on fire discipline training (rifle) with such additions and modifications as will ensure that the object of the training will be achieved.
4. Handling is divided into four parts—Part I (Elementary), in which every man of a light automatic section is trained in the duties of Nos. 1 and 2 as a drill. This

corresponds to the 1st or elementary stage of fire discipline training (rifle).

5. Parts II, III and IV are more advanced and correspond to the 2nd, or advanced stage of fire discipline training. Part II consists of training men as Nos. 1 and 2 to mount the gun on any type of ground. Part III is training in the duties of Nos. 3, 4, 5 and 6. When the light automatic is carried on pack animals, this part will also include the training of the additional numbers required, *i.e.* Nos. 7 and 8. In Part IV the complete section is trained to work as a team.

17. *Elementary handling (Part I)*

1. This part is purely drill and will be carried out on any piece of level ground. An aiming mark on a landscape target will always be indicated.

2. When each man has had sufficient practice to enable him to carry out instinctively the correct action on any given word of command, the instructor will introduce handling exercises.

The object of these exercises is to quicken Nos. 1 and 2 in handling the gun. Accuracy must not be sacrificed for speed, however, and mistakes in points of elementary training will on no account be overlooked.

3. As progress is made in locating the causes of stoppages and applying the correct remedies practice in doing this will be introduced into handling exercises.

4. Several squads or sections can be exercised collectively under the control of one instructor. This provides

an opportunity for introducing competition between squads.

These collective exercises will be of no value unless—

- i. The instructor has a carefully prepared programme of items to be included in the exercise.
- ii. When more than two squads are being exercised simultaneously there must be a supervising N.C.O. with each squad.

LESSON 9.—ELEMENTARY HANDLING

5. *Preliminaries.*

- i. Stores required.—Gun, magazines, spare parts, landscape target and ground sheets.
- ii. Ground sheets placed to represent *action* and *cease firing* positions as under :—
 - (a) *Action* position.—Two sheets side by side.
 - (b) *Cease firing* position.—Two sheets about two yards apart and about five yards in rear of (a).
- iii. Gun, magazines and spare parts at *cease firing* position, the gun on right sheet.
- iv. Squad will fall in on right of the *action* position and number off.

6. *Sequence of instruction.*

- i. The instructor states object of lesson : To teach the action of Nos. 1 and 2 in handling the gun on level ground in the open.

Stage I. Take Post and Clear Gun

ii. "Take Post." Action of No. 2.

Instructor demonstrates action of No. 2 on command "Take Post," giving detail as follows:—

- (a) Gets down and examines *magazines*.
- (b) Passes one *magazine* to No. 1 (imaginary) and puts remainder back in carrier.
- (c) Examines *spare parts holdall*, opening outer flap to ensure the pockets are fastened. Re-fastens outer flap.
- (d) Reports to No. 1: "Magazines and spare parts correct."

iii. Instructor questions squad on points given in sub-para. ii, above, and gives reasons for certain items as follows:—

- (a) Magazines examined to see that they are correctly filled and not damaged.
- (b) No. 1 requires a magazine on the gun for "Action." Remainder placed in carrier for carrying forward, to keep them clean and prevent damage.
- (c) Holdall examined to see that it is securely fastened so that spare parts will not fall out.
- (d) To let No. 1 know that No. 2 has carried out his duties.

iv. "Take Post." Action of No. 1.

Instructor demonstrates action of No. 1 on command "Take Post," giving detail as follows:

- (a) Gets down behind gun and examines it from front to rear as taught in "*Points before Firing*," Lesson 8.
- (b) Places magazine on gun.
- (c) Reports to section commander: "No. . . . gun ready."

v. Instructor questions squad on points given in sub-para. iv, above, and gives reasons for certain items as follows:—

- (a) As in "*Points before Firing*," Lesson 8.
- (b) To prevent delay in opening fire on coming into action.
- (c) To let the section commander know that Nos. 1 and 2 are ready.

vi. "Clear gun." Action of No. 1.

Instructor demonstrates action of No. 1 on command "Clear gun," giving detail as follows:—

- (a) Remove magazine.
- (b) With gun in the shoulder, pull back *cocking handle* and press *trigger*.
- (c) Spring to attention and report "Gun clear."

vii. "Clear gun." Action of No. 2.

Demonstrated as in vi.

- (a) Replace the magazine in the carrier.
- (b) Spring to attention.

No. 1 will not report "Gun clear" until both numbers are at attention.

- viii. Instructor questions squad, giving reasons as taught in Lesson 2—Unloading.
- ix. Squad practises in pairs, each man performing the duties of both No. 1 and No. 2.

Stage II. Action

7. Sequence of instruction.

i. Instructor orders two of the squad to "Take Post." When gun is reported "ready" tells them to join the squad.

ii. Action of No. 1.

Instructor demonstrates action of No. 1 on command "Action," giving detail as follows:—

- (a) Jump up quickly.
- (b) Right hand grasps the *small of the butt*.
- (c) Left hand grasps the *bipod*, palm of the hand to the front, pressing the *legs* forward, wrist clear of the *radiator casing*.
- (d) Double to the *action* position.
- (e) Place the *bipod* on the ground gently.
- (f) As the *bipod* reaches the ground, transfer the *butt* to the left hand.
- (g) Place the right hand on the ground, and lie down behind the gun.
- (h) Lower the *butt* to the ground.
- (j) Load.

iii. Instructor questions squad on points given in sub-para. ii, above, and gives reasons for certain items as follows:—

(b) Most convenient place.

(c) By pressing the palm forward against the bipod legs they are in a position to be mounted quickly. The radiator casing gets hot with firing, and the hand or wrist will be burnt if they touch it in that state.

(e) To avoid damage.

(f) and (g) To enable the right hand to be used to break the fall and prevent weight being placed on the butt. Method of getting down is similar to that when using the rifle.

(j) To avoid delay in opening fire.

iv. Action of No. 2.

Instructor demonstrates action of No. 2 as in ii, one of the squad lying behind the gun as No. 1.

(a) Jump up, pick up the *holdall* by the handle with the left hand, wallet end to the front. Pick up the *carrier* with the right hand. Double to the *action* position on the left of No. 1.

(b) Place the *holdall* on the ground, flap uppermost, wallet end nearest the gun, and place the *carrier* in a convenient position.

(c) Lie down close to No. 1 without hindering his movements.

- (d) Take a *magazine* out of the *carrier*, holding it in the right hand so that the *magazine catch* is to the right.
- (e) Watch the section commander.
- v. Instructor questions squad on points given in sub-para. iv, above, and gives reasons for certain items as follows:—
- (a) Method of carrying holdall is for quickness in placing it in the correct position at the *action* position.
- (b) Flap uppermost for speed in opening holdall. Majority of spare parts needed are in the wallet.
- (c) Must be close in order to assist No. 1, and also makes smaller target.
- (d) As taught in Lesson 2—Loading.
- (e) Watching for signals.
- vi. Instructor demonstrates and explains action of No. 2 in assisting No. 1 to unload. After gun is reported clear orders them to take the kit back to *cease firing* position.
- vii. Squad practises in pairs, each man acting as No. 1 and No. 2. Instructor's words of command for this will be: "Action"—"Unload."
- viii. Instructor gives conditions of test (Sec. 20).

Stage III. Aiming and Firing

8. Sequence of instruction.

- i. *Preliminaries*.—Gun to be in the *action* position.

When this stage starts a fresh period the instructor will order two of the squad to "Take post," and when the gun is reported ready will order "Action." This applies also to Stages IV, V and VI.

- ii. Instructor demonstrates with detail where necessary, giving himself the required orders.

Action of No. 1.

- (a) On range being given, adjusts the *sights* to that ordered.
- (b) On target being indicated, he aims; when the aim is correctly taken he says "On."
- (c) On the command "Fire," fire as already taught.

Action of No. 2 (one of the squad acting as No. 1).

- (d) On the word "On," No. 2 places his right hand over the back of No. 1.
- (e) On the order "Fire," No. 2 withdraws his right hand.

- iii. Instructor questions squad on points given in sub-para. ii, above, and gives reasons for certain items as follows:—

- (b) No. 1 says "On" to let No. 2 know he is ready.
- (d) To indicate to the section commander that the gun is ready to fire.

- iv. Squad practises in pairs.

Stage IV. Changing Magazines

9. Sequence of instruction.

i. *Preliminaries.*—See Stage III. The *cocking handle* to be in the forward position. One of the squad will act as No. 2.

ii. Instructor explains:—

Action of No. 2.

- (a) On the word "Up" from No. 1, No. 2 will press up the *magazine* with the left hand.
- (b) When the empty *magazine* is clear off the gun No. 2 will place a full *magazine* on the post.
- (c) He will take the empty *magazine* from No. 1 and place it in the *carrier*.
- (d) He will take out a full *magazine* from the *carrier*.

iii. Instructor demonstrates action on command "Change," giving detail:—

Action of No. 1.

- (a) Keep the *butt* in the shoulder.
- (b) Press in *magazine catch* and shout "Up."
- (c) With the assistance of No. 2 remove the *magazine* and pass it under the gun to No. 2.
- (d) When new *magazine* is on the *post*, load, aim and fire.

PLATE 4 LEWIS GUN

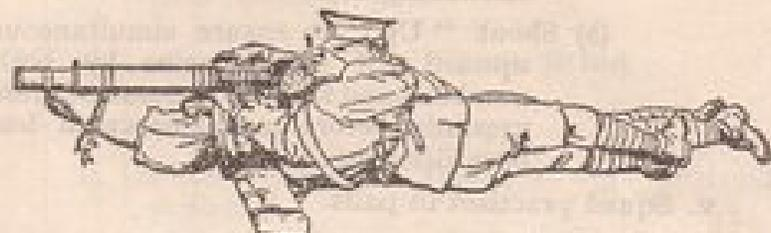


FIG. 1.—"CHANGE"—1ST PHASE



FIG. 2.—"CHANGE"—2ND PHASE

iv. Instructor questions squad on points given in sub-para. iii, above, and gives reasons for certain items as follows:—

- (a) Butt in the shoulder to avoid delay in continuing fire.
- (b) Shout "Up" to ensure simultaneous upward lift of magazine by both numbers, and that No. 2 does not press upwards before magazine catch has been disengaged.

v. Squad practises in pairs.

Stage V. Stop and Go on

10. *Sequence of instruction.*

i. *Preliminaries* as in Stage IV.

ii. Instructor demonstrates, giving detail:—

Action of No. 1.

- (a) On the command "Stop" change magazines and lower the butt to the ground. *Backsight* remains up.
- (b) On the command "... target . . . Go on," aim and fire.

iii. The instructor will explain that whilst firing ball ammunition, on releasing the *trigger*, provided there are rounds left in the *magazine*, the working parts will remain in the rear position. The action taught is the correct one for service conditions.

iv. Instructor questions squad, giving reasons:—

- (a) Change the magazine to ensure that there is a full magazine ready for firing the next burst or bursts.

v. Squad practises in pairs.

Stage VI. Cease firing

11. *Sequence of instruction.*

i. *Preliminaries* as in Stage IV.

ii. On the command "Cease firing" instructor explains:—

Action of No. 2.

- (a) Assist in removing *magazine*.
- (b) Place full *magazine* on when ordered.
- (c) Return remaining *magazine* to *carrier*.
- (d) Pick up *holdall* and *magazine carrier*, return to *cease firing* position and lie down.

Instructor demonstrates, giving detail:—

Action of No. 1.

- (e) With the butt in the shoulder remove the *magazine*.
- (f) Press the *trigger*.
- (g) Clear gun.
- (h) Order "Magazine on."
- (j) Lower the *backsight leaf*, pick up the gun as in "Action," return to *cease firing* position and lie down.

iii. Instructor questions squad on points given in sub-para. ii, above, and gives reasons for certain items as follows :—

(f) and (g) Pressing the trigger and clearing the gun to ensure that gun will not be carried loaded.

(h) To ensure gun is always ready for action.

iv. Squad practises in pairs Stages II, III and VI combined. Instructor gives conditions of test (Sec. 20).

v. Instructor will explain that if the command "Cease firing" is given before fire has been opened the gun must be unloaded without firing.

Stage VII. Signals

12. Sequence of instruction.

i. Instructor demonstrates, giving detail :—

(a) "Action." Both arms raised and lowered in line with the shoulders.

(b) "Stop." Hand waved horizontally.

(c) "Cease firing." Arm circled from the shoulder.

ii. Instructor repeats signals, questioning squad on their meaning.

iii. Squad practised in all stages of Lesson 9, signals being employed where applicable.

iv. The term "out of action" means that the gun is no longer capable of producing fire, e.g. no ammunition, a prolonged stoppage.

18. Advanced handling (Part II)

1. This part is designed to teach and practise men as Nos. 1 and 2 :—

i. To use ground correctly in occupying a fire position.

ii. To mount the gun so that full fire effect can be obtained combined with a minimum of exposure for Nos. 1 and 2.

2. This will be carried out on ground on which there are minor irregular features, use being made of both natural and artificial cover. *Natural targets will be described.*

3. The following will be included :—

i. Mounting the gun without the bipod legs (Plate 6).

ii. Occupying a fire position with the minimum of exposure. This may necessitate crawling for the last few yards.

iii. Mounting the gun using the bipod legs.

iv. Firing round cover.

v. Firing the gun from behind low continuous cover (Plate 5).

vi. Firing on the side of a slope.

vii. Carrying the gun assisted by No. 2 (both crouching).

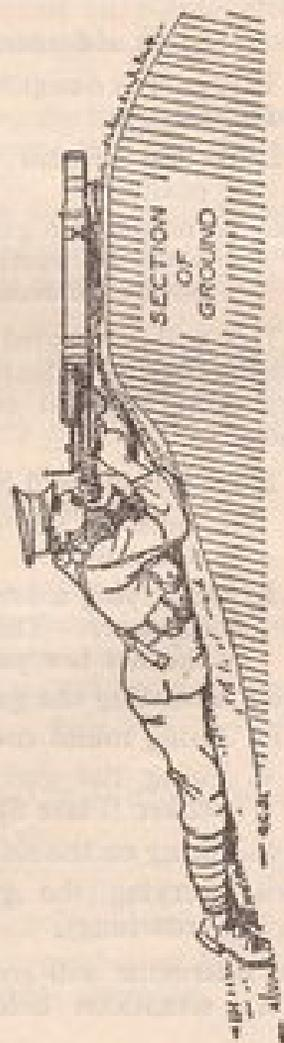
The instructor will reconnoitre the ground and prepare his situations beforehand. As a preliminary to

PLATE 5
MOUNTING THE GUN



Low continuous cover

PLATE 6
MOUNTING THE GUN



Bipod legs folded—Gun rested on ground

advanced handling the following will be taught before commencing Lesson 13:—

- (a) Fitting and use of the carrying handle.
- (b) Fitting and use of the sling.

This should be taught in barracks.

To fit the carrying handle.—Place the *gun band* of the *handle* over the junction between the body and the *rear radiator casing*, slide it forward until it is seated between the two *mounting rings* on the *rear radiator casing*, pass the *screw bolt* through and screw on the *wing nut*.

To fit the sling.—Holding the sling with the asbestos covering downwards and to the rear, pass it through the *butt sling swivel* from front to rear; bring it forward and pass it through the *buckle* of the sling; then pass it through the *front sling swivel* from rear to front. Secure the two clips.

When progress in advanced handling has been made, handling exercises on uneven ground will be included.

LESSON 13.—ADVANCED HANDLING

4. Preliminaries.

- i. Stores required.—Gun with carrying handle and sling, magazines, spare parts.
- ii. Inspect gun and dummies. Attach carrying handle and sling. Fall in the squad on the right of the gun.

5. Sequence of instruction.

- i. Instructor states that the object of the lesson is to teach men acting as Nos. 1 and 2 the use

of ground, so that in occupying a fire position they can use the gun with full fire effect with a maximum amount of cover for themselves. Squad to imagine advance taking place.

ii. Example of i, above :—

Instructor demonstrates and explains action of No. 1 on the command "Action." Then, using one of the squad to act as No. 1, instructor demonstrates and explains actions of No. 2 on the command "Action."

iii. Instructor interrogates squad on actions of Nos. 1 and 2.

iv. Instructor demonstrates :—

"Aiming and Firing," "Change," "Stop" and "Cease Firing."

v. Instructor, using different members of the squad to act as No. 2, repeats this demonstration two or three times with remainder of squad viewing from out in front of the cover.

vi. Squad practises in pairs.

vii. Instructor demonstrates how a No. 1 should crawl into a fire position so as to avoid enemy observation.

A method of carrying the gun when crawling into position.—Lie down on the left side with the left knee drawn up, then turn the gun over so that the top of magazine rests on the inside of the left knee. Holding one leg of the bipod with the right hand, crawl to the desired place

by exerting pressure on the left forearm and, at the same time, pushing forward with the right foot.

viii. Squad practises individually.

6. In all subsequent examples the instructor will not himself demonstrate but will practise the squad direct, allowing them to use their own judgment in mounting the gun and occupying the position. The remainder of the squad will be called upon to criticise.

When teaching how to fire the gun over cover without using the legs of the bipod it should be explained that, if possible, the cover should support the gun as nearly as possible at the same place as the bipod legs normally support it—otherwise the sighting of the gun will be affected.

The number of men actually practised in each example will depend upon the standard of intelligence of the squad and on the time available.

19. Section handling (Parts III and IV)

1. Training in Parts III and IV will be based on the principles stated in fire discipline training (rifle) in Vol. I, 1931, Sec. 34, 10-15, the application of those principles being modified to meet the requirements of the training of a light automatic section.

2. Section handling, Part III, is designed to train each man in a light automatic section to perform the duties of Nos. 3, 4, 5 and 6, and to be able to undertake any of these duties at any moment.

3. As the number of men in a section at any particular moment may vary, the system of carrying out these duties must be sufficiently flexible to meet any variation in strength. The necessity for training the extra numbers of a *pack* light automatic section must also be borne in mind.

4. The main duties are :—

- i. To carry and replenish ammunition.
- ii. Protection. Scouting or other protective duties.
- iii. Riflemen.

5. Normally they will be distributed as under :—

No. 3 responsible for ammunition supply between No. 2 and Nos. 4, 5 and 6. Nos. 4, 5 and 6 ammunition carriers, protective duties and riflemen. (For light automatic sections when the gun is carried on *pack*, see Appendix III.)

6. The following will be practised :—

- i. Method of carrying ammunition.
- ii. Transfer of full and empty magazines between Nos. 2 and 3.
- iii. Collection by No. 3 of full magazines from other numbers, and disposal of empty magazines.

7. For training purposes the *normal* scale of ammunition to be taken into action will be considered to be as follows :—

Carried by the section commander	...	1 magazine in a pouch suspended to belt on the left end piece of the waist-belt.
----------------------------------	-----	--

Carried by No. 1	1 magazine on the gun.
" " No. 2	2 magazines in pouch equipment connected by the brace and hung round the neck with both magazines in front.

" " No. 3	} 4 magazines each in pouch equipment.
" " No. 4	
" " No. 5	
" " No. 6	

Total : 20 magazines = 940 rounds a gun.

Nos. 2 and 3 carry empty carriers for use when replenishing ammunition.

No. 1 carries a revolver and 18 rounds ammunition.

No. 2 carries the holdall containing spare parts, a revolver, and 18 rounds ammunition.

8. No. 3 will take up a position near the gun under cover, if possible, and will transfer his magazines from his pouches into his magazine carrier. In selecting his position he must remember that unless the cover is exceptionally good he should avoid being very close to the gun, while to be too far away may draw attention owing to movement in supplying ammunition.

9. When No. 2's supply of ammunition is finished, No. 3 will hand over his carrier to No. 2 and take away his carrier containing empty magazines.

10. No. 3 then goes to one of the other numbers, takes from him four full magazines, which he puts in his own carrier, and gives him the empty magazines. These will be refilled as opportunity offers.

11. As regards their duties other than that of carrying ammunition, Nos. 4, 5 and 6 will act in accordance with the instructions laid down in Infantry Training. The individual training in scouting and other protective duties comprises:—

- i. Training as laid down in Infantry Training.
- ii. Selecting suitable fire positions with particular reference to the requirements of a light automatic section.
- iii. Observation, *i.e.* watching:—
 - (a) The action of neighbouring sections and platoon headquarters.
 - (b) Hostile movement, especially targets affording opportunities for employment of enfilade fire.

12. Section handling, Part IV, is designed to practise men in carrying out all the duties learnt in the previous stages when working as a team under a leader. It will follow the principles set out for the conduct of the advanced stage of fire discipline training (*rifle*), and exercises will be framed so as to introduce the points mentioned therein.

13. Instructors will ensure that the members of a section do not always act as the same number.

14. This form of exercise can also be applied as a test of the efficiency of the men in the section to work as a team, on the lines of Inspection Test for a rifle section (*see Vol. I, 1931, Sec. 36, 5*).

15. The action of removing guns and ammunition from the company light automatic limber or pack animals

must be practised to ensure that this will be done quickly and with the minimum noise and confusion. (*See Appendices II and III.*)

TESTS OF ELEMENTARY TRAINING (LEWIS GUN)

20. *General instructions*

1. The general instructions laid down in Vol. I, 1931, Sec. 35, 1 to 4 (*Rifle*), apply equally to the Lewis gun.

2. i. Before firing Table "A," Part IV, on the 30-yards range the soldier will be required to pass tests 1 to 4.

ii. Before firing Table "A," Part VII, the soldier will be required to pass tests 1 to 8.

iii. Before firing Table "B," Part III, the soldier will be required to pass tests 1 to 10 and A.A. tests 1 to 4.

iv. Before firing Table "B," Part IV, the soldier will be required to pass the whole of the tests.

3. The passing of the tests must on no account be judged merely on the time limit, as accuracy of manipulation is the important consideration. Consequently, even though a man completes the test in the time limit but at the same time is incorrect in some part of the handling, or damages the gun or spare parts, he will be judged as having failed to pass the test. In all tests where No. 2 or No. 3 takes an active part, and where failure to pass by the No. 1 is obviously due to faulty manipulation by one of the other numbers, the No. 1 will be given another trial.

TESTS OF ELEMENTARY TRAINING (LEWIS GUN)

Name of test and stores required	Conditions before test	Manipulation tested	Time	Remarks
(1) 1. Loading. Gun — spare parts — magazines — diameters.	(2) Nos. 1 and 2 lying behind the gun. No. 2 to have a magazine ready, but not on the gun. <i>Get</i> on the ground. <i>Return spring</i> to be at the normal firing weight.	(3) 1. On the command "Load," No. 2 places magazine on the magazine board correctly. No. 1 rotates the magazine and pulls back the <i>cocking handle</i> . Gun to be properly loaded. 2. On the range being given No. 1 sets the <i>sights</i> .	(4) 3 seconds from the command "Load" until No. 1 has pulled back the <i>cocking handle</i> .	(5) He will be tested 4 times and should pass in 3 of them.
2. Adjustment of sights. Gun	No. 1 lying behind the gun. Sights to be at 600 yards. <i>Leaf of back sight</i> down.		4 seconds	A. maximum alteration in range of 600 yards up or down will not be exceeded. Each man to be tested 4 times, 3 of which must be correct.

3. Holding and aiming. Gun — spare parts, aiming disc.	No. 1 lying behind the gun. <i>Bolt</i> on the ground. <i>Gun clear</i> , no magazine on the gun. <i>Cocking handle</i> back.	3. Correct holding and aiming.	5 seconds from command "Go" until No. 1 has pressed the <i>trigger</i> .	The man will be tested 4 times, and must pass 3 out of 4 times. The <i>eye disc</i> should be held about 1 yard from the end of the <i>front radiator cap-iron</i> . The height of <i>eye disc</i> should be varied for each aim taken.
4. Unloading without firing. Gun — magazines filled with diameters.	No. 1 in the correct firing position with the gun loaded. <i>Cocking handle</i> back.	4. On the command "Without firing — Unload," No. 1, assisted by No. 2, removes magazine and the round in the <i>feed-way</i> .	15 seconds from the command "Go" until Nos. stand up.	—
5. Testing and adjusting the tension of the return spring. Gun — combination lock or spring balance.	No. 1 lying, Gun assembled, but with the tension of the return spring between 4 and 10 lb.	5. Tension adjusted to the normal firing weight of the gun and tested with the <i>spring balance</i> . Stripping and reassembling performed correctly.	55 seconds from the word "Go" until the gun is re-assembled.	To pass, the adjustment to be within $\frac{1}{4}$ lb. of correct weight.

Name of test and stores required	Conditions before test	Manipulation tested	Time	Remarks
(1) 6. Action, Gun, with a magazine on the post, but not loaded. Spare parts—web equipment—magazine carrier, with 2 magazines.	(2) No. 1 lying behind the gun, No. 2 two paces to the left of No. 1 and in the lying position.	(3) 6. On the command "Action" Nos. 1 and 2 will double forward independently. Gun to be mounted correctly on the spot indicated. Gun to be loaded, butt on the ground. Position of No. 1 to be correct.	(4) 9 seconds from command "Action" until No. 1 replaces his right hand on the pistol grip.	(5) "Gun mounted correctly" includes putting the legs of the field mount down gently and transferring the butt from the right to the left hand before No. 1 assumes the lying position.
7. Cease firing. Gun—spare parts—magazines—dummies—magazine carrier—landscape target.	Nos. 1 and 2 in the correct firing position. Gun loaded with the cocking handle back.	7. On the command "Cease firing," No. 1 unloads before he replaces a full magazine on the magazine post. Lower sights. Nos. 1 and 2 double back 5 yards. Gun to be carried and put down correctly.	12 seconds from command "Cease firing," until No. 1 is lying in the "Cease firing" position.	—

8a. "Immediate Action." Gun—spare parts—magazines—dummies—landscape target.	Four different L.A. stoppages selected from first five stoppages, i.e. up to Double Feed, 1st Phase lock, to be set up. Nos. 1 and 2 in the correcting position. The instructor will give the order "Fire," then "Gun stops—Position," and then either: "Gun does not fire," or after the "L.A." has been performed, "Gun fires all right."	8a. Immediate action performed correctly in all details.	5 seconds from the order indicating the cause of the stoppage, until No. 1 presses the trigger again.	In the case of the stoppage being due to a damaged magazine, the time will be taken from the last word of the command "Gun does not fire."
8b. Double Feed (2nd Phase). Stores as for 8, A.	Nos. 1 and 2 in the correct firing position. The instructor will give the order "Fire," then "Gun stops 2nd," and when L.A. has been performed, "Won't fire 3rd."	8b. Immediate action performed correctly in all details.	12 seconds from the command "Won't fire 3rd" until the gun is again firing.	—

Name of test and stores required	Conditions before test	Manipulation tested	Time	Remarks
(1) 9. Remedying a broken striker stoppage. Gun— <i>spare parts</i> — <i>magazines</i> — <i>dummys</i> — <i>landscape target</i> . D.F. gun to be used.	(2) Nos. 1 and 2 in the correct position for firing. No. 1 fires the gun and performs the "I. A." correctly until the cause of the stoppage is located to a broken <i>striker</i> , at which moment the test begins.	(3) 9. On the command "Gun still won't fire," No. 1 clears the gun and changes the <i>fusion rod</i> correctly; reloads, aims and fires. 10. On the command "Gun does not fire," No. 1 clears the gun correctly, changes the bolt, reloads, aims correctly and fires.	(4) 25 seconds. Having given the word of command "Gun still won't fire," time will be taken from the moment the cause of the stoppage is located until the gun is firing again.	(5) The instructor gives the command "Gun stops" and "Gun won't fire," and No. 1 performs the necessary <i>immediate action</i> before he gives the command "Gun still won't fire."
10. Remedying broken claw of extractor stoppage. Gun— <i>spare parts</i> — <i>magazines</i> — <i>dummys</i> — <i>empty cartridge case</i> — <i>landscape target</i> . D.F. gun to be used.	(2) Nos. 1 and 2 in the correct firing position. Gun is set up "for broken claw of extractor stoppage. (The test starts after No. 1 has applied "I. A." when the instructor gives the command "Gun does not fire.")	(3) 10. On the command "Gun does not fire," No. 1 clears the gun correctly, changes the <i>aiming device</i> and fires.	(4) 40 seconds from the command, "Gun does not fire" until gun is again firing.	(5) —

CHAPTER II

GRENADE TRAINING

21. Definitions

Bomber.—A soldier who, in addition to the other weapons, is armed with a grenade.

Grenade.—The weapon used by the bomber. It may be:—

- i. A high explosive (H.E.) grenade.
- ii. A smoke grenade.
- iii. A signal grenade.

Live grenade.—A grenade filled with any explosive mixture.

Segmentation.—The cross-grooving of the bodies of certain grenades to induce the formation of fragments of a certain size on explosion.

Filling.—The charge loaded into the main container of the grenade.

Fragmentation.—The breaking up of a grenade into small pieces on explosion.

Detonator.—A small tube containing an explosive that can be fired by a blow or heat, the shock from which detonates the filling in the case of H.E. grenades, and opens the container in the case of smoke grenades.

Priming.—The operation of fitting a grenade with a detonator, &c. A grenade so fitted is said to be primed.

Premature.—A grenade which explodes earlier than is intended.

Blind.—A live grenade which, for some reason, has failed to explode when thrown or fired.

Discharger.—An attachment which, when fitted to the rifle, provides a means of discharging a grenade from the rifle with a specially filled grenade cartridge.

22. General

1. The principles governing the use of H.E. and smoke grenades in battle are laid down in Infantry Training, Vol. II, and Infantry Section Leading.

2. These principles are based on their characteristics, which are:—

- i. *Relatively short range.*—The H.E. grenade fired from a rifle has a maximum range of 325 yards, and the smoke grenade a maximum of 250 yards. The minimum in each case is 100 yards.
- ii. *High trajectory and steep angle of descent.*—This provides considerable searching power. An enemy behind bullet-proof cover can thus be driven into the open.
- iii. *Relatively heavy weight.*—The weight of the H.E. and smoke grenade is about one pound. This limits the number which can be carried by an individual or in regimental transport, and thereby restricts their use in battle.
- iv. *Large danger area.*—The probable danger area of a H.E. grenade may be taken to be twenty yards in all directions from the point of burst. The possibility, however, of large fragments having sufficient velocity to inflict wounds up to 100 yards, or more, must be considered, particularly

if the burst is on stony ground. It follows that throwing by hand is almost as dangerous to the thrower as to the enemy unless adequate cover exists, and that the use of cover by rifle bombers when firing the grenade should not be neglected.

- v. *Susceptibility to wind.*—The flight of grenades is considerably affected by the strength and direction of the wind. Corrections to allow for deflection will frequently be required when firing grenades, and in some cases it may even be necessary to increase or decrease range adjustment. Only experience will enable bombers to judge the necessary allowances for deflection or range adjustment.

3. *Employment of H.E. grenades.*—To render its killing power effective, the H.E. grenade must be burst on or close to the target. When fired from the discharger, this demands a high standard of training in range setting and maintenance of a constant angle of elevation as well as in judging the effect of wind. In view of the above factors, overhead fire with grenades entails considerable risk and should only be employed in case of necessity.

4. *Employment of smoke grenades.*—These are of value for blinding small enemy posts for a short period. Since only a limited number of such grenades is carried in the platoon their use with reference to the prevailing wind and the proposed direction of the movement to be made under cover of the screen must be carefully worked out (see Plates 7, 8 and 9). A mild wind and damp atmosphere give the best conditions.

PLATE 7

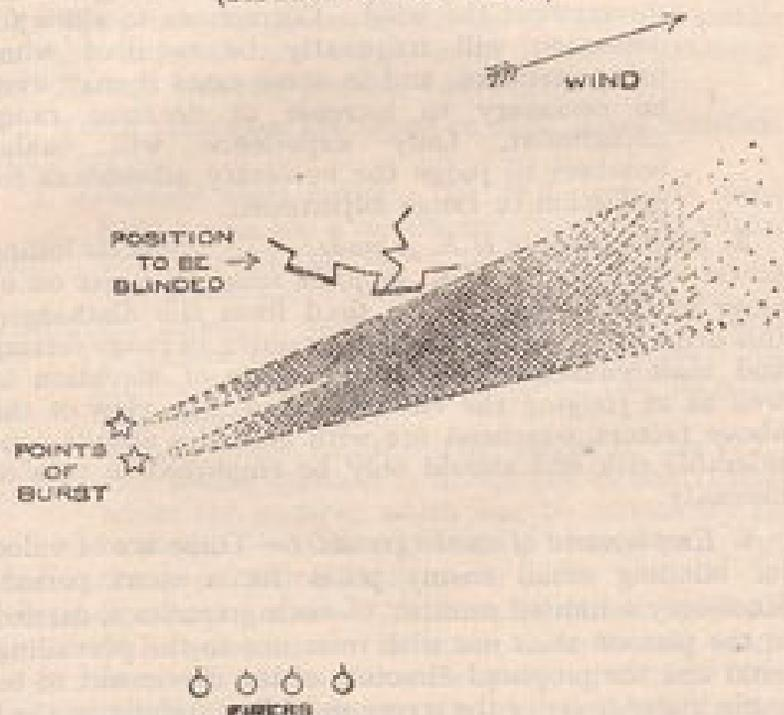
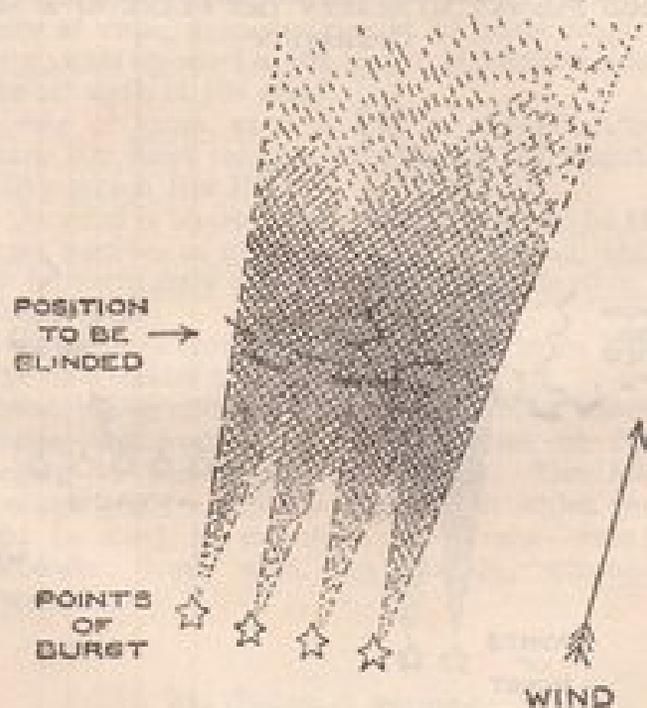
EMPLOYMENT OF SMOKE GRENADES
(SIDE OR CROSS WIND)

PLATE 8

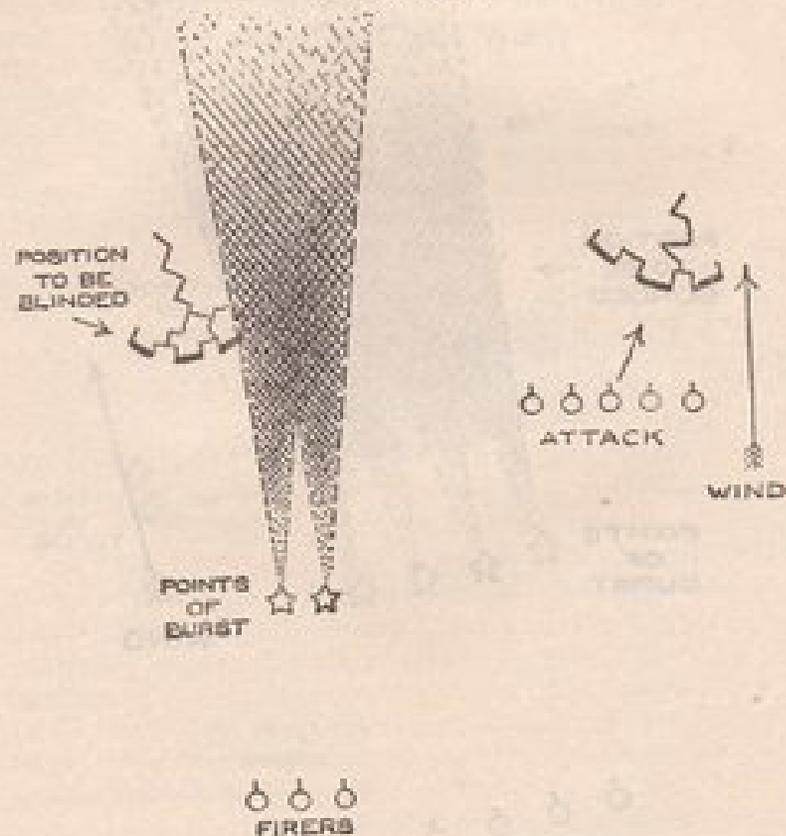
EMPLOYMENT OF SMOKE GRENADES
(WIND BLOWING DIRECTLY TOWARDS OBJECTIVE)

FIRERS

PLATE 9

EMPLOYMENT OF SMOKE GRENADES

A CLOUD FORMED TO SCREEN THE FLANK OF A SMALL OPERATION



Smoke grenades should seldom be thrown, and their use for overhead fire is inadvisable for the reasons given in para. 3, above.

As the smoke cloud does not reach its maximum density at once, grenades should be burst from ten to twenty yards up-wind of the area to be blinded, according to the strength of the wind.

A side or cross wind is the most favourable, and requires the least number of grenades to maintain an effective screen (see Plate 7).

If the wind is blowing towards the point to be blinded, a larger number of grenades will be required, and these must be accurately placed to form an effective screen (see Plate 8).

If the wind is blowing from the point to be blinded it will be inadvisable to use smoke.

The screen should be formed by a salvo of about three grenades, followed by single grenades at intervals according to atmospheric conditions. The following is a rough guide as to the intervals at which grenades should be fired to maintain the screen—mild wind, 15 seconds; fresh wind, ten seconds; strong wind, five seconds.

23. System of training

1. The methods of instruction in both H.E. and smoke grenades will adhere to the principles laid down in Vol. I, 1931, Sec. 3. Details as to grenade firing and throwing areas are as laid down in Vol. V, 1931, Chapter VII.

2. The sequence of instruction in lessons concerned with firing and throwing will follow that of the rifle. In lessons dealing with the construction and mechanism of grenades and the discharger, the "Question and Answer" method will be employed as far as possible.

3. Instructors will impress upon men the necessity for common sense, care, and some knowledge of the nature of grenades for those handling and using them, but will not lay too much stress upon the question of danger. To do so will cause lack of confidence and nervousness in handling grenades.

4. Once men have gained a reasonable working knowledge of the mechanism of grenades, the bulk of the time available for grenade training will be spent in firing practice, a small proportion only being allotted to throwing, particularly in the lying position.

5. In order to avoid unloading without firing, which is an action seldom likely to occur on service, practice in firing, other than dummy firing, will be carried out without loading with a grenade.

6. When an order is given to a rifle bomber to load, unless the type of grenade is specifically mentioned, H.E. will be used.

7. On service it is possible that a pause of several minutes will occur between the action of loading and the moment when fire is required. In order to prevent rifle bombers remaining in the strained position of the "aim," the command "Prepare to Fire" will be used by section commanders to indicate the moment when aim is to be taken.

8. All officers, warrant officers and non-commissioned officers whose duties in peace or war require them to deal with live grenade training must be able to assemble a fuze and detonator and prepare a demolition set (Sec. 29). They must know the safety precautions and rules laid down for the conduct of "live" practices and handling of "live" material.

Only an officer who has received instruction in the subject at a recognized school is permitted to conduct "live" practices or to destroy blinds.

Officers who are responsible for the care and storage of grenade stores must be acquainted with the rules laid down in Regulations for Magazines and Care of War Materiel.

9. The instructions relative to firing live grenades are the concern of officers and such N.C.Os. as may be selected to assist them. With the exception of the "Points before firing or throwing live grenades," they will not be taught to the men.

10. The sequence of subjects will be as follows:—

Characteristics and employment in the field—
brief explanation (Sec. 22).

Mechanism of H.E. Grenade.

„ „ the Discharger.

„ „ Smoke Grenades. (See Appendices
IV to VIII.)

Firing instruction (Sec. 24).

Throwing instruction (Sec. 25).

Practice in firing dummy grenades (Sec. 26).

„ „ throwing dummy grenades (Sec. 25).

Points before firing and throwing live grenade (Sec. 28).

Practice with live grenades (Sec. 28).

24. *Firing instruction*

LESSON 3.—THE LYING POSITION

1. *Preliminaries* :—

i. *Stores required*.—Rifles and bayonets, discharger, grenade, and one round dummy ballistite grenade cartridge for each man and for the instructor.

ii. Inspect rifles, dummies, ballistite grenade cartridge. Loosen slings. Carry out the *first safety precaution*. Extend squad. Instructor and squad fix bridges on rifles. Fix bayonets. Select grenade targets. "Load," "Rest." Instructor calls squad to his right side.

2. *Sequence of instruction*.

i. States object of firing instruction—to teach men how to fire H.E. and smoke grenades so that in war correct action will be instinctive. This lesson is how to fire grenades in the lying position.

ii. "Rifle Bomber—Range . . .—Load."

Instructor gives a complete demonstration, changing from rifleman to rifle bomber, naming phases as below :—

Closing cut-off.

Unloading ball.

Loading ballistite grenade cartridge.

Applying safety catch.

Fixing discharger.

Range setting.

Changing position.

Loading grenade.

Aiming and firing.

Reloading for missfire ballistite.

Unloading without firing. (In case of No. 36 Grenade, instructor adds: "Removing Grenade.")

Unfixing discharger.

Removing grenade.

Changing position.

Unloading ballistite grenade cartridge.

Reloading ball.

Instructor informs squad that this action will take place when a section commander is about to use H.E. or smoke grenades in battle. The lying position should be used for firing grenades whenever possible since it is the steadiest and the most comfortable for the firer, but the ground or cover will be the deciding factor in adopting a position.

Stage I. Unloading Ball Cartridge—Loading Ballistite Grenade Cartridge—Range Setting and Position for Firing

3. *Sequence of instruction*.

i. "Position." (Squad back to their places.)

ii. Instructor gives "Rifle Bomber—Range . . . —Position for Firing." Squad imitates him in :—

(a) *Changing to rifle bomber.*—Close the *cut-off*. If none, unload. *Safety catch* forward. Unload ball cartridge. Load with ballistite grenade cartridge. Apply *safety catch*. Draw back rifle under right armpit and unfix bayonet. Fix discharger. Set range, check final fitting of discharger. Roll on the right side, at the same time swinging the legs quickly round to the left. Right leg now straight and pointing to the target. Left knee bent and left foot close to the right knee, either inside or outside it as is most comfortable. Rifle reversed, *butt* on the ground, *barrel* at an angle of forty-five degrees. Right hand at the *small*, right elbow on the ground. Left hand near the *outer band*, clear of metal parts. Left forearm on left knee. Head well back over the heel of the *butt*.

(b) *Changing to rifleman.*—Change to position of rifleman, keeping the rifle under the right armpit. Unfix discharger. Fix bayonet and return rifle to loading position. Open *cut-off*. Unload ballistite grenade cartridge. Load with ball cartridge.

iii. Men practise individually. Instructor checks each man separately.

iv. Instructor assembles squad and, while it rests, gives reasons for *points to note*, viz. :—

<i>Points to note</i>	<i>Reasons</i>
(a) Closing cut-off.	To ensure ball cartridge ammunition is not fired in mistake for ballistite grenade cartridge.
(b) Position in which bayonet is unfixd, discharger fixed and range set.	To reduce movement in subsequent rifle bomber's position.
(c) Right leg pointing towards target.	To assist in getting direction.
(d) Left knee bent supporting the left forearm.	For steadiness.
(e) Right elbow on ground.	
(f) Rifle reversed.	To take shock of discharge evenly through rifle.
(g) Head well back over heel of butt.	To ensure accurate alignment on the point of aim.
(h) Rifle kept at an angle of 45 degrees.	All ranges marked on the gas port are based on this angle.

Instructor questions squad to ensure that these are understood.

v. Squad resumes original position and practises by word of command "Rifle Bomber—Range . . . —Position," followed by "Rifleman."

Stage II. Loading Position—Loading Grenade— Unloading without Firing

4. Sequence of instruction.

- i. Squad in lying position—rifleman.
- ii. Instructor orders "**Rifle Bomber—Range . . . —Position.**" Squad adopts "**Position for Firing.**"

iii. Squad imitates instructor in:—

(a) *Loading Position and Loading Grenade.*—Lower the body flat. Draw the rifle back over the right shoulder, keeping the action clear of the ground. Take out grenade with the left hand. *Unscrew the safety cap, keeping the fingers round the tape. Place the grenade in the discharger and press it home. Put the safety cap in a convenient place. Resume the "Position for Firing."*

(b) *Unloading without firing.*—Instructor explains that on service this will seldom occur, but may be required occasionally. Ensure that the safety catch is applied. Draw the rifle back to position for loading grenade. *Place the left hand over the opening of the discharger and unscrew the discharger with the right hand. Shake grenade out of discharger into the left hand, keeping the fingers round the tape. Replace the safety cap and return grenade to haversack.*

PLATE 10

FIRING—LYING. LOADING POSITION AND LOADING



Points to Note

1. Body flat on back.
2. Action clear of ground.
- *3. Securing tape in position.
4. Pressing grenade right home.

*For No. 36 Grenade.

3. i. Gas check screwed tight.
ii. Lever inside discharger.

Reasons

Concealment and convenience.
Keep it free from dirt.
Safety precaution.
To ensure maximum range.

To ensure correct direction in flight.
Safety precaution.

iv. Instructor explains that on service men would now change to riflemen, returning discharger to haversack. In this case he wants them to practise loading and unloading without delay. They will fix dischargers and return to the "Position for Firing."

v. Men practise loading and unloading individually. Instructor checks each man separately.

vi. Instructor assembles squad and, while it rests, gives reasons for *points to note* :—

For (a) : See Plate 10.

For (b) :—

<i>Points to note</i>	<i>Reasons</i>
1. Applying safety catch.	Safety precaution.
*2. Left hand over mouth of discharger while unscrewing.	To prevent grenade falling out.
†3. Keeping fingers round tape when shaking grenade out.	Safety precaution.
vii. Squad practises by word of command, e.g. "Load," followed by "Without Firing—Unload."	

Detail printed in italics in iii (a) and (b) above refers to No. 54 Grenade. Detail given in italics below refers to No. 36 Grenade. Instructors will substitute as required.

For No. 36 Grenade

* Grenade only raised high enough in discharger to allow of insertion of pin.

† Not applicable.

Loading

See that the gas check is tight by screwing it up; insert the grenade in the discharger, ensuring that the lever is inside the discharger. Hold the grenade with the left hand so that the pin can be withdrawn with the right hand. Place the forefinger of the right hand through the ring and withdraw the pin, which must be retained on the finger until the grenade has been fired. Press the grenade fully down.

Unloading without firing

With the left hand withdraw the grenade sufficiently far from the discharger for the pin to be put back. Hold the grenade in this position with the thumb and forefinger, and support the discharger with the remaining fingers. Replace the pin and unload the grenade from the discharger. Splay the pin on the edge of the discharger.

Stage III. Aiming and Firing*

5. *Sequence of instruction.*

i. Instructor and squad load (rifeman).

ii. "Rifle Bomber—Range . . .—Load." Change to rifle bomber and load.

iii. Squad imitates instructor.

"Prepare to Fire."—Remove the right hand from the *small*. Push the *safety catch* forward. Close the fist lightly,

* In this stage there will be no loading with grenades.

extend the forefinger and place it on the *trigger*, keeping the rest of the hand clear of the rifle. With the head well back and the rifle held at an angle of 45 degrees, align the rifle in the direction of the target. On the command "Fire" take the first pressure and, as soon as the alignment is correct, take the second pressure. If the order is given to fire another grenade, reverse the rifle, load with ballistite grenade cartridge, apply the *safety catch* and load another grenade as before.

During imitation instructor emphasizes *points to note* (see vi, below).

- iv. Instructor explains that on service when the required number of grenades have been fired, men would get an order to change to rifleman. In this case, as he wants them to practise "Aiming and Firing," this order will not be given until after men have practised.
- v. Men practise individually. Instructor checks each man separately.
- vi. Instructor assembles squad and, while it rests, gives reasons for *points to note* (Plate 11). Instructor then explains that, if ballistite grenade cartridge missfires, the firer will reverse the rifle, unload the round, load again with a fresh round, apply the *safety catch*, reverse the rifle, aim, and without waiting for any further order, will fire.

PLATE 11

FIRING—LYING. PREPARE TO FIRE AND FIRING POSITION



- | <i>Points to note</i> | <i>Reasons</i> |
|---|---|
| 1. Right leg pointing towards target. | To assist in getting direction. |
| 2. Left knee bent, supporting the left forearm. | } For steadiness. |
| 3. Right elbow on ground. | |
| 4. Except for trigger finger, hands clear of all metal parts. | To prevent damage to the hands on discharge of the grenade. |
| 5. Rifle reversed. | To take shock of discharge evenly throughout rifle. |
| 6. Head well back over heel of butt. | } To ensure accurate alignment on the point of aim. |
| 7. Rifle aligned in the direction of the target by having the point of aim, the axis of the rifle barrel and the firer's eye all in one vertical plane. | |
| 8. Rifle kept at an angle of 45 degrees. | All ranges marked on the gas port are based on this angle. |

vii. Further practice in aiming and firing by word of command, *e.g.* : "Range . . .—Load—Prepare to Fire—Fire." Instructor will introduce the following variations :—

(a) Missfire ballistite grenade cartridge—occasionally only.

(b) Firing smoke grenade instead of H.E.

viii. Instructor orders "Rifleman." Then, to complete the Lesson, further practice by word of command, *e.g.* : "Rifle Bomber—Range . . .—Load—Prepare to Fire—Fire," followed by the command "Rifleman."

LESSON 4.—THE KNEELING POSITION

1. *Stores required and Preliminaries* as for Lesson 3, except command is "Kneeling Load"—"Order Arms"—"Ground Arms."

2. *Sequence of instruction.*

- i. Instructor states lesson is how to fire grenades in the kneeling position.
- ii. Instructor explains that, on the order to change from rifleman kneeling to rifle bomber, the *sequence* of actions is the same as in the lying position, but there are small differences in the way in which they are carried out.
- iii. Instructor gives complete demonstration as for lying position, naming only the following four phases :—

Changing position.

Reloading missfire ballistite grenade cartridge.

Unloading without firing.

Changing to rifleman.

He then informs squad that this position will be used when the ground or cover prevents the firer seeing the target in the lying position.

Stage I. Unloading Ball Cartridge—Loading Ballistite Grenade Cartridge—Range Setting—and Position for Firing

3. *Sequence of instruction.*

- i. Instructor gives "Rifle Bomber—Range . . . —Position for Firing." Squad imitates instructor—*Cut-off*, unloading ball cartridge, loading ballistite grenade cartridge, *safety catch*. Bring right knee close to left leg. Draw rifle back under right armpit, pressing it close to the body with the right arm. Unfix bayonet. Fix discharger. Set range, check final fitting. Rifle reversed, *butt* on the ground and well forward, *barrel* at an angle of 45 degrees. Right hand at the *small*, left hand near the outer band, clear of metal parts; left arm on the left knee. Head well over the *butt*.

Changing to rifleman : pull the rifle back under right armpit, unfix discharger, fix bayonet. Adopt correct position as rifleman, unload ballistite grenade cartridge. Load ball cartridge.

During imitation instructor emphasizes *points to note* (see sub-para. iii, below).

- ii. Men practise individually. Instructor checks each man separately.
- iii. Instructor assembles squad and, while it rests, gives reasons for *points to note* where necessary, and questions squad to see that these are understood.

*Points to note**Reasons*

- | | |
|-----------------------------------|---|
| (a) Closing cut-off. | To ensure ball cartridge ammunition is not fired in mistake for ballistite grenade cartridge. |
| (b) Right knee close to left leg. | For convenience in aligning the rifle. |
| (c) Rifle reversed. | To take shock of discharge evenly throughout the rifle. |
| (d) Butt well forward. | To ensure that the bolt lever does not strike the right leg when firing. |

- iv. Further practice by word of command.

Stage II. Loading Position—Loading Grenade—Unloading without Firing

t. Sequence of instruction.

- i. Instructor explains that to load the grenade and unload without firing are the same as in the lying position.
- ii. Squad practises by word of command.
- iii. Squad rests and is questioned on reasons for *points to note*. For "Loading," see Plate 12;

PLATE 12

FIRING—KNEELING. LOADING POSITION AND LOADING

*Points to Note**Reasons*

- | | |
|---------------------------------|--|
| 1. Position of rifle. | To facilitate loading grenade. |
| *2. Securing tape in position. | Safety precaution. |
| 3. Pressing grenade right home. | To ensure maximum range. |
| *For No. 36 Grenade. | |
| 2. i. Gas check screwed tight. | To ensure correct direction in flight. |
| ii. Lever inside discharger. | Safety precaution. |

for "Unloading without Firing" as in Lesson 3, Stage II.

iv. Further practice.

Stage III. Aiming and Firing

5. Sequence of instruction.

- i. Instructor explains that aiming and firing are the same as in the lying position.
- ii. Squad practises by word of command.
- iii. Squad rests and is questioned on reasons for *points to note* (see Plate 13, Figs. 1 and 2).
- iv. Further practice.

25. Throwing instruction

General

1. Grenades over one pound in weight cannot be thrown—in the strict sense of the word—by the average man, whilst their characteristics require them to be thrown at a high angle. It will be found, therefore, that the best method of delivering the grenade by hand is by an overarm swing, similar to "bowling" in cricket.

2. In the succeeding paragraphs and in the "Lessons," the words "right" or "left" in brackets, following "left" or "right," refer to a left-handed thrower.

3. Accuracy is of more importance than the distance of a throw. Any tendency, therefore, on the part of men to see how far they can throw the grenade, irrespective of accuracy, will be checked at once.

4. Accuracy is obtained by—

- i. Keeping the eyes on, or on the line of, the target.

PLATE 13

FIRING—KNEELING. PREPARE TO FIRE AND FIRING POSITION



FIG. 1
SIDE VIEW

Points to note

1. Except for trigger finger, hands clear of all metal parts.
2. Rifle kept at an angle of 45 degrees.
3. Head well back over heel of butt.
4. Alignment of rifle.

FIG. 2
FRONT VIEW

Reasons

1. To prevent damage to the hands on discharge of the grenade.
2. All ranges marked on the gas port are based on this angle.
3. To ensure accurate alignment on the point of aim. To avoid muzzle blast from ballistite.
4. To ensure accurate alignment on the point of aim.

ii. Correct pointing of the left (right) shoulder relative to the target. Men who have a consistent fault in throwing to one side of the point of aim must be taught to counteract this by pointing the shoulder a corresponding distance to the other side of the target.

iii. Keeping the right (left) arm in the forward action as upright as possible. This will also minimize any tendency to throw without sufficient elevation.

5. Distance depends mainly on a natural swing which is free and vigorous. Men will be allowed to throw in the way which is natural to them so long as they apply the points mentioned above in para. 4 to their swing. **Apart from the initial lesson anything which tends to drill movements in throwing will be avoided.**

6. The following precautions will be taken when throwing dummy grenades :—

i. Only one man will throw at a time, except when imitating instructor in first throw, when all men throw together.

ii. No man is to throw without a direct order.

iii. Grenades will never be thrown from man to man.

iv. No man will attempt to catch a grenade.

v. When throwing from the various distance circles over the high wire, the throwers should be arranged in echelon, so that those behind do not endanger those in front.

vi. No man will pick up a grenade which has been thrown until ordered to do so.

7. In the early stages of instruction in throwing,

instructors will detail a member of the squad to stand directly behind the target so that he can observe the strike of the grenades and call for necessary corrections to bring the next throw on to the target.

Corrections will be to the nearest yard. The words "Up" and "Down" will be used in the case of grenades falling short of or beyond the target respectively. "Left" and "Right" for lateral errors, *e.g.* a grenade falls two yards short and one yard right of the target. Correction will be "Up two, left one."

It is essential, however, for men to become capable of observing and making corrections themselves. This training will be introduced into practice as soon as possible.

8. At first men should be allowed to throw in shirt sleeves, gradually working up to the conditions of throwing when wearing marching order and steel helmets.

9. When men have acquired a satisfactory swing and reasonable standard of accuracy, practice with dummy grenades should be carried out as below :—

i. *Standing Position* :—

(a) High Wire, Vol. V,
1931, Plate 41 ... To teach men to throw high.

(b) Cage, Vol. V, 1931,
Plate 43 ... To combine accuracy,
length and direction with
a high throw from cover.

ii. *Lying Position* :—

Using the cages as for standing. Thrower will be behind cover which will have been erected five yards in front of the throwing cage.

LESSON 5.—STANDING POSITION

1. Preliminaries.

- i. Stores required.—Not less than two dummy grenades for each man.
- ii. Squad in shirt sleeves. Instructor issues grenades and squad carries out *the first safety precaution* and places grenades on the ground.
- iii. Instructor mentions precautions as laid down in Sec. 25, 6.

2. Sequence of training.

- i. Instructor states the lesson is how to *throw* grenades in the standing position.
- ii. Explains that this grenade is too heavy for a man to *throw*—in a strict sense of the word—and an overarm action like a bowler (demonstrate) is used.
- iii. Instructor, facing same direction as the squad and opposite left-hand man, gives complete demonstration, naming phases:—

Ready position,

Removing safety cap,

Throwing grenades.

He then informs squad that occasions may arise on service when throwing of grenades is necessary.

- iv. Squad imitates instructor. *Pick up a grenade. Place it in the palm of the right (left) hand. Grip it firmly, keeping the forefinger and thumb round the base of the safety cap. Place the forefinger*

and thumb of the other hand over the top of the safety cap—hands with knuckles uppermost and close to the waist. Face the target, turn to the right and balance the body by carrying off the left (right) foot towards the target.

Instructor informs squad this is the "Ready Position," and will be adopted whenever the command "Ready" is given. *By a turn of the hands remove the safety cap, taking care that the forefinger and thumb of the right (left) hand keep the tape on the grenade. The safety cap will be kept in the left (right) hand until the grenade has been thrown. Slightly bend the knees. Fix the eyes on, or in the direction of the target, keeping the left (right) shoulder pointing at the target. Swing back as far as possible, allowing the left (right) arm (and foot, if necessary) to come up naturally. Without a pause swing quickly forward, keeping the right (left) arm upright and deliver the grenade.*

During imitation instructor emphasizes *points to note* (see sub-para. vi, below).

- v. Without using grenades, men practise individually throwing action only whilst instructor supervises, each man in turn throwing two grenades.
- vi. Instructor assembles squad and, while it rests, gives reasons for *points to note* and questions squad to ensure reasons are understood.

<i>Points to note</i>	<i>Reasons</i>
(a) Eyes on, or in the direction of the target throughout the throw	} To assist accuracy.
(b) Left (right) shoulder pointing at the target until the grenade leaves the hand.	
(c) Muscles not rigid and a free easy swing without pauses.	To assist in making a long throw (if required).
(d) Right (left) arm as up-right as possible.	To assist accuracy and in getting high angle of throw.

vii. Further practice as in v, but dummy grenades will be pooled and each man will throw four or five in succession.

Detail printed in italics above refers to No. 54 grenade. Detail in italics below refers to No. 36 grenade. Instructor will substitute as required.

Pick up a grenade. Hold it in the right (left) hand base downwards, the lever under the base of the fingers, thumb just below the filling screw, gripping it firmly. Place the first or second finger of the left (right) hand through the ring of the safety pin, hands with knuckles uppermost and close to the waist. Face the target, turn to the right and balance the body by carrying off the left (right) foot towards the target. Keeping the left (right) arm still and close to the body, withdraw the pin by thrusting the right (left) hand downwards and back-

wards; glance at the shoulders of the grenade to see that the whole pin has been drawn out. Keep the pin until the grenade has been thrown.

LESSON 6.—LYING POSITION

1. Preliminaries.

Stores required, as in Lesson 5.

2. Sequence of instruction.

- i. Instructor states lesson is how to throw the grenade in the lying position.
- ii. Instructor adopts lying position so that squad can see his right (left) side, and gives complete demonstration, naming phases:—

Ready position,
Removing safety cap (or pin),
Throwing grenade.

He then informs squad that it will not always be possible to stand up to throw, or even to kneel, so the throw must be done from the lying position.

iii. Squad imitates instructor.

Lie face downwards directly towards the target. Hold the grenade as in the standing position, both hands close under the chin. Elbows outwards. Remove the *cap* (or *pin*) as before. Place the hands in a natural position for pressing up, keeping the *cap* (or *pin*) in the left hand. Press quickly up on both knees. Keeping the left (right) knee on the ground, swing the body quickly back,

allowing the left (right) arm and the right (left) knee to come up naturally. Keeping the eyes and left (right) shoulder on the line of the target, swing forward, right (left) arm as upright as possible, and deliver the grenade. Quickly lie down.

Points to note are the same as for the standing position.

- iv. Men pick up grenades and practise individually, as in Lesson 5.
- v. Instructor assembles squad and, while it rests, questions on reasons for *points to note*.
- vi. Further practice, pooling grenades, as in Lesson 5.

26. Firing dummy grenades

1. *The range*.—The live firing range will never be used for dummy firing. The ground chosen should preferably be soft, in order to avoid breakages. There should be no long grass, &c., near the targets, or difficulty will be experienced in finding the grenades and time will be wasted. The size of the ground should, if possible, admit of targets being placed up to the full range of the weapon and enable a number of sections to work at the same time. Rifle bombers must be trained to make use of cover at all times. Firing points and targets will be numbered.

On hard ground it is advisable to have either a partially filled or a folded sandbag under the heel of the butt to avoid damage to the rifle.

2. *Targets*.—Targets should represent sections of trench, shell-holes, &c., and not individual men. On a

permanent range these may be actually dug in. Where digging cannot take place they should be outlined with sandbags.

3. Range discipline.

- i. Only the instructor and the detail firing will be on the firing-point.
- ii. The next detail to fire will wait about five yards in rear of the firing-point.
- iii. The remainder of the squad will be not less than ten yards in rear.
- iv. No man will fire without a direct order.

4. Method of conducting practice.

- i. Sections will be formed up in rear of the firing-point, the order of firing given out and details ordered to assume the positions referred to in para. 3, above.
- ii. A rifle fitted with discharger, a supply of grenades and ballistite grenade cartridge will be at each firing-point.
- iii. Each man will load and fire on the order of his immediate commander.
- iv. (a) During firing the instructor will ascertain from the firer the correction to be made, if any, after firing each grenade.
(b) No correction will be made unless the instructor is satisfied that the angle of the rifle was 45 degrees.
(c) In this connection, the size of the area at the target that, under normal circumstances, will include the correctly fired grenades, must be considered, as no correction would be necessary for grenades

falling within this area. The following are the approximate sizes of areas of ground at the target which should contain grenades fired with the correct range adjustment and angle of rifle, in still air:—

Range	AREA	
	Length yds.	Width yds.
300 yds. ...	20	10
200 yds. ...	15	5
100 yds. ...	10	2

- v. On the command "Unload," the firer will unload his rifle, close the gas port, ground arms, and stand up.
- vi. The number of grenades which can be fired by each detail will depend upon circumstances, but two should be considered the minimum. Details may repeat the practice as often as time permits. Recovery of grenades will only be carried out by order of the senior officer or N.C.O. present.
- vii. Instructors on the firing-points will discuss the question of wind allowance, but, so far as possible, they will get the man to make his own estimate.
- viii. Apart from the wind, errors in direction may be due to two causes:—
 - (a) Faulty alignment—most common in the kneeling position, the tendency being to throw shots to the left.
 - (b) Flinching—the tendency being to throw shots to the right.

27. Tests of elementary training

Oral Tests

A total of four questions, covering the subjects stated below, will be asked.

Standard to pass.—Satisfactory knowledge in three out of four:—

1. The mechanism and action of each type of grenade in use.
2. The mechanism, fixing, care and cleaning of the discharger and bridge.

Inspection Test

Inspection and preparation for use of grenades and detonators.—Each man will be required to carry out the test with dummy material and at the same time describe what he is doing.

Standard Tests

1. *Changing from rifleman to rifle bomber and vice versa.*
 - i. *Lying position.*
 - (a) Changing to rifle bomber ... 50 seconds *
 - (b) Changing from rifle bomber 30 seconds *
 - ii. *Kneeling position.*
 - (a) Changing to rifle bomber ... 50 seconds *
 - (b) Changing from rifle bomber 30 seconds *

Words of command will be—"Rifle Bomber—Range . . ." or *vice versa*.

* In the case of the 2½-inch discharger the times will be 40 seconds and 20 seconds respectively.

The time will be taken from the moment of giving the range until the change is completed.

Standard to pass.—Position in each case must be correct after change.

2. *Firing.*—Each man must fire three grenades out of five into a circle 40 feet in diameter, at a range of 150 yards.

Target, a shell-hole in the centre of the circle.

Firing position, according to the ground.

3. *Throwing.*—This test will be carried out on the "Cage test" ground (*see* Vol. V, 1931, Plate 43) in the standing position; the number of grenades will be fifteen.

- i. The men will throw first at the centre cage until he has thrown three grenades into it.
- ii. He will then throw at the right-hand cage until he has thrown three grenades into this also.
- iii. Any balance of grenades will be thrown at the left-hand cage.

Standard to pass :—

Three grenades thrown into the centre and right-hand cages.

Two grenades thrown into the left-hand cage.

28. *Training with live grenades*

General points before Firing and Throwing Live Grenades

1. Live grenades must be carefully inspected as a preliminary to their preparation for use. This inspection is for the purpose of discovering :—

- i. Defects which might lead to prematures.
- ii. Defects which might cause blinds or weak explosions.

For other instructions, *see* Appendix relating to grenade in question.

2. Inspection should always be carried out according to a definite plan in order to prevent points being overlooked. The detail of inspection will depend upon the type of grenade.

3. Grenades and their burster sets or detonators will never be inspected together; the inspection of the grenades should be completed first, they will then be repacked and placed on one side. Inspection of the *burster sets* or *detonators* follows.

4. *The first safety precaution.*—Whenever a grenade is first handled the plug or other device will always be removed at once to ascertain whether it is primed or not.

General instructions regarding the Firing and Throwing of Live H.E. Grenades

5. Although the use of grenades can be taught in all its branches by employing dummy material only—the dummy grenade behaves in exactly the same way as a live one except that it does not explode—the training of a bomber cannot be considered complete until he has thrown or fired live grenades.

6. Live practices are simply to give confidence to the man in handling a weapon which is, wrongly, supposed to be very dangerous. With present-day equipment

accidents can generally be traced to one of four main causes:—

- i. Ignorance.
- ii. Negligence.
- iii. Deliberate mishandling.
- iv. Fright.

The first three can be excluded by training and supervision; the last can be overcome by live practice. Confidence comes quickly after firing or throwing even one grenade. Should the allowance of grenades permit, two should be thrown in addition to those fired from the discharger.

7. *The range.*—The plan of the danger area of the live H.E. bombing range is shown in Vol. V, 1931, Plate 44. The plan of suitable live throwing and firing trenches is shown in Vol. V, 1931, Plate 45. The danger area must be clearly marked out by red danger flags and look-out men posted whenever the range is in use. A minimum distance of 200 yards must be allowed in all directions from every possible point of burst.

8. *Targets.*—These should be similar to those used for dummy firing, *i.e.* shallow trenches and shell-holes. Each may be marked by a number, preferably of metal, placed near it to facilitate indication. One target for throwing will be placed in front of each throwing bay. For firing, a single set of targets, at distances intermediate between the minimum and maximum ranges of the weapon, will suffice for all firing bays.

9. *Safety precautions (see Vol. V, 1931, Plate 45).*—The following precautions will be strictly observed:—

- i. Before a live practice begins all danger flags must be raised, look-out men posted and the whole of the ground, including the danger area, ascertained to be clear of persons and live-stock.
- ii. A medical orderly provided with all first-aid appliances should be in attendance on the range under suitable cover, generally in one of the splinter-proof shelters. If a medical orderly is not available, a box containing tourniquet, bandages, iodine, &c., must be provided and kept in the observation post throughout the practice. In any case, the medical officer in charge of the troops concerned will be informed that live firing is to take place.
- iii. Every person on the bombing range must wear a steel helmet.
- iv. Smoking is absolutely forbidden on the range, and at any time when live grenades, *detonators*, &c., are being handled or carried.
- v. A red danger flag will be kept on the control post during practice. This will be lowered as a signal that practice is about to begin, the officer having first satisfied himself that danger flags and look-out men are in position and that the range is clear. No person may enter the danger area unless the flag on the control post is raised.
- vi. A qualified officer will always be in charge and will control the practice from the control post.

- vii. A N.C.O., who must be a trained bomber, will be on duty in each *priming bay* and in each *throwing or firing bay*.
- viii. Not more than one person in addition to the N.C.O. on duty will be in any *priming, throwing or firing bay* at any time.
- ix. Every one, except the Officer in the Control Post, the N.C.Os. on duty in the *priming, throwing or firing bays*, and the men actually throwing, priming or firing, will be under cover in the splinter-proof shelters.
- x. No grenade will be primed until the man enters the *priming bay* preparatory to throwing or firing. To ensure that this rule is obeyed, the box containing the *burstler sets or detonators* will be in the possession of the N.C.O. on duty in the *priming bay*, who will issue the number required to each man in turn as he enters and will personally superintend the operation of priming.
- xi. No grenade will be loaded, and no man will fire or throw without the direct individual order of the officer in charge.
- xii. Any order to take cover must be instantly obeyed.
- xiii. To eliminate any possibility of prematures, all the points laid down for the inspection and preparation of grenades, *burstler sets* and *detonators*, &c., will be strictly observed (see Appendix for grenade in question).
- xiv. Every blind will be accounted for and destroyed before leaving the range.

- xv. The "demolition" box must always be on the range during practice.
 - xvi. On hard ground it is advisable to have either a partially filled or folded sandbag under the heel of the butt to avoid damage to the rifle.
 - xvii. It is the duty of the officer conducting live practices to foresee the possible incidents that might occur through nervousness, or failure in the material being used, which are likely to endanger those taking part. He should instruct N.C.Os. and men in the immediate action to be followed. See special instructions in the Appendix for the grenade in question.
10. *Method of conducting practice.*
- i. Sections will be told off into details, the requisite number of unprimed grenades will be issued to each man, and they will then be marched into their respective splinter-proof shelters.
 - ii. N.C.Os. for duty will then take their places; those detailed for the *priming bays* will have with them the necessary number of *burstler sets or detonators* in their boxes.
 - iii. The officer in charge will take his place in the control post; he will have with him the demolition box and any spare grenades there may be. Having ascertained that all safety regulations have been complied with, he will lower the control post flag and order the first detail into the *priming bay*.
 - iv. The first detail will prime their grenades and pass on to the *throwing or firing bays*, as the

case may be; the second detail will at once take the place of the first in the *priming bay*.

- v. *Only those grenades will be primed which are to be used before returning to the splinter-proof shelter; no man will return to the splinter-proof shelter with a primed grenade. Should the practice be cancelled for any reason before the number of primed grenades has been used, the N.C.Os. in throwing or priming bays will see—failing orders to this effect—that the unused grenades are unprimed; they will retain the burster sets or detonators. This does not refer to the stopping of a practice due to a blind.*

- vi. When a firing practice is being carried out the procedure will be as follows:—

<i>Command</i>	<i>Action</i>
“Range . . . Target—No. 1 Load.” (The number means No. of bay.)	No. 1 loads ballistite grenade cartridge, applies safety catch, sets range, loads grenade. As soon as he is ready, the N.C.O. will hold up his hand.
“No. 1—Prepare to Fire.”	No. 1 pushes forward safety catch and aims.
“No. 1—Fire.”	No. 1 fires, observes flight of his grenade and takes cover.

Whenever the command “Fire” is given, the occupants in all other bays will take cover. The officer in the control post will observe the actions of the firer, the

flight of the grenade, and that every one has taken cover. He will then take cover himself. After the explosion he will continue as follows:—

Command—“Range . . . Target—No. 2—Load.”

If there are more than two bays, the procedure will be the same until all have fired one grenade. No. 1 will then fire his second grenade, the same sequence being observed until all grenades have been fired by the detail.

<i>Command</i>	<i>Action</i>
“Detail—Change.”	First detail moves to its <i>splinter-proof shelters</i> . Second detail replaces first in the <i>firing bay</i> , and the third moves from <i>splinter-proof shelter</i> to <i>priming bay</i> .

- vii. When a throwing practice is being carried out, the preliminaries, safety precautions, and procedure will be as for “Firing,” with the exception that the following words of command will be used:—

<i>Command</i>	<i>Action</i>
“No. 1—Ready.”	No. 1 adopts the “Ready” position. The N.C.O. will hold up his hand as a signal to the officer when this has been done.
“No. 1—Throw.”	No. 1 prepares the grenade for throwing; throws, observes flight of grenade and takes cover.

Whenever the command “Throw” is given, the occupants of all other bays will take cover. The officer will act as in firing practice.

11. *Action in case of blinds.*—Should a blind occur, every one will remain under cover until further orders. After an interval of one minute in the case of percussion grenades, and five minutes in the case of time-fuze grenades, the officer in charge will proceed alone to destroy the grenade where it lies (*see* Sec. 29, 12).

12. For the purpose of recording and reporting failures and defects, the officer in charge will observe any irregularities in the performance of the grenades.

29. *Preparation of demolition sets and the destruction of blinds*

1. *Stores required* :—

Demolition box containing :

1 box Fuze, Safety, No. 11.

1 box No. 8, Mark VII, detonators.

1 cylinder, 1 oz. gun-cotton primers.

Luting.

1 rectifier.

1 pair pliers.

A knife and matches will be required. The latter will not be carried in the demolition box.

2. *Fuzes.*—In firing charges of explosives, it is necessary for the man who is firing the charge to be able to do so from a safe distance, or to be given time to take cover before the explosion occurs.

3. For firing charges at a distance, "instantaneous" fuze is employed; this burns at the rate of about 90 feet in one second, and the length used depends upon the safety distance required.

4. **Instantaneous Fuze** is never used in grenade work, even for the destruction of blinds, but it is necessary for every one who may have to destroy blinds to be familiar with its appearance and characteristics in order to be able to distinguish it. The types of instantaneous fuze in use are as follows :—

Mark IV.—Coloured red. The exterior consists of a waterproof tape covering.

Mark V.—Coloured orange, and is ribbed on the outside by means of crossed threads wound round it to enable it to be distinguished by touch in the dark.

Fuze, instantaneous, detonating.—Used for mining and demolition purposes, and is contained in tin or lead tubing.

5. **Safety Fuze** is used in grenade work in connection with the destruction of blinds, and also forms part of the firing mechanism of many grenades themselves. It is slow burning, and is used in comparatively short lengths. The time that elapses between the lighting of the fuze and the explosion allows the firer to get under cover.

6. **Fuze, Safety, No. 11.**—This fuze is used for demolition purposes and burns at the rate of 36 inches in approximately 90 seconds (1 inch in $2\frac{1}{2}$ seconds). There may be a variation of 15 seconds, less or more, in every 36 inches. It consists of a core of finely ground gunpowder surrounded by strands of hemp or jute covered by a layer of gutta percha and finally by a covering of black waterproof tape. It is packed in tins containing rolls of 48 feet. The rate of burning is marked on the label on the lid of the tin.

7. Fuze precautions :—

- i. When taking a new box into use the rate of burning should be tested by burning a measured length—say, 12 inches—and noting the time taken.
- ii. Always unroll the *fuze*; attempts to straighten out a coil by pulling the loose end will result in the formation of kinks and breakage of the powder trail; this may cause failure in use. The end of the *fuze* which is to be lighted must be cut on the slant so as to expose a large area of the powder trail.
- iii. *Lighting the fuze.*—*Fuze* may be lighted easily by means of a *port fire* or *vesuvian* specially made for this purpose, but generally matches only will be available.
- iv. *Fuze* cannot usually be lighted by applying the flame of an ordinary match; the flame temperature is too low and only results in melting the gutta percha in the *fuze*, which then covers the surface of the powder trail and lighting becomes impossible.
- v. The method to be adopted, therefore, is to hold the match against the *fuze*, so that its head is in direct contact with the end of the powder trail, then to rub the prepared surface of the match-box on the head of the match; the burst of flame in close contact with the powder causes it to ignite at once.
- vi. *Safety fuze* cannot be extinguished even by placing it under water.

8. Detonators :—

- i. There is one particular property of high explosives which distinguishes them from gunpowder and certain other low explosives; they can be detonated. Detonation is very much more violent than ordinary explosion and, therefore, the effect produced by a given quantity of explosive is very much greater. Detonation, however, cannot generally be caused by lighting a high explosive in the ordinary way; it is necessary to initiate the detonation in some way, and for this purpose a device called a *detonator* is employed. Its characteristics are that it can be detonated by a blow (as in a percussion cap), by friction, or by a flame. A *detonator* can, therefore, be set off by the flame from a *safety fuze*, and if placed in contact with a high explosive charge will cause it to detonate.
- ii. The *detonator*, as used in bombing, consists of a small copper tube closed at one end and partly filled with a small quantity of very sensitive and powerful explosive, much too sensitive to be used in large quantities. This explosive is generally fulminate of mercury, or some mixture of this substance. These *detonators* are classified as "Service" or "Commercial," and their size is expressed by a number.
- iii. An example of a Service *detonator* is the No. 8, Mark VII. These are used in bombing, for the destruction of blinds. The No. 8, Mark VII,

detonator is painted red and has a small label affixed to it bearing its designation: they are packed in red tin boxes containing 25, each in a separate recess.

9. Detonator precautions.—

- i. In view of the sensitiveness of the explosive contained in *detonators*, they must be handled with great care. They must not be struck, crushed or bent, nor subjected to heat or friction. No attempt will be made to interfere with the substance contained in them.
- ii. They are quickly affected by damp, and should always be kept closed in their boxes.
- iii. When stored, the provisions of the Regulations for the Care and Storage of War Materiel will be strictly observed.

10. Assembling fuzes and detonators.

- i. Cut off the length of *fuze* required; the end which is to be lighted being cut on the slant and the other end square.
- ii. Remove any loose threads which may be sticking to the outside of the *fuze* where it is to be inserted into the *detonator*,
- iii. Measure the distance from the mouth of the *detonator* to the surface of the *fulminate* by inserting a blade of grass, and mark off on the *fuze* a length $\frac{1}{4}$ inch less than this.
- iv. Smooth down the end of the *fuze* with the fingers, so that it will go easily into the *detonator*, and

insert it gently up to the mark previously made. Do not use a screwing motion in doing this, as the friction which might possibly be caused would be dangerous.

- v. The *fuze* must now be fixed to the *detonator*. For this purpose *pliers* are used.

Place the *pliers* over the *fuze* and slide them down until the jaws are just over the mouth of the *detonator*. Never put the *pliers* over the filed end of the *detonator*. Crimp the mouth of the *detonator* so that the *fuze* is firmly gripped. A *detonator* once crimped to a *fuze* will never be pulled off. Should it be necessary to remove it, the *fuze* must be cut.

- vi. *Fuze* and *detonator* are then ready for use, but to avoid any possibility of flame or water penetrating between the *fuze* and the *detonator*, the joint is luted with luting, or mud if no luting is available. Only a very small quantity of luting should be used, just sufficient to fill any small crevices there may be.

11. Assembling a demolition set.—A suitable length of *safety fuze* will be fitted to a No. 8, Mk. VII, *detonator* (8 inches of No. 11 *fuze* gives about 20 seconds). A gun-cotton *primer* will be prepared for the reception of the *detonator* by easing out the central hole with the wooden *rectifier*; this operation must be carried out gently, so as to minimize friction. No metal instrument will ever be used for this purpose. The *detonator* will then be fitted into the *primer*; the *detonator* must never be

forced in; if the hole in the *primer* is not large enough it must be further enlarged with the *rectifier*. To prevent the *detonator* coming out, a little luting or mud should be used to lute the joint.

When preparing the charge the officer may be assisted by one other person only; with this exception every one will remain under cover.

12. To destroy a blind.—Place the above-mentioned demolition set so that the primer actually touches the grenade. Having ascertained that all other persons are under cover, the officer will light the fuze and himself take cover. After the explosion he will examine the place to make certain that the grenade has been demolished.

Whilst engaged in placing, or lighting, the demolition set against a percussion grenade, the officer should be careful to secure his steel helmet or anything likely to fall off and disturb the grenade.

30. Reporting failures and defects

(See Appendices concerned)

1. All cases of failures and defects in material will be recorded, and if it is considered that they are due to faults in design or manufacture, a report will be made in the prescribed manner.

2. Such cases would be:—

- i. Defects noted during the inspection of grenades and *burstier sets* or *detonators*.
- ii. Failure of any portion of the *burstier sets* or *detonators*, e.g. *cap*, *fuze*, *detonator*.

iii. Failure of the grenade to detonate although the *burstier set* has functioned perfectly. When this failure occurs, the grenade is burst into two or three large pieces by the *detonator*, and if examined, some of the explosive will usually be found; very little noise is made by a grenade bursting in this way.

iv. Defects in ballistite grenade cartridge, *i.e.* misfires, weak explosion resulting in grenades going short or even remaining in *discharger*, blowbacks, split *cases*, &c.

v. Any defects found in rifles or *dischargers* after use.

3. In making such records or reports the following information will be obtained, if possible:—

- i. Designation of article; number, mark, &c.
- ii. Dates of manufacture and packing.
- iii. Name of manufacturer, packer's notes, &c.
- iv. Any markings on the article in question, such as base markings in the case of cartridges.

4. In the case of the failures mentioned in para. 2, iv, the number of the rifle and of the *discharger* will also be recorded. Whenever the defective article itself can be produced, it should be forwarded with the report.

31. Precautions in handling live material

(For precautions during live practice, see Sec. 28, 5)

1. Live material will not be used unless a qualified officer is in charge. The use of improvised grenades of a dangerous nature, and the carrying out of unauthorized experiments, is forbidden.

2. Demonstrations with live material will not take place inside any building. Dummy material only will be used at lectures (*see* Vol. I, 1931, Sec. 6, 4).

3. No smoking will take place while live material is being handled.

4. Should a primed grenade not be expended, the *bursting set* or *detonator* will be at once removed and returned to its box. Particular care will be taken that no grenade is returned to store primed.

5. A book will be kept in which the numbers of grenades, *bursting sets* or *detonators* and gun-cotton *primers* drawn from store will be recorded in words and figures; numbers expended and returned will be similarly recorded and the totals balanced. Each person taking over the material will sign a receipt in a column or columns which will be provided for this purpose.

6. Steps will be taken to ensure that all concerned with the care, storage or handling of grenade stores are familiar with the distinctive markings of live and dummy material.

7. Operations with live material will only be carried out by a qualified person; in no case will this be done inside any building or in the presence of spectators.

8. Dummy grenades will not be filled for use as live ones.

9. Smoke grenades will be stored apart from all other material and will be frequently inspected for signs of leakage or corrosion, especially at the *detonator sleeve* and joints of the *body*. All grenades showing serious defects of this nature will be destroyed by blowing up.

32. *Ballistite grenade cartridge*

Cartridge, S.A., rifle grenade, .303-inch, ballistite, H, Mark IZ/L/.

This cartridge is for use with grenades fired from the *discharger*. It consists of a .303-inch *cartridge case* loaded with 30 grains of sporting ballistite. The space in the upper part of the case is packed with cotton wool and mouth closed by a paper or cardboard disc (or by a cardboard cup) secured by shellac varnish. For distinguishing purposes the case is blackened for *half its length* from the mouth and the mouth of the case is not crimped.

33. *Precautions against gas*

1. *Grenades*.—In the event of a hostile gas attack unboxed grenades should be kept covered. Those parts made of brass should be kept oiled to prevent their seizing from corrosion by the gas. The parts of the grenade requiring special attention are mentioned in the Appendices dealing with each particular type of grenade.

2. *Grenade dischargers*.—*Dischargers* will be cleaned and re-oiled, paying particular attention to the threads of the *locking base* and the *shutter*.

CHAPTER III

SMALL ARMS ANTI-AIRCRAFT TRAINING

GENERAL CONSIDERATIONS

34. *Responsibility of commanders*

It is the duty of every commander to make the necessary arrangements for the protection of his command from attack by aircraft with all the means at his disposal. (F.S.R., Vol. II, 1929, Sec. 58, 1.)

35. *Methods of air attack and value of small-arm fire*

1. Attacks may be made either by day-bomber aircraft from altitudes at which small-arm fire is ineffective, or by fast aircraft flying low.

In the former case there will usually be adequate warning owing to the height at which the aircraft fly, although in cloudy weather such warning will be reduced.

In the latter case, owing to the risk from small-arm fire, the aircraft will seek to effect surprise. They will, therefore, use clouds, low hills, woods, etc., for concealment, and by attacking out of the sun will endeavour to put the anti-aircraft defence on the ground at a disadvantage.

2. Low-flying attacks will be made at high speed and so will be quickly over. They may be repeated at short intervals. Usually a combination of bombs and machine-gun fire will be employed, machine guns being

used when diving to the attack; on occasions the attack may be purely by gas-spray, in which case the aircraft is more likely to fly straight over than to dive. In the case of two-seater aircraft, the rear machine guns may also be brought to bear as the aircraft is climbing and turning away.

Attacks may be made either individually by aircraft flying along a column and diving in succession, or by a simultaneous converging attack by several aircraft from different directions. With the first method little or no warning can be expected beyond, possibly, the noise of bombs exploding or of fire from other troops who are being attacked. With the second some warning should be forthcoming, as the aircraft must first get into a definite formation above their target.

Against undisciplined or demoralized troops such attacks may have a decisive effect, but against trained and disciplined troops their cost should be prohibitive.

3. Enemy reconnaissance aeroplanes searching for information are sometimes forced to fly low. Small-arm fire is of great value to prevent them achieving their object.

36. *General principles of small-arm defence*

1. Whenever the situation permits, every effort should be made to avoid all forms of air attack by concealment. When this is not possible, suitable formations will help to minimize casualties. Against low-flying attacks troops will defend themselves by small-arm fire (F.S.R., Vol. II, 1929, Sec. 58, 8, and Infantry Training, Vol. II, 1931, Sec. 34). To be effective such fire must be controlled.

Rifle fire may be taken as effective up to 2,000 feet. When suitably mounted, light automatics and machine guns may be used with effect up to 3,000 feet.

2. The efficiency of the defence will depend firstly on the speed at which warning of attack can be conveyed to subordinate commanders; secondly, upon the quickness with which the warning can be followed by executive orders for opening fire; and lastly, on the skill and fire discipline of the troops themselves. Since there will be no time to issue orders through the normal chain of command, responsibility must be delegated. It must be made clear to fire unit commanders whether they are to open fire on their own initiative or not.

3. It should be impressed on troops that, although small-arm fire may often appear to be ineffective, damage may be caused, which, although not obvious at the time, may subsequently put the aircraft out of action.

4. So far as existing equipment is concerned, the method of defence will depend upon whether troops attacked are in column or deployed, and whether in each case they are on the move, or halted either in reserve or resting. The principles which should govern the action of troops, and the anti-aircraft precautions to be taken, are laid down in Infantry Training, Vol. II, 1931, Sec. 34.

GENERAL INSTRUCTIONS FOR TRAINING

37. Personnel to be trained

1. *Rifle*.—The personnel of all arms equipped with the rifle.

2. *Light automatic*.—The personnel of all light-automatic sections in all arms.

3. In addition to the training of the above personnel in the use of their weapons, the following will be trained in *recognition* (Sec. 39) and *ranging* (Sec. 40):—

- i. All officers, warrant officers and N.C.Os. of and above the rank of serjeant in the cavalry and infantry.
- ii. One officer and one N.C.O. of each unit (other than cavalry and infantry) armed with the light automatic.
- iii. The personnel of H.Q. A.A. light automatic sections and of one light automatic section of each infantry company in possession of A.A.L.A. sights.

38. Primary considerations in training

1. Extreme accuracy of fire must give way to speed and volume. Estimation of range can be limited to a knowledge of when fire can usefully be opened.

2. Training, therefore, will primarily be concentrated on obtaining:—

- i. Speed in opening fire. The time available will depend upon early warning.
- ii. Strict fire discipline. Since the moral effect of air attacks will be considerable, fire must be carefully controlled.
- iii. Maximum volume of controlled fire, in view of the short duration of an attack.

3. Aircraft diving to attack, or climbing after attack, present the easier and more likely form of target. Crossing and overhead targets are more difficult. In training, therefore, attention will be concentrated firstly on the former and secondly on the latter.

39. Recognition

1. Those in constant practice can recognize aircraft by silhouette or, at closer ranges, by national markings. But, since in peace, practice in recognition of foreign aircraft is not possible, the most that can be aimed at, practically, is to train the necessary personnel (Sec. 37) to recognize our own aircraft. On the outbreak of war, silhouettes and markings of allied aircraft will be issued.

In training, emphasis should be laid on the necessity for trying to distinguish between a friendly aeroplane flying low in order to drop a message and a hostile one diving to attack.* But, at the beginning of a campaign, it must be realized that, in actual fact, any suspicious action by an aeroplane will render it liable to be fired on.

2. i. *Recognition by silhouette* demands a high standard of training, since hostile aircraft will usually present themselves head on, when identification is most difficult. Troops will, therefore, be trained in peace to recognize those types of our own aeroplanes which are most likely to be operating in their neighbourhood.

ii. Training will be carried out:—

(a) Out-of-doors by demonstration flights by the

* See also Infantry Training, Vol. II, 1931, Sec. 8, 25-27.

Royal Air Force and by observing aircraft which may fly over troops during training.

(b) Indoors, by diagrams.

Diagrams of selected aircraft as viewed at different angles are provided for display in barrack rooms, &c., and similar diagrams are also issued on small cards.

Instructors will point out the chief characteristics of the different types of British aircraft, and will give practice in recognition by silhouette by exposing a card showing an aeroplane and calling upon the personnel under instruction to identify the type illustrated. (See Sec. 55.)

3. i. *Recognition by national markings* offers the surest means of identification, but such markings are only visible at close range, when an aeroplane is crossing or overhead. (Sec. 40.) National markings consist of signs of different shapes and colours, standardized for each country. These are painted on the wings, body and tail.

ii. Training will be concentrated on teaching men to recognize British markings and will be carried out:—

(a) By observation of Royal Air Force aircraft.

(b) By means of diagrams of these markings, displayed on walls of barrack rooms, &c.

40. Ranging

1. Since the maximum effective range of small arms is 3,000 feet, and attacking aircraft will probably be

moving at a speed of nearly 100 yards a second, estimation of range, to be of any value, must be practically instinctive.

2. A knowledge of the appearance of aeroplanes at a range of 600 yards will be found useful, since the amount of detail visible is an aid to determining whether they are within or beyond this range. The following is a guide:—

- i. At 600 yards the aircraft is almost a silhouette. The national markings on the wings are visible, but the colours are not discernible; those on the tail and body are not visible.
- ii. At closer ranges such details as the pilot's head, struts and colours of national markings become better defined.
- iii. Beyond 600 yards the national markings quickly become indistinguishable; the aircraft will be a complete silhouette and the struts invisible; the speed appears greatly decreased.

3. For both rifle and light-automatic fire the range, in war, will normally have to be judged by eye.

4. Training will be carried out with the co-operation of aircraft when available, by demonstration flights arranged at 600 yards' distance and at distances over and within that range. Full use will be made of opportunities of ranging on aeroplanes during manoeuvres or at training.

41. *Warning and air sentries*

1. It must be realized that, in certain types of attack and under conditions favourable to, attacking aircraft, there will often be not more than a few seconds warning, even with quick well-trained air sentries. But, with well-trained and disciplined troops, even a few seconds will make all the difference. The number of air sentries to be detailed must depend on circumstances, but should not be less than two for each company or equivalent unit. The direction and area in which each sentry is to watch must be carefully regulated. They must be continually searching the sky, especially in the direction of the sun, towards low hills, woods, &c. They must also *listen* for the approach of aircraft. At the halt, if time allows, they should be posted as high as possible so as to get a clear view of a portion at least of the horizon. It is essential that an air sentry should not allow his attention to be distracted by anything happening elsewhere. Since their duties will be exhausting and will entail a great strain on the eyes, arrangements must be made for frequent reliefs.

2. In the case of an attack, two warning signals only will be used:—

- i. **Enemy aircraft in sight.**—A succession of long blasts on the whistle. Since this signal may often be inaudible, a visual signal will also be used to attract attention, viz., both arms held above the head and hands waved. On this signal troops will either get ready to fire, open out, or take cover, according to the orders in force (Sec. 36, 2).

ii. **Attack over.**—Two long blasts repeated at intervals of five seconds. On this, all troops resume previous formations. Troops who have been firing will recharge their magazines before moving off.

3. The personnel detailed in Sec. 37, 3, iii, will be trained in the duties of air sentries by observation of aircraft during manœuvres and at training.

METHODS OF TRAINING

The Rifle

42. *Subjects to be taught*

1. The rank and file will be trained in :—
 - i. Aiming and firing (Secs. 43 and 44).
 - ii. Strengthening exercise (Sec. 48).
 - iii. The standard test (Sec. 55).
 - iv. Fire discipline (Sec. 47).
2. The platoon (or equivalent unit) commander will be trained :—
 - i. As for rank and file (para. 1, above).
 - ii. In recognition and ranging (Secs. 39 and 40).
 - iii. In fire control (Sec. 46).

43. *Aiming instruction*

LESSON 1.—DIVING AND CLIMBING AEROPLANES

1. *Preliminaries.*
 - i. *Stores required.*—Model aeroplane with pole and stand (Appendix X), and aiming rests.
 - ii. Inspect arms, dummies, pouches. Loosen slings.

2. *Sequence of instruction.*

- i. State object of lesson—how to aim at enemy aeroplanes with speed and accuracy.
- ii. Using model, explain :—
 - (a) Diving—flying downwards towards the firer.
 - (b) Climbing—flying upwards away from the firer.
- iii. Teach parts of aeroplane :—

Nose (usual position of engine), wings, wheels.
Body (fuselage), pilot's position, tail.

Stage I. Diving aeroplanes

3. *Sequence of instruction.*

Model set up in diving position. Centre of aiming rest ten yards from the mounting.

- i. Teach two rules of aiming :—
 - (a) Sights at 600 yards.
 - (b) Take regulation aim at central portion of the body.
- ii. Demonstrate a correct aim, emphasizing position of the eye, *i.e.* over the heel of the butt.
- iii. Each man views correct aim.
- iv. Squad practises laying aims. Instructor checks.
- v. Give reasons for rules of aiming :—
 - (a) 600 yards found to be best average elevation for firing at aeroplanes up to 600 yards.

(b) The most vulnerable part of the aeroplane is the nose.

vi. Further practice if necessary.

Stage II. Climbing aeroplanes

4. Sequence of instruction.

Model set up in climbing position; distance as for diving.

i. Teach two rules of aiming:—

(a) Sights at 600 yards.

(b) Take regulation aim at centre of the lowest portion of the aeroplane.

ii. Demonstrate a correct aim.

iii. Each man views correct aim.

iv. Squad practises laying aims.

v. Further practice if necessary.

LESSON 2.—CROSSING AEROPLANES*

5. Preliminaries.

i. Stores required.—Model aeroplane with pole and stand, aiming rests, line of flight rod.

ii. Inspect arms, dummies, pouches. Loosen slings.

* If it is not possible to have the sky as a background to the model, the position of the mounting must be constantly changed laterally to prevent men selecting marks in the background which may give the *standard lead*.

Variation in the distance of the eye from the backsight protectors will cause a small difference in the *standard lead*. Instructors will make allowance, therefore, for slight personal variations.

6. Sequence of instruction.

i. Using model explain:—

(a) Direct crossing—flying horizontally across the firer's front.

(b) Crossing—flying in any other direction than as in (a).

ii. Refer to aiming off for movement against a target on the ground and bring out by question and answer:—

(a) Necessity for aiming in front of a moving target.

(b) That swing of the rifle must not be checked when firing at a moving target.

iii. Explain *standard lead*:—

(a) The required amount of lead can be found by measuring from the nose of the aeroplane along its line of flight the distance between the backsight protectors when the rifle is in the aiming position.

(b) That by practice, the *standard lead* should become instinctive so that it is not necessary to use the backsight protectors in order to estimate it.

iv. Teach two rules of aiming at all crossing aeroplanes:—

(a) Sights at 600 yards.

(b) Align the sights on the aeroplane and swing through it in the direction of flight.

Stage I. Direct crossing aeroplanes

7. Model aeroplane will be set up for direct crossing with rectangle in the *standard lead* position and raised to the correct line of flight. Distance from mounting to centre of aiming rests ten yards.

8. i. With rifle in the rest demonstrate correct *standard lead* as follows:—

Sights at 600 yards. Correct aim laid on centre of the rectangle.

ii. Order rectangle to be lowered.

iii. Each man views this *standard lead*.

iv. Squad, using rests, practises aiming off correct *standard lead*, using backsight protectors. Instructor checks by having rectangle raised to correct line of flight. Practise with aeroplane going from right to left and left to right.

v. Further practice.

Stage II. Crossing aeroplanes

9. Model aeroplane with a line of flight rod will be set up on the mounting at any angle to the direct crossing position and horizontal to the ground. The angle will not be too acute. A line of flight rod will also be used when checking aims to ensure that the rectangle is correctly aligned on the line of flight of the aeroplane.

10. i. With rifle in the rest demonstrate correct *standard lead*.

ii. Lower the rectangle.

iii. Each man views this *standard lead*.

iv. Squad using rests practises aiming off. Instructor checks as in Stage I.

v. Further practice at direct and other crossing planes without using backsight protectors or the rod.

vi. Instructor will set the model at a very acute angle and explain that in such a case the firer must use his own judgment in the amount of lead which he takes.

44. Firing instruction

LESSON 3.—FIRING INSTRUCTION (RIFLE)

1. Preliminaries.

i. *Stores required*.—Model aeroplane with pole and stand, aiming rest, aim corrector. Model in diving position not more than six yards from squad.

ii. Inspect arms, dummies, pouches. Loosen slings. Squad extended in single rank. Charge magazines. Sights set at 600 yards. Squad rests.

2. Sequence of instruction.

i. State object of lesson is how to engage enemy aeroplanes with fire.

ii. Explain that fire will be in single shots. For each shot the command "Fire" will be given by the fire unit commander, usually the platoon commander.

- iii. Give complete demonstration, naming phases :—
Loading position.
Loading.
Aiming and firing.
Stop.
Charging magazines.
- iv. State that this position will be used when engaging enemy aircraft.

Stage I. Loading position—Loading— Charging magazines

3. Sequence of instruction.

i. Squad imitates instructor :—

(a) Adopt the normal loading position (standing), except that the butt will rest on the belt, barrel as vertical as possible, and load.

(b) Open the breech and charge the magazine.

ii. Squad returns to the order.

iii. Men practise individually. Instructor checks.

iv. While squad rests, instructor states that rifles will be kept vertical as a safety precaution.

v. Further practice by word of command.

Stage II. Safety angle

4. Sequence of instruction.

i. Assisted by one of the squad demonstrate with detail the safety angle of 25 degrees. When the upper part of the left arm is parallel to the ground, the rifle in the aiming position is

approximately at an angle of 25 degrees from the horizontal.

ii. Men practise in pairs—"Master and Pupil"—until they can judge when the safety angle is reached without looking at the arm. Instructor checks.

Stage III. Aiming and firing

5. Sequence of instruction.

i. Squad practises by word of command. Instructor checks.

ii. Model changed to climbing position.

iii. Practice continued as in sub-para. i, above.

Stage IV. Crossing aeroplanes

6. The model will be carried at a slow walk directly across the front of the squad at not more than six yards' distance.

7. i. Refer to the two rules of aiming at crossing aeroplanes, by "question and answer."

i. Demonstrate firing. Squad will stand directly behind the instructor and be told to watch the swing of his rifle.

iii. Squad in line not more than six yards from model, ordered to load. Men practise firing at the model by word of command.

iv. Practice by word of command at the model carried diagonally across the front at slow walk.

- v. Further practice by word of command at direct and other crossing aeroplanes, increasing the speed at which the model is carried up to a fast walk.

45. Firing with .22-inch ammunition

1. Where requirements of safety permit, firing instruction can be given by carrying out practices with .22-inch ammunition on a classification range.

2. The "A.A." moving target (Vol. V, 1931, Plate 65) should be set up at the butts at a range of ten yards from target to firer's eye. In order to arrange realistic elevation an angle of sight of 25 degrees may be obtained by raising the target or by allowing the man to fire from a trench, or by a combination of these methods.

3. The minimum size of range required is an eight-target range with the run of the "A.A." target not more than twelve feet. This allows for an arc of fire of 22 degrees, the centre line of which must be directly up the range.

4. When it is not practicable to obtain the necessary elevation, useful instruction can be given with the firer and target on the same level. This instruction may be given on a 30-yards' range, at a range of ten yards from target to firer's eye.

5. For firing with the rifle the position of the scoring card carrier must be altered in order to correct the position of the M.P.I. for the "standard lead" and for elevation.

The measurement from the nose of the aeroplane to

the M.P.I. must be increased from 28½ inches (*see* Vol. V, 1931, Plate 65, Fig. 3) to 35½ inches, and fresh notches cut to carry the legs in this new position.

The legs themselves must be 6½ inches shorter, in order to move the M.P.I. vertically from 5½ inches below the line of flight to 1 inch above the line of flight. The sights of the rifle will be set at 600 yards, as is normal for "A.A." rifle fire.

46. Fire control

I. The platoon, or corresponding sub-unit, will be the fire unit. On receiving warning of an impending attack (*see* Sec. 41) the company commander will give the cautionary word of command, "Aircraft Action." On this the platoons, &c., will act as follows:—

I. Platoon commanders will give the command, "No. . . . platoon, &c., Aircraft Action." On this the platoon, &c., will halt and act as in *Lesson 4, Stages I, 3, i or II, 4, ii.*

II. To open fire the fire unit commander will give the command "Aircraft—front (right, &c.)" according to position of aircraft to be engaged. On this order each man will act as in *Lesson 4, Stage III, 5, ii*; after sufficient pause the command "Fire" will be given, when each man will fire one round, maintaining the correct lead and swing. (*See Lesson 4, Stage III, 5, iii.*) The command "Fire" produces a burst of fire from the platoon to which each rifleman contributes one round. If, therefore, more than one burst of fire is possible at the same aeroplane,

the platoon commander will repeat the order "Fire" for each additional burst. By this means fire control is maintained.

2. i. The command "Stop" will *not* be given when switching fire on to another aeroplane. The only order necessary in such a case will be, "Aircraft About (Left, &c.)," followed by the command or commands "Fire" as above.
 - ii. If, however, the fire unit commander wishes to stop firing momentarily for some special reason, such as no aeroplane within range, he will give the command "Stop." On this the men will return to the loading position and refill magazines.
3. When the attack has definitely ceased and the "Attack Over" signal has been given, the fire unit commander will give the command "Stop," followed by "Charge Magazines" and "Close" (*see Lesson 4, Stage III, 5, v*).
4. Platoon sergeants and section commanders will *not* fire. They will repeat all commands of the fire unit commander when necessary, assist in the control of fire, and ensure that men do not fire when their rifles are below the safety angle, *i.e.* 25 degrees.
5. Fire orders will be by word of command. The whistle will only be used to attract attention.

47. Fire discipline training

LESSON 4.—FIRE DISCIPLINE TRAINING

1. *Preliminaries.*
 - i. *Stores required.*—A model on a pole or running on a wire.
 - ii. Inspect arms, dummies and pouches. Loosen slings. Place one filled charger in a convenient pocket.
 - iii. Form squad in fours as on left of a road.
 - iv. "Standing position—Charge magazines—600—Sling arms."
2. *Sequence of instruction.*
 - i. State lesson is to teach men how to engage enemy aircraft when suddenly attacked on the line of march.
 - ii. Emphasize:—
 - (a) Speed at which the attack develops.
 - (b) Short time aircraft is within range.
 - (c) Safety and morale.

Stage I. Fours on one side of the road
3. *Sequence of instruction.*
 - i. Explain what to do on the command, "No. . . . Platoon, Aircraft Action": Open out to one pace interval, bring the rifle to the loading position and load.
 - ii. Give command, "No. . . . Platoon, Aircraft Action." Squad acts as in sub-para. i, above.

- iii. Give command, "Charge magazines."
- iv. Explain what to do on the command, "Close":—
 - (a) Face original front (if not already doing so).
 - (b) Re-form sections of fours.
 - (c) Sling arms.
- v. Give command, "Close."
- vi. Squad practises on the commands, "No. . . . Platoon, Aircraft Action"—"Charge Magazines"—"Close."

Stage II. Files on each side of the road

4. Sequence of instruction.

- i. Form squad up with files on each side of the road.
- ii. Explain that on the command "No. . . . Platoon, Aircraft Action," the files on the left will extend, and that those on the right will close in towards the left until each section of fours is complete at one pace interval. This will be reversed where troops normally march on the right of the road. All other actions are the same as in the previous stage. On the command "Close," the original march formation will be resumed.
- iii. Squad practises on the commands "No. . . . Platoon, Aircraft Action";—"Charge Magazines";—"Close."

Stage III. "Aircraft Front"—"About"—"Right"—"Left"

5. Sequence of instruction.

- i. Give command, "No. . . Platoon, Aircraft Action—Rest."
- ii. Explain what to do on the command, "Aircraft Front," "About," "Right" or "Left." Each man will turn in the required direction, come into the aiming position, commence swinging to get the correct lead in the case of all crossing aeroplanes.
- iii. Explain what to do on the command, "Fire." Each man will fire one round on each order "Fire" until the order "Stop" is given or until he has reached the safety angle, when he will return to the loading position and recharge his magazine.

iv. Squad practises.

Examples of words of command are:—

"Position"—"Aircraft Front—Fire"
 —"Aircraft Right—Fire"—"Fire"
 —"Aircraft About—Fire."

These will be repeated as required. In this stage the command "Stop" will be used to finish practice.

- v. After sufficient practice the order "Charge Magazines" will be given, followed by the order "Close." On this order men will pick

up any live ammunition lying in the road near them and will close as already taught.

- vi. Further practice combining Stages I and III, and Stages II and III.

Stage IV. Platoon on the line of march

6. Sequence of instruction.

- i. Platoon resting on one side of the road with equipment off.
- ii. Mention that at halts each man will have one charger in a pocket ready for immediate use.
- iii. Give command, "No. . . . Platoon—Aircraft Action." On this command Nos. 1 and 2 of light automatic sections, if with the platoon, will move clear to the inner flank.
- iv. When the platoon has opened out it will be practised by words of command dealing with the situations referred to in Sec. 46. 1, ii and 2.
- v. Platoon practises.
- vi. Further practice with platoon fallen out on both sides of the road.
- vii. Repetition. Further practice on the march using both formations. Dummies will not be used.

48. Strengthening exercise

LESSON 5.—STRENGTHENING EXERCISE

1. Preliminaries.

- i. Inspect arms, dummies and pouches. Loosen slings.

- ii. Squad in line and extended.

iii. Point out target. The object chosen as a target for this exercise will be some well-defined edge or line, such as a roof-line, skyline, or telegraph wires. It should be at the highest possible angle and must not in any case be at a line of sight less than 25 degrees. Suitable diagonal lines, if available, should also be made use of.

- iv. Dummies will not be used and bayonets will not be fixed.

2. Sequence of instruction.

- i. State object is to practise swinging correctly and evenly, and to strengthen the muscles employed.
- ii. Give complete demonstration and then explain how to carry it out:—

"Without Dummies—Standing—Load—Commence." On the word "Commence," bring the rifle to the aiming position and take the first pressure, roughly align the sights on the object chosen and swing along its length in one direction, return to the loading position, repeat in the reverse direction, and continue this until the command "Loading Position" is given.

- iii. "Unload."

- iv. Squad practises.

The Anti-Aircraft Light Automatic

49. Subjects to be taught

1. Personnel of light automatic sections (other than H.Q.A.A. personnel and one specially trained light automatic section of each company) will be trained:—

- i. In A.A. aiming (Sec. 50).
- ii. In elementary handling (Sec. 52).
- iii. To pass standard tests (Sec. 55).

2. H.Q.A.A. personnel and one specially trained light automatic section of each company will be trained:—

- i. As in para. 1, above.
- ii. In recognition and ranging (Secs. 39, 40, and Appendix X).
- iii. As air sentries (Sec. 41).

In the case of H.Q.A.A. teams, the No. 3 will act as the fire unit commander. Each man will be trained to control the movement and fire of the gun.

50. Aiming instruction

LESSON 6.—AIMING INSTRUCTION

1. Preliminaries.

- i. *Stores required.*—Gun, magazine, spare parts, A.A. sights, A.A. mounting, mounting holder, rifle sling, A.A. aim corrector, model aeroplane with pole and stand, line of flight rod.
- ii. Model to be ten yards from the gun.

2. *Sequence of instruction.*—State object of lesson is how to engage enemy aircraft, using anti-aircraft sights.

Stage I. A.A. mounting—Mounting holder—Foresight—Backsight

3. Sequence of instruction.

- i. Show and describe A.A. mounting (*see* Appendix IX).
- ii. Attach the *sling*.
- iii. Describe the following (*see* Appendix IX) and explain the method of fixing them. Interrogate after each part and practise one of the squad in fixing the part.

(a) *Mounting holder.*—Place the *gun band* of the *holder* over the junctions between the *body* and the *rear radiator casing*. Slide it forward until it is seated between the two *mounting rings* on the *rear radiator casing*. Turn it until the *clamping screw* is on the right. Before tightening the *wing nut* see that the *leg* of the *holder* is in line with the *pinion casing*. This ensures that the *sights* are upright when mounted.

(b) *A.A. foresight.*—Slide the *foresight* over the *front radiator casing*, the *rings* towards the ground and the *vice-pin screw* to the left of the gun. Slide the *sight* along the *casing* until it is behind the *clamp ring*. Then twist it round until the *rings* are uppermost. Press it up tight to the *clamp ring* and screw until there is no chance of slipping.

When screwed up, the *pointer* on the *foresight* should be in exact alignment with the *foresight* on the gun. Great care must be taken that the *spring steel ring* is not strained in any way. When the *foresight* is not in use it will be folded flat on the *radiator casing*.

- (c) The aperture portion is placed on the graduated side of the *tangent sight leaf*, with the block fitting into the *recess* at the top of the *leaf*. The smaller portion, together with the *spring washer*, is placed on the other side of the *leaf*, and the whole is then screwed together.

iv. Interrogate squad as to positions and parts of an aeroplane.

Stage II. Diving and climbing aeroplanes

4. Sequence of instruction.

i. Model set up in diving position. Put aim corrector on the gun and mount it. Put on a magazine.

ii. Teach three rules of aiming :—

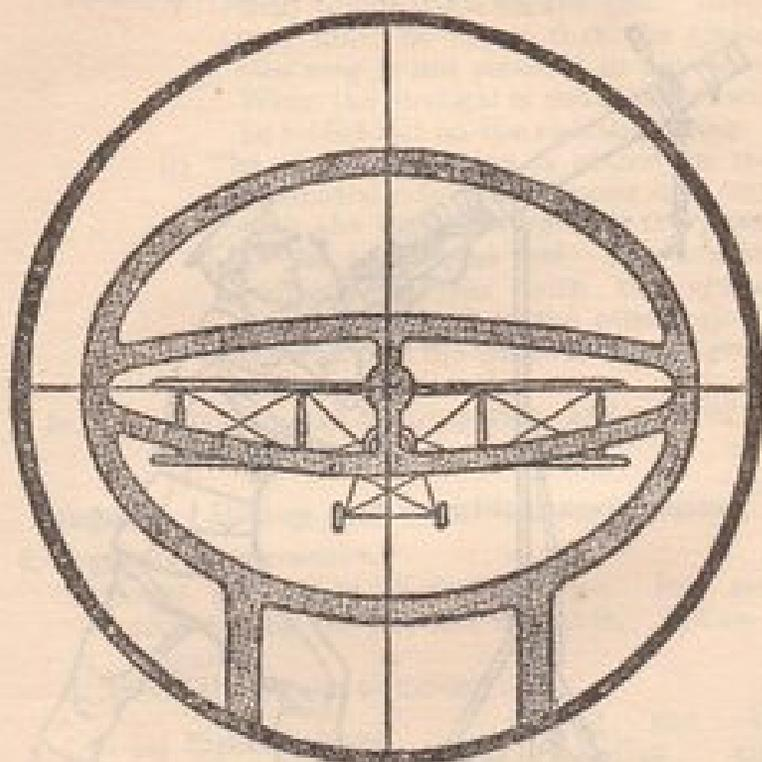
- | | |
|--|-------------------------------------|
| (a) Sights upright. | } Bring out by question and answer. |
| (b) Close disengaged eye. | |
| (c) Aim will be taken by aligning the centre bead of the A.A. foresight on to the centre of the upper wing of the aeroplane; the bead to be in the centre of | |

PLATE 14

AIMING AT AIRCRAFT (GUN AT 25 DEGREES)



PLATE 15
CENTRE BEAD IN USE



Correct.—The aeroplane is diving at the position of the gun. Aim has been taken by aligning the bead with the centre of the backsight aperture upon the middle of the upper plane. The bullets will hit the vital parts of the aeroplane.

the aperture of the A.A. backsight. Refer to the 3rd rule with the ground sights (*see* Plate 15).

- iii. Demonstrate a correct aim. Instructor emphasizes correct position of the firer's body (*see* Plate 14).
- iv. Each man views correct aim.
- v. Each man lays correct aim. Instructor checks.
- vi. Set up model in climbing position.
- vii. Bring out by question and answer that three rules of aiming are as for diving aeroplane.
- viii. Demonstrate a correct aim.
- ix. Each man views correct aim.
- x. Each man lays correct aim. Instructor checks.

Stage III. Crossing aeroplane

5. Sequence of instruction.

- i. Model set up in direct crossing position.
- ii. In the case of any crossing aeroplane explain the conditions which govern the use of the two rings on the foresight:—
 - (a) The inner ring will be used when the angle of the gun is 25 degrees or under.
 - (b) The outer ring will be used when the angle of the gun is over 25 degrees.

The angle of the gun is approximately 25 degrees from the horizontal when the bipod leg clamping screw is in line with the top of the pillar of the mounting (*see* Plate 14).

iii. Teach three rules of aiming :—

1st and 2nd rules as for diving and climbing by question and answer.

3rd rule (see Plates 16 and 17) :—

- (a) The line of flight of the aeroplane if prolonged, must pass through the centre bead of the foresight.
- (b) The top half of the foresight will be used in the case of aeroplanes which, while maintaining the same altitude are going away, and the bottom half for those coming towards the firer.
- (c) The nose of the aeroplane must appear to touch the outer edge of whichever ring is being used. This junction is known as the *point of contact*.
- (d) The *point of contact* must be in the centre of the A.A. aperture backsight.

The 3rd rule will be taught by diagram.

iv. Demonstrate a correct aim at direct crossing model. Instructor emphasizes the "foot work" necessary to keep the body in the correct position.

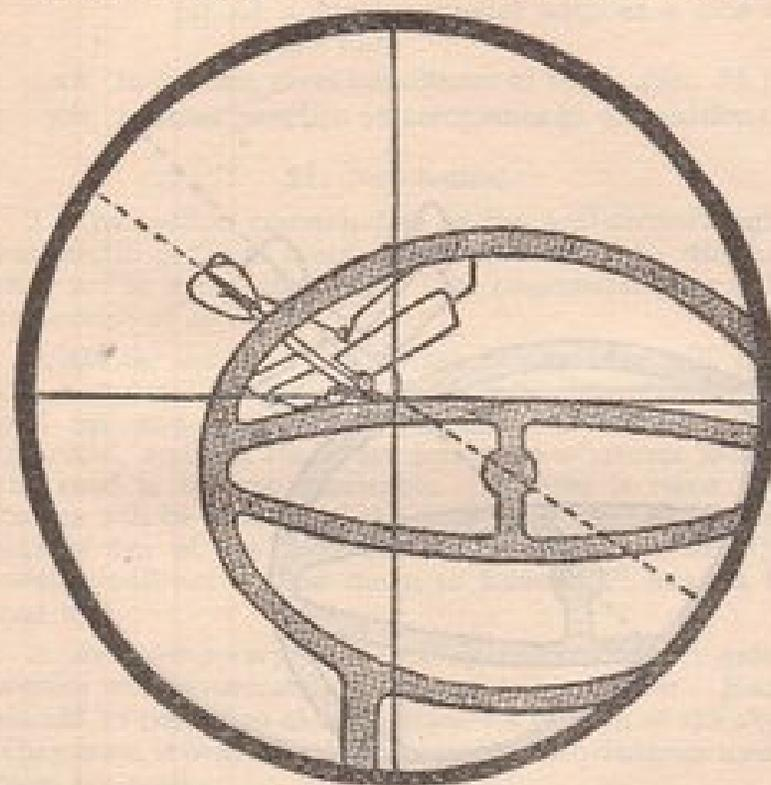
v. Each man views correct aim through the aim corrector.

vi. Squad practises aiming at all crossing planes as follows :—

- (a) At a stationary model with a line of flight rod.
- (b) At a moving model with a line of flight rod.

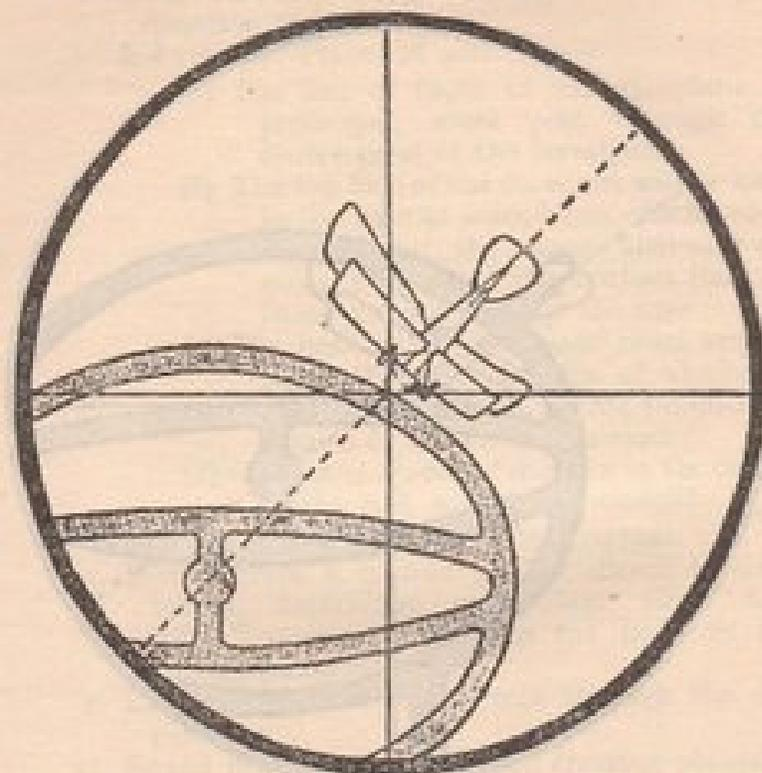
PLATE 16

INNER RING IN USE (25 DEGREES AND UNDER)



Correct.—The aeroplane is flying towards the centre bead, the nose of the aeroplane is touching the outer edge of the ring being used, and the point of contact between the nose of the aeroplane and the outer edge of the ring is in the centre of the backsight aperture.

PLATE 17
OUTER RING IN USE (OVER 25 DEGREES)



Correct.—The aeroplane is flying towards the centre bead, the nose of the aeroplane is touching the outer edge of the ring being used, and the point of contact between the nose of the aeroplane and the outer edge of the ring is in the centre of the backsight aperture.

(c) At a stationary model without a line of flight rod.

(d) At a moving model without a line of flight rod.

vii. Instructor gives conditions of test. (Sec. 55.)

viii. Further practice at aeroplanes in all positions.

51. Fire control

1. The section commanders of the anti-aircraft light automatic sections must receive orders as to whether they are to open fire on their own responsibility or only on receipt of an order.

2. *On the march.*—The section commander will give the command "Aircraft Action." The driver will pull up, and the light automatic will be taken off, mounted, and got ready for action on whatever side of the road is the more suitable. If there is room, the limber will be moved off the road clear of the probable line of fire of the light automatic. To open fire the section will act as laid down in Lesson 7, Stages II and V.

3. *At a temporary halt.*—All anti-aircraft light automatics will immediately be brought into action. Each should be posted so as to command a portion of the sky. They may, if convenient, be moved a little distance away from the road.

4. *During long halts.*—When at rest or when halted for periods of one hour and upwards, the available anti-aircraft light automatics will be disposed so that fire may be concentrated by not less than two guns in any

direction. Guns should be sited at the angles of an equilateral triangle, the sides of which are not less than 500 yards or more than 800 yards. All anti-aircraft light-automatic sections must know where their air sentries are posted, and be able to see at least one.

5. *Magazines* for anti-aircraft use should be loaded as follows :—

In every five rounds there should be one round of tracer and four of Mark VII ammunition. If armour piercing ammunition is being used, in every five rounds there should be two rounds armour piercing, one tracer, and two of Mark VII.

52. Elementary handling

LESSON 7.—ELEMENTARY HANDLING *

1. Preliminaries.

i. *Stores required.*—Gun, magazines, spare parts, ground sheets, A.A. sights, A.A. mounting, sling, mounting holder, A.A. aim corrector, model aeroplane with pole and stand.

ii. Three ground sheets to be laid out, two yards apart, five yards in rear of the action position.

iii. Gun, with A.A. sights and mounting holder attached, on the right sheet. Magazines and spare parts on the centre sheet. A.A. mounting with sling attached on the left sheet.

* In this lesson wherever the actions of gun numbers are similar to those in ground Elementary Handling, the actions and the reasons for them will be brought out by question and answer.

iv. Model set up in any position ten yards from the action position.

v. Squad will fall in on right of action position and number off.

2. *Sequence of instruction.*—The instructor states object of lesson :—

To teach the duties of Nos. 1, 2 and 3 in handling the gun against aircraft.

Stage I. "Take Post" and "Clear Gun"

3. *Sequence of instruction.*

i. *Take Post.*—Action of No. 3.

Instructor demonstrates action of No. 3 on command "Take Post," giving detail as follows :—

(a) Assume the kneeling position and examine the mounting.

(b) Sling the mounting over either shoulder.

(c) Report to No. 2, "Mounting correct."

ii. Instructor questions squad, giving reasons for :—

(a) Mounting examined to see that it is not damaged and works freely.

(b) For convenience in carrying.

(c) To let No. 2 know that No. 3 has carried out his duties.

iii. *Take Post.*—Action of No. 2 (question and answer).

(a) Position, kneeling.

- (b) Examination of magazines and passing one magazine to No. 1 (imaginary); placing remainder in carrier.
- (c) Examination of spare parts holdall.
- (d) Explain that the holdall will be slung on either shoulder.
- (e) Reporting to No. 1: "Magazines, spare parts and mounting correct."

iv. *Take Post*.—Action of No. 1 (question and answer).

- (a) Position, kneeling.
- (b) Examination of gun, including A.A. sights and holder.
- (c) Explain that the A.A. foresight will be raised.
- (d) Placing of magazine on gun.
- (e) Reporting to section commander: "No. . . . gun ready."

Order three of the squad to "Take Post."

v. *Clear Gun*.—Action of No. 1 (question and answer).

- (a) Position, lying.
- (b) Removal of magazine.
- (c) Clearing gun.
- (d) Lowering of A.A. foresight.
- (e) Come to attention.

No. 1 will not report "Gun clear" until all three numbers are at attention.

vi. *Clear Gun*.—Action of No. 2 (question and answer).

- (a) Replacing of magazine in the carrier.
- (b) Placing holdall on the ground.
- (c) Returning to attention.

vii. Explain that No. 3 will place the mounting on the ground and return to attention.

viii. Give order: "Clear gun."

ix. Squad practises "Take Post and "Clear Gun," each man in turn performing the duties of Nos. 1, 2 and 3.

Stage II. "Aircraft Action" and "Cease Firing"

4. *Sequence of instruction.*

- i. Instructor orders three of the squad to "Take Post." When gun is reported ready tells them to join the squad. Instructor puts on the aim corrector.
- ii. Action of No. 3.—Instructor demonstrates action of No. 3 on command: "Aircraft Action," giving detail as follows:—

(a) Double to action position and put up the mounting as quickly as possible. See that the height is suitable to the firer.

(b) Take up position on the right of the mounting and assist No. 1 to mount the gun. Then, if acting as fire unit commander, move to a position in the

vicinity of the gun from which he can observe fire.

iii. Action of No. 1.—Instructor demonstrates action of No. 1, one of squad in position as No. 3:—

- (a) Pick up the gun as in ground elementary handling, and double to the action position.
- (b) With the assistance of No. 3 mount the gun.
- (c) Load and raise the backsight.
- (d) Aim and fire—continuous fire.

iv. Instructor questions squad, giving reasons for:—

- (a) As in ground elementary handling.
- (c) As in ground elementary handling.
- (d) To produce greatest volume in the shortest time.

v. Action of No. 2.—Instructor demonstrates action of No. 2. One of squad in position as No. 1 will load, aim and fire when the instructor arrives in position as No. 2.

- (a) Pick up magazine carrier; double to the action position on the left of No. 1.
- (b) Call out to No. 1 "Outer" or "Inner" according to angle of gun.
- (c) Take one magazine from the carrier, holding it as in ground elementary handling.
- (d) Place magazine carrier on the ground near the mounting.

vi. Instructor questions squad, giving reasons for:—

- (b) Because No. 1 cannot aim, and note the angle of the gun at the same time.
- (c) As in ground elementary handling.
- (d) For quickness and convenience.

vii. Put one of squad in position as No. 2. Instructor explains that on the command "Cease Firing" Nos. 1 and 2 will act as in ground elementary handling except that they will kneel down when at the cease firing position. Instructor explains that No. 3 will:—

- (a) Assist No. 1 to dismount the gun.
- (b) Take the mounting to the cease firing position and kneel down.
- (c) Fold up the mounting and sling it on either shoulder.

viii. Instructor gives command "Cease Firing."

ix. Squad practises "Aircraft Action" and "Cease Firing," each man acting as Nos. 1, 2 and 3. Instructor checks aim by means of aim corrector.

Stage III. Changing magazines—Stop—Go on

5. Sequence of instruction.

- i. Gun to be in the *action* position. When this stage starts a fresh period the instructor will order three of the squad to "Take Post" and, when the gun is reported ready, will order "Aircraft Action—Rest."

- ii. Instructor explains that the actions when changing magazines or on the orders "Stop" and "Go on" are the same as in ground elementary handling except that, when the magazine has been changed or the order "Go on" is given, No. 2 will call out "Outer" or "Inner" according to angle of gun.
- iii. Squad practises "Changing Magazines," "Stop" and "Go on," each man acting as Nos. 1, 2 and 3.
Instructor checks aim by means of aim corrector.

Stage IV. Changing from air to ground target

6. Sequence of instruction.

- i. Instructor gives the command "Aircraft Action" and "Stop." Then removes the aim corrector.
- ii. Instructor explains that on the command "Action" No. 1 will:—
 - (a) Assisted by No. 3, dismount the gun.
 - (b) Mount the gun in a suitable position on the ground.
 - (c) Fire as ordered.
 No. 2 will take up position on the ground as taught in "Ground Elementary Handling."
 No. 3 will:—
 - (a) Assist No. 1 to dismount the gun.
 - (b) Occupy a position from which he can control the fire of the gun, taking the mounting with him and laying it on the ground.

- (c) Give a suitable type of fire control order.
- iii. Instructor gives the command "Action" and a brief fire control order. Having checked faults, give the command "Aircraft Action."
- iv. Squad practises, each man acting in turn as Nos. 1, 2 and 3. Instructor gives commands as in iii, above.
If the ground target is to a flank, the direction of it will be given before the command "Action," e.g. "Half Right—Action."
Instructor will occasionally introduce "Cease Firing" before "Aircraft Action."
- v. Further practice. Squad practised in all stages of this Lesson, No. 3 taking command and giving orders.

Stage V. Limber drill

7. Preliminaries.

- i. *Stores required.*—Limber (or table); gun with A.A. sights, mounting holder and aim corrector; spare parts holdall; 4 magazines in a carrier; A.A. mounting with sling.
- ii. Model set up in any position ten yards from the action position. The action position will be five yards from the limber. Squad fall in behind the limber and are numbered off.

8. Sequence of instruction.

- i. State lesson is to teach the duties of Nos. 1, 2 and 3 in aircraft action from the limber.

- ii. Teach the action of No. 3 by question and answer.
 - (a) Takes the mounting and mounts it as already taught.
 - (b) Assist No. 1 to mount the gun.
 - (c) Raise the A.A. foresight.
 - (d) Move to position from which he can observe fire.
- iii. Teach the action of No. 1 by question and answer.
 - (a) Doubles with the gun to the action position and mounts it, assisted by No. 3.
 - (b) Raise the backsight. As soon as No. 2 has placed a magazine on the gun, load.
 - (c) Aim and fire.
- iv. Teach the action of No. 2 by question and answer.
 - (a) Slings spare parts holdall on either shoulder.
 - (b) Takes the magazine carrier and doubles into position on the left of No. 1.
 - (c) Takes out a magazine and places it on the gun.
 - (d) Calls out to No. 1 "Outer" or "Inner."
 - (e) Takes another magazine from the carrier and places the carrier on the ground.
- v. Tell off three of the squad to carry out the duties taught in ii, iii and iv, on the command "Aircraft Action."

- vi. Give command "Aircraft Action" and check the aim with the aim corrector.
- vii. Bring out by question and answer the duties of Nos. 1, 2 and 3 on the command "Cease Firing." These are as already taught, with the following exceptions:—
 - (a) No. 3 will lower the A.A. foresight.
 - (b) No. 2 will replace all magazines.
 - (c) Stores will be replaced on the limber.
- viii. Give the command "Cease Firing." Instructor checks.
- ix. Squad practises "Aircraft Action" and "Cease Firing."
- x. Instructor gives conditions of test (Sec. 55).

53. Criticism of groups

LESSON 8.—CRITICISM OF GROUPS (FOR INSTRUCTORS ONLY)

1. Preliminaries.
 - i. Stores required.—Any flat surface to which aeroplane silhouettes can be fastened, aeroplane silhouettes, A.A. mounting, gun with A.A. sights and mounting holder, aim corrector, prepared groups.
 - ii. Gun set up ten yards from silhouette.
2. Sequence of instruction.
 - i. State object is to teach instructors the correct method of criticising groups fired in A.A. practices.

ii. Crossing aeroplanes:—

- (a) Explain that holding must be considered first.
- (b) Point out that, providing the mounting holder has been correctly put on, there will be no errors due to inclined sights.
- (c) Interrogate the squad on the 3rd rule of aiming, pointing out that an error may be made in each part.
- (d) Explain that the system of criticism will be to discuss with the firer in the following order:—

Holding,

Line of flight,

Point of contact,

Centring of contact in the aperture.

(Causes only very small error of about 2 inches at 10 yards.)

Error in position of a group may be caused by any one of the above, or a combination of them. This being so, the fault, or faults, can only be arrived at by a process of deduction.

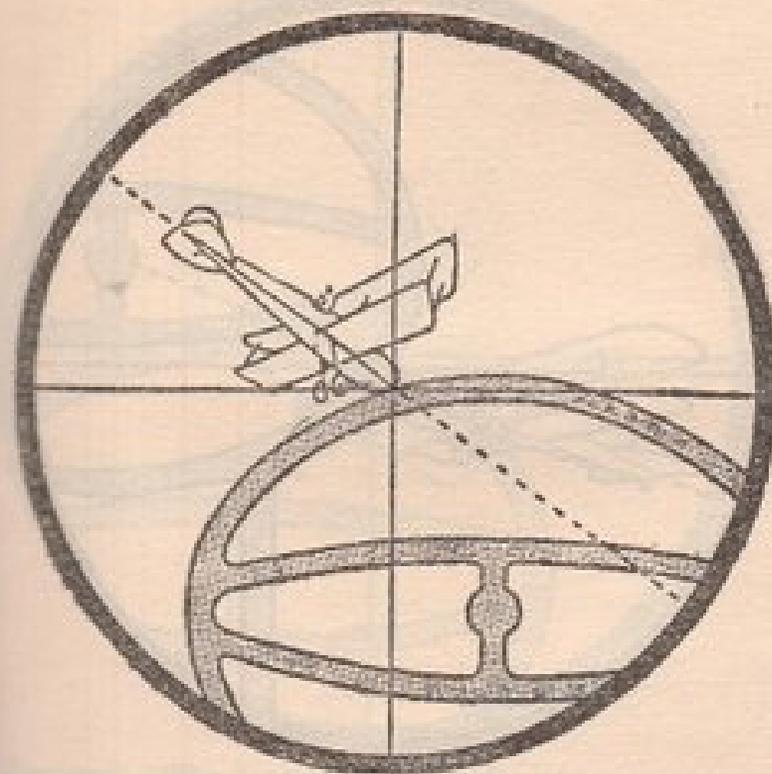
When criticising groups fired at moving targets, the swing must be considered in conjunction with the four headings above.

iii. Teach where the group will be if (Plates 18, 19, 20 and 21):—

- (a) *Line of flight* is incorrect if the aeroplane is passing above the bead, *i.e.* high

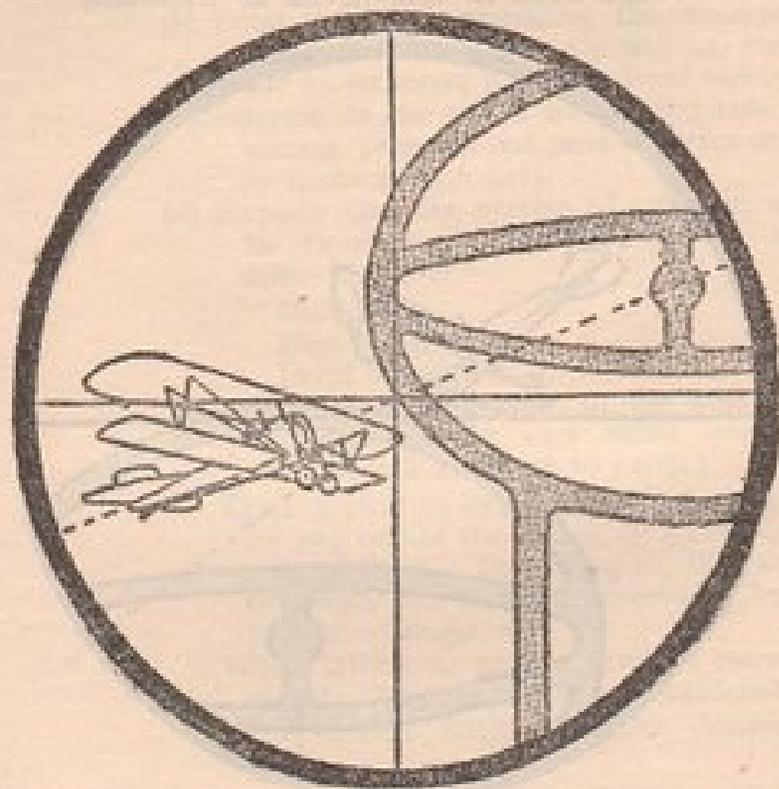
PLATE 18

OUTER RING IN USE (OVER 25 DEGREES)



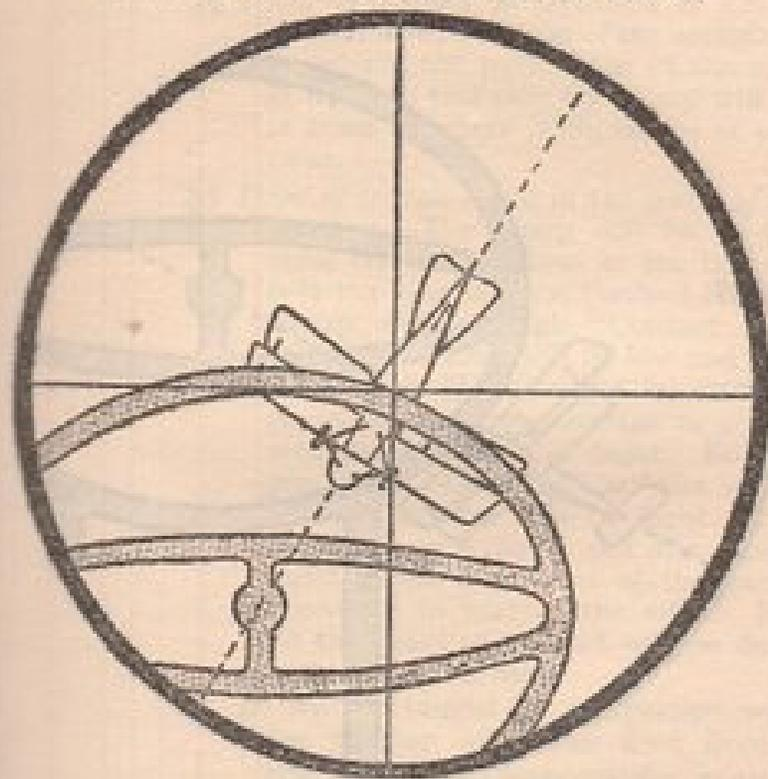
Incorrect.—The aeroplane is *not* flying towards the centre bead. The bullets will pass below the target.

PLATE 19
OUTER RING IN USE (OVER 25 DEGREES)



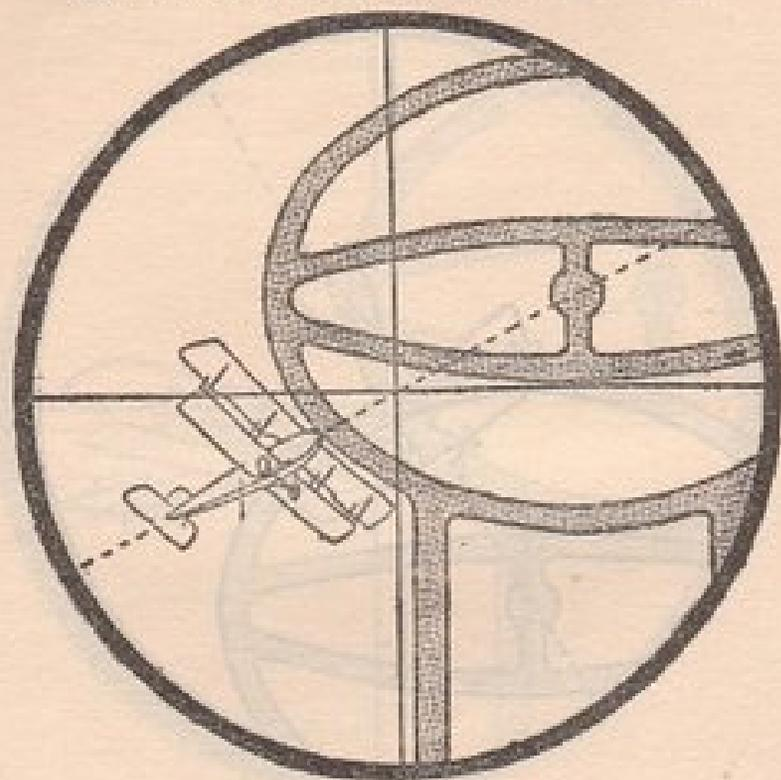
Incorrect.—The nose of the aeroplane is not touching the outer edge of the ring. Fire has been opened too soon and the bullets will pass in front of the target.

PLATE 20
OUTER RING IN USE (OVER 25 DEGREES)



Incorrect.—The nose of the aeroplane is not touching the outer edge of the ring. Fire has been opened too late and the bullets will pass behind any vital portion of the aeroplane.

PLATE 21
OUTER RING IN USE (OVER 25 DEGREES)



Incorrect.—The point of contact between the nose of the aeroplane and the outer edge of the ring being used is *not* in the centre of the back sight aperture. The bullets will pass in rear of the aeroplane.

line of flight, the group will be low, and *vice versa*.

(b) *Point of contact* is incorrect if fire is opened when the nose of the aeroplane is outside the outer edge of the ring in use; in this case the group will be in front of where it should be or *vice versa*.

(c) *Point of contact* is not in the *centre of the aperture*.—The group will be in the same relative position as the contact is in the aperture, *i.e.* Contact High—Group will be high. Contact Low and Left—Group will be low and left.

(a) and (b) will be taught by using a pencil or dummy cartridge to represent the aeroplane in flight. For (a) pencil will be held so that aim would be incorrect for line of flight. The instructor will point out the movement in the alignment of the barrel necessary to correct the error. For (b) the point of contact will be dealt with on similar lines.

(c) will be taught by comparison with the position of a shot fired from a rifle with an inaccurately centred foresight.

iv. Teach by question and answer where the group will be if the firer has a combination of the above faults, *e.g.* fire is opened when the

"line of flight" is passing under the bead, and the nose of the aeroplane is outside the outer edge of the ring. The group would be high and too far in front. For instance of effect of incorrect aiming, see Plate 22.

- v. Instructor will demonstrate the method of criticising a group. (Inaccurate centring of "Point of Contact.")
- vi. Squad practises criticising groups placed on the target by the instructor.

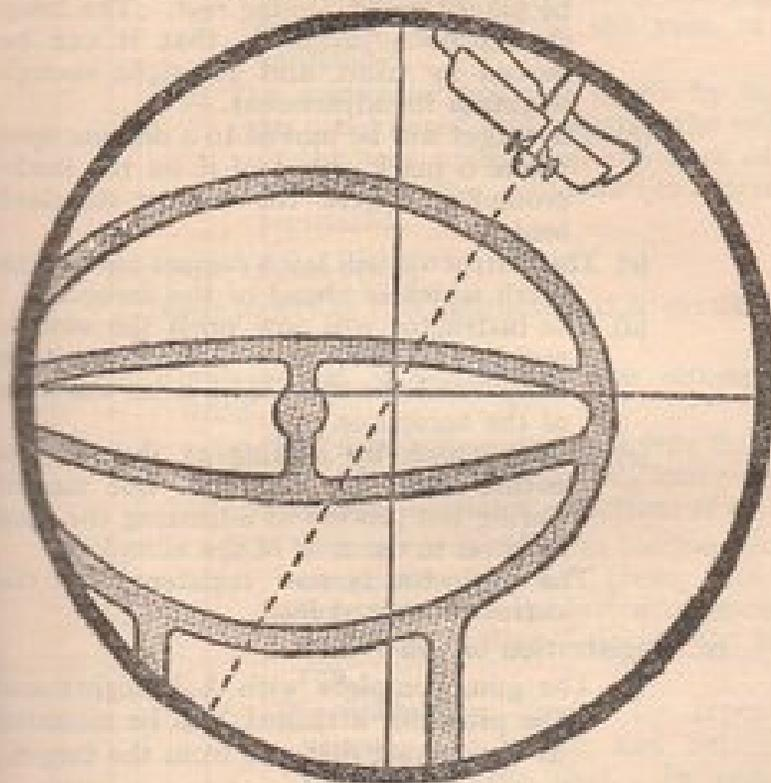
The Spotlight Projector

54. *Spotlight projector—Rifle and light automatic*
(See Appendix X)

1. Preliminaries.

- i. *Stores required.*—Projector apparatus complete; rifle, aiming rest, gun, with A.A. sights and mounting holder; A.A. mounting.
- ii. Rifle or gun placed at a distance from the target which will be governed by the necessity for having a clearly defined spot light on the screen background, and for utilizing to the utmost the available run of the target to teach the swing of the rifle or gun. If the distance chosen is too close to the target, the spot light and correct lead will be distorted at the extremities of the target run; whilst if too far away, the arc through which the rifle or gun should be swung will be too short. Mark the selected spot for the mounting or rest.

PLATE 22
EITHER RING IN USE



Incorrect.—The aeroplane is not flying towards the centre bead, the nose is not touching the outer edge of either ring, and the points where the nose of the aeroplane would touch either ring are not in the centre of the back-sight. The bullets will pass in front and to the left.

iii. Registration of rifle :—

- (a) The rifle, with the projector attached, will be placed on an aiming rest. The lamp should be adjusted so that it can be moved by hand, and yet tight enough to retain its adjustment.
- (b) The target will be moved to a definite spot where a mark ahead of it on the background will give the correct standard lead.
- (c) The instructor will lay a correct aim at the mark which is ahead of the aeroplane.
- (d) The instructor will now press the switch, and keep it pressed, while he moves the lamp until the spot light is on the nose of the aeroplane.
- (e) Finally check by looking at the aim, to ensure that the rifle was not moved during the process of adjusting the spot light on to the nose of the aeroplane. The projector is now registered for the correct standard lead.

iv. Registration of gun :—

- (a) The gun, complete with A.A. sights and the projector attached, will be mounted at the correct distance from the target.
- (b) The target will be moved to a position in the centre of its run.
- (c) Any one who is known to be able to lay an accurate aim, will be called upon to take a correct aim at the target.

(d) He will hold this correct aim, while the instructor presses the switch and adjusts the spot light on to the nose of the aeroplane.

(e) The instructor will now check by laying an aim himself and pressing the switch. If the spot appears on the nose of the aeroplane, the projector is correctly registered.

2. *Sequence of instruction.*

i. State object of this instruction is to give further practice in aiming.

ii. *Rifle.*—Squad will now practise aiming and firing.

(a) The firer will remove the rifle from the rest, assume the standing load position, and go through the motions of loading.

(b) The target will be set in motion and the command "Fire" given. He will fire every time the instructor gives the command "Fire" during the target run.

(c) The instructor checks by repeatedly pressing the switch and noting the position of the spot. In order to discover whether the man is disturbing his swing when pressing the trigger, the instructor should endeavour to manipulate the switch immediately the trigger is pressed. The spotlight

projector can also be used with a stationary model aeroplane in any position to check the man's aim and convince him of an error.

- iii. *Light automatic.*—Squad practises aiming and swinging with the gun. Instructor checks by repeatedly pressing the switch during each run.

TESTS OF ELEMENTARY TRAINING

55. *Standard tests*

The rifle

1. The model aeroplane will be mounted ten yards from the centre of the aiming rest. The man will lay four aims at the model, the position of which will be altered for each aim. One aim will be taken at a *climbing or diving* aeroplane and three aims at *crossing* aeroplanes (of which only one is to be *crossing directly*).

The instructor will check the aim by means of the rod and rectangle in the case of the crossing aeroplanes, and the point of aim must be within the rectangle. For a diving or climbing aeroplane, the aim must be absolutely accurate.

Standard.

- i. Three out of four aims to be correct.
- ii. Man must set his sight at 600 yards.

No time limit.

For description of model aeroplane and rectangle, see Appendix X.

The anti-aircraft light automatic

2. *Aiming.*—The gun will be mounted at the correct distance from the model aeroplane, *i.e.* ten yards. The man will load, aim and fire at the model, the position of which will be altered for each aim. One aim will be taken at a *climbing or diving* aeroplane and three aims at *crossing* aeroplanes, of which only one is to be *crossing directly*.

The instructor will check the aim with an aim corrector.

Standard.—Three out of four aims to be correct.

No time limit.

3. *Action from limber.*—The gun, complete with A.A. sights and holder, and the holdall, magazine carrier containing four magazines, and the A.A. mounting will be on top of a stationary limber. The gun numbers will be in rear of the limber. A model aeroplane on a pole will be set up at the correct distance, *i.e.* ten yards from the spot where the gun is to come into action.

The instructor will indicate the spot where the gun is to be mounted. This will be five yards from the limber. On the command "**Aircraft Action**," the gun numbers will perform their duties in bringing the gun into action as laid down in Sec. 52, 8. The No. 1 will load, aim at the model aeroplane using the outer ring, and fire. The instructor will check the aim with an aim corrector.

Time.—Fifteen seconds from the command "**Action**" until No. 1 presses the trigger.

To pass, all points of training must be correctly carried out. The aim must be correct.

Should No. 1 not have pressed the trigger with a correct aim within the limit owing to a faulty manipulation by the other gun numbers, he will be allowed another attempt.

4. *Recognition*.—From a set of silhouette diagram cards, the instructor will select any four. Each card shows two aspects of the same machine, one diving directly at the observer and one crossing direct from right to left. The selected cards will be exposed in turn for a period of five seconds. The men under test will be seated four yards distant from the cards, and after each exposure will write down the type of the machine.

Standard to pass.—Three out of four must be correctly named.

APPENDIX I

DESCRIPTION AND EXAMINATION OF THE '303-INCH LEWIS MACHINE GUN. MARKS I AND II

1. Nomenclature

1. The following is the nomenclature of the parts of the gun :—

Barrel.—With *barrel mouthpiece** and *band* for attachment of *gas chamber*.

Body.—With *ejector* and *ejector cover*; *body locking pin*; *pinion casing hinge pin*; and *safety catch plates*, left and right.

Body cover.—With *cartridge guide with spring*; and *magazine stop pawls*, No. 2, right, and No. 1 left, and *spring*.

Bolt.—With two *extractors* and *feed arm actuating stud*.

Butt.—With *Mk. I. butt cap and screw* or *Mk. I* butt cap and three screws*; *butt plate and two screws*; *butt swivel and four screws*; and *oil bottle*.

Clamp ring.—With *screw and foresight*.

Feed arm.—With *pawl and spring*; and *latch*.

Gas chamber.

Gas regulator.—With *key*.

Handle, cocking.

* Or *flash eliminator with locking collar*.

Pinion casing.—With *pinion*; *return spring* and *casing*; *hub*; *tension screw*; and *pinion pawl*, *axis pin*, and *spring*.

Piston rod.—With *rack* and *fixing pin*; *striker* and *fixing pin*.

Radiator.

Radiator casing.—*Front*, with *band* and *sling swivel*; and *rear*.

Tangent sight.—With *axis pin*, *washer* and *split pin*; *leaf*; *spring*; *slide*; and *elevating screw* and *milled head*, *keeper pin* and *check spring*.

Trigger guard and pistol grip.—With *trigger*, *trigger axis pin*; *trigger spring*; *plunger*; *sear*; *sear axis pin*; *butt catch* and *spring*; and *butt catch fixing pin*.

2. The following is the nomenclature of the parts of the magazine:—

Magazine.—With *pan*; *separating pegs*; *centre disc*; *centre block*; and *catch* with *spring*.

2. General description

1. Dimensions.

Weight of gun, about 26 lb.

Length of gun, 50½ inches.

Length of barrel, 26½ inches.

Number of grooves, 4.

Twist of rifling, right-handed.

Weight of magazine empty, 1½ lb.

Weight of magazine full, 4½ lb.

Weight of canvas carrier pouches, magazines and braces (set), 3 lb. 14 oz.

Weight of mount, field, Mk. III, about 2½ lb.

The gun is worked automatically by two forces: (1) The pressure of the gas resulting from the explosion of the charge; (2) the return spring.

The gun is divided into two portions, the stationary portion and the moving portion.

Stationary portion

2. The stationary portion consists of:—

i. The barrel group.

ii. The body group.

3. The barrel group consists of:—

i. The barrel, which at its front end is threaded in the reverse direction to the rifling to take the *barrel mouth-piece*.* The latter serves to keep the *radiator* in position on the barrel and to direct the gases outwards on to the *front radiator casing*, thus drawing cold air through the casing and tending to reduce recoil. At a point 4 inches from the muzzle a *gas-vent* is bored through the bottom of the barrel to allow a portion of the gases to pass into the *gas chamber*. A *band*, encircling the barrel and carrying a *boss* tapped internally for the reception of the threaded part of the *gas chamber*, is provided to connect the *gas chamber* to the barrel. At its rear end the barrel has a square thread for the attachment of the *body*, and immediately in front of this is a *stud* which enters a *slot* in the *radiator* and ensures that barrel and radiator are in their proper relative positions.

On the rear face of the barrel are *projections* which

* A *flash eliminator* with locking collar may be fitted in place of the *mouth-piece*.

support the base of the cartridge, and a *groove* which assists to guide the bullet into the *chamber*.

ii. The *radiator* which surrounds the *barrel* is of aluminium with projecting *flanges* which, by increasing the area exposed to the air, assist in dissipating the heat of the *barrel*. Underneath, towards the front end, is a *recess* to allow the assembly of the *gas chamber*, and at the rear, the *radiator* ends in a *flat* over which a corresponding flat surface on the *radiator casing* lies, thus keeping both in position.

iii. The *radiator casing* is in two parts. The *rear* portion is cylindrical and bored to allow the *gas regulator* to pass through it. About 4 inches in rear of the *gas regulator* is a hole, with a raised edge, for the *stud* of the *gas regulator key* when the latter is sprung into position. On the upper side at its rear end the radiator casing forms a flat surface to engage with a similar surface on the *radiator*, and beneath this, through the end face, are holes for the *barrel* and *gas cylinder*, also a recess for the front of the *body locking pin*, and a *flange* to assist in locking the *body*.

The *front radiator casing* tapers to a reduced diameter, and projects beyond the *barrel mouthpiece*. A fitting for a *sling* fits on to the *front radiator casing* just in front of the *radial shoulder*. It consists of a *band* which has an opening at the lower end to receive a *swivel* for the *sling*. A *clamping screw* serves to secure the *band* and also acts as a pivot for the *swivel*.

iv. The *clamp ring* joins the two portions of the *radiator casing*, a *stud* on the inner surface of it engaging with suitable *recesses* in both portions. The ends of the *clamp ring* are turned up to form *protecting wings* for

the *foresight*, the inner portion of the right wing forming the *foresight block*, with a dovetail *groove* for the reception of the *foresight*. The *clamp ring screw* passes through both wings and holds the *ring* in position. The latest *screw* (No. 2) is $\frac{1}{4}$ inch longer than the original pattern (No. 1) and its head is of smaller diameter. It was introduced to facilitate the removal and reassembling of the *clamp ring* and *front radiator casing*, as with this *screw* the *clamp ring* can be opened out sufficiently without completely unscrewing the *screw* from the threaded portion of the *clamp ring*.

The *foresight* is of blade pattern.

v. The *gas chamber* screws into a *boss* on the *barrel band*, and its *nipple* enters a recess in the *barrel* at the *gas-vent*. Its rear face is drilled to communicate with the *gas cylinder*, which screws on to this part. Underneath, the *gas chamber* is open and is tapped to receive the *gas regulator*. It is provided with two *wings* for the engagement of the *spanner* used in stripping.

vi. The *gas regulator* screws into the *gas chamber* and has two circular holes, either of which can be turned so as to correspond with the hole in the rear face of the *gas chamber*.

As one of these holes is slightly larger than the other, the amount of gas which is allowed to pass into the *gas cylinder* can be varied and the power increased or decreased slightly at will. The letters "L" and "S" on the head of the *gas regulator* indicate the position of the holes. The head of the *gas regulator* has a rectangular hole into which the squared portion of the *gas regulator key* fits. The other end of the key has a *stud* which springs into the corresponding hole in the *rear radiator*

casing and prevents the *regulator* turning, while a loop is provided which enables the point of a bullet or *combination spring balance* to be used to disengage the *stud* and free the *key*.

vii. The *gas cylinder* is of steel, and is tubular, the bottom part being shaped at the rear end to allow the *rack* on the *piston rod* to enter. Its front end screws on to the *gas chamber*, and its rear end fits into the end face of the *rear radiator casing*.

4. The body group consists of:—

i. The *body* screws on to the *barrel* and is retained in position by the *body locking pin* which is housed on the underside of the front end of the *body*. This *pin* has *grooves* cut into it to allow of its being pushed forward or backward with the point of a bullet for stripping purposes. A *slot* is cut in the side of its housing for the insertion of the point of the bullet. In rear of the housing is the *pin* on to which the *pinion casing* hooks. The underside of the *body* has openings cut in it to allow of the entry of the *pinion*, of the *plunger* and of the *sear*, and it has *guides* for the reception of the *trigger guard*, which has corresponding *guide grooves*.

In rear of these is a transverse *groove* into which a corresponding *projection* on the *butt cap* enters.

On either side of the *body* are *slots* in which the *shank* of the *cocking handle* travels. The *cocking handle* can thus be used on whichever side of the gun may be more convenient. *Sliding plates*, each having a *finger piece*, are provided to close the *slot* which is not in use.

Recesses in these *plates* make them also a safety

device as, if the *plate* on the side on which the *cocking handle* is inserted be raised, the *recess* engages with the *shank* of the *cocking handle*, preventing it and the *piston* from moving. The rear *recess* is undercut for the purpose of preventing the *side plate* from being lowered should the *trigger* have been pressed with the *safety catch* up. On the right side of the *body* is the opening for ejection of empty cases.

The top of the *body* is flat. At its front end is the *magazine post*. The interior of the *post* is a hollow *cone* which, when the *magazine* is placed in position, disengages the *magazine catch* and frees the outer *pan* from the *centre disc*. Below the *cone* on the left side is a *recess* with which the *hook* of the *magazine catch* engages. The *post* has on its exterior a *key* which serves to keep the *centre block* of the *magazine* from rotating: it has also a *saw cut* which engages the *feed arm latch* and prevents the *feed arm* jumping.

The top of the *body* is slotted longitudinally, the *slot* at its front end taking the shape of the outline of a cartridge, while the rear portion acts as a guide for the *boss* on the *feed arm actuating stud*. In the *slot* are two small *shoulders* which prevent the cartridge dropping into the *body* when it is in position. On the left of this *slot* is the *ejector seating*. The *ejector* is hook-shaped and is pivoted on a *stud* on its under surface which enters a hole in the bottom of the *seating*. *Slots* are cut into the interior of the *body* which allow the head and tail of the *ejector* to project alternately into the *bolt way*. The *ejector seating* is closed by a sliding *spring cover*. The upper surface of the *body* is provided at its rear end with a shallow *groove* in which runs the *stud* on the tail of the

feed arm, and has various *projections* and undercut portions which retain the *body cover* in position.

Internally the *body* is drilled longitudinally for the *bolt* and the *piston rod*. The *boltway* at its rear end is cruciform, the arms of the cross forming *guideways* for the *lugs* on the *bolt* and on the *feed arm actuating stud*. *Recesses* in them serve to retain the *bull cap* when rotated into position. At the front end of these *guideways* are *recesses*. When the *bolt* is rotated the *lugs* on its rear end enter these *recesses*, which take the shock of discharge.

The channel for the *piston rod* is flat bottomed to accommodate the *rack*.

ii. The *body cover* is shaped to fit on top of the rear portion of the *body*. At its front end is a projecting *tongue* on the underside of which is the seating for the *cartridge guide*. Under the front part of the *cover* proper are the *axis studs* for the two *stop pawls*. *Projections* are provided on either side which engage with similar surfaces on the *body* and hold the *cover* in position.

The *cartridge guide* is held in position by an *undercut recess*, and has a *stud* which fits in a hole in the *tongue*. The acting lip of the *guide* is hinged and operated by a *flat spring*.

The *magazine stop pawls* pivot on *studs*, the No. 2 *pawl* on the right fitting underneath the No. 1 on the left. The *head* of the No. 2 is enlarged to bring it level with the underside of the *cover*.

The *stop pawl spring* lies behind the *pawls*, and a *stud* on its back fits in the *rib* behind it. Part of the left of the *spring* is turned over to embrace the *right stop pawl*.

On the upper surface is the *backsight bed*, carrying the

tangent sight leaf hinged at its rear end, and a *flat spring* to hold the *leaf* in position. The *bed* is fixed by a *screw*.

iii. The *tangent sight* consists of a *leaf*, on the *uprights* of which the graduations are marked, and a *slide* which works between the *uprights*. This *slide* is of *aperture* pattern. At the back of the right-hand *upright* is the *elevating screw*, which passes through the *slide* and is operated by a *milled head*. On the under surface of the *milled head* are *recesses* which engage with the *rib* of a *small check spring* housed in the upper end of the *tangent sight leaf*; these *recesses* prevent the *slide* moving from the position at which it is set.

iv. The *pinion casing* is shaped to contain the *pinion* with its enclosed *spring*. At its front end is the *hook* which engages it to the *body*; this *hook* is recessed at its front end to allow of the removal of the *pinion casing* without disconnecting the *body* from the *barrel*. At its rear end is the *pinion pawl* which prevents the *spring* unwinding when the *pinion* is not engaged with the *rack* (e.g. when the *pinion* and *casing* are allowed to drop prior to altering the tension of the *spring* or when the gun is being stripped). The *downward arm* of this *pawl* has a *rib* which engages with the *pinion*, and behind this *arm* is a *wire spring*. The horizontal *arm* of the *pawl* projects from the *casing* and is lifted by the front end of the *trigger guard* as the latter is slid into position.

The assembling of the *trigger guard* thus removes the *rib* on the *downward arm* of the *pawl* from engagement with the *teeth*. In this way it leaves the *pinion* and *spring* controlled by the *rack*. The sides of the *casing* are drilled to take the *tension screw*, with two flanges to retain the head of the *screw*.

v. The Mark I or Mark I* *trigger guard and pistol grip* consists of a frame which is channelled to contain the *plunger, trigger, sear* and *butt catch*, while it is extended downwards to form the bow of the *trigger guard* and the *pistol grip*. Externally, the frame has *guide grooves* to connect it with the *body*, while at its front end is the *recess* for the arm of the *pinion pawl*. In the channel lies the *plunger*, which acts as a cover for the *trigger spring*. In the side of the plunger is a *slot* for the front end of the *trigger*. The *trigger* is pivoted on its *axis pin*, with its front *arm* engaging the *plunger* and its *rear arm* forming a *jaw*. The front end of the *sear*, Mark I, is engaged in the *jaw* of the *rear arm* of the *trigger*, while the *block* at its rear end forms the *nose* of the *sear*. The *sear* also is pivoted on an *axis pin*. At the rear end of the channel is the *butt catch* in the interior of which is its *spiral spring*, the whole being kept in position by a *fixing pin*. The *butt catch* has a *tooth* projecting downwards which engages with a *recess* in the *butt cap* when the latter is rotated into position.

The No. 2 *catch* has a projecting *thumbpiece* to enable it to be disengaged without the aid of a cartridge.

The Mk. I* *trigger guards* differ from the Mk. I in that the wood side pieces of the *pistol grip* are attached by means of a *screw* and steel bushes.

vi. The *butt* performs the function of closing the rear end of the *body*. It is of wood and shaped like the butt of a rifle. It carries on its front face the *butt cap*, which acts as a stop for the *bolt* and *piston rod*, and serves to keep the *body cover* from working backwards.

The *butt cap* is provided with projections for attaching it to the *body*, and a recess is provided in the lower one

into which the *tooth* of the *butt catch* enters, locking the whole in position.

An *oil bottle* with *milled head* and *oil brush* is fitted vertically through the thick part of the *butt*. A *sling swivel* is fitted just forward of the *oil bottle* on the underside of the *butt*.

Moving portion

5. The moving portion consists of :—

i. The *piston rod*, which is in two parts. A small amount of play is allowed at the junction to permit the *rod* to accommodate itself to any slight want of alignment between the *cylinder* and the *body*. The *head* of the *rod* is cupped and provided with *annular grooves*, the *rings* between which reduce to a minimum the passage of the gas past the *head*, tend to scrape away any *fouling* which accumulates, and minimize friction. The rear part of the *rod*, which is joined to the front portion by a *fixing pin*, is formed as a *rack* as regards its under surface, and in rear of the *rack* is the *beak* which engages the nose of the *sear*. On the upper surface of the *piston rod* is the *striker post*, which engages in the *camway* in the *bolt* and operates the mechanism. The upper end of the *post* is drilled longitudinally for the *striker*, which is secured by a *fixing pin*. A *slot* is cut through the *rod* towards the rear end to allow the *shank* of the *cocking handle* to enter. The *shank* is ribbed to make it grip the sides of the *slot* in the *body*.

ii. The *bolt*, which is cylindrical. Its *face* has a *rim* which supports the base of the cartridge and in which gaps are cut for the two extractors, which lie in longi-

tudinal *recesses* cut in the surface of the *bolt*. The *extractors* are flat *springs* with a *hook* on the *head* to engage with the rim of the cartridge and a *stud* which enters a *recess* in the *slot* in the *bolt*, and takes the pull of extraction. The *tail* is sprung into the rear end of the *slot*, which is grooved and thereby tends to keep the *hook* pressed inwards. Between the *recesses* for the *extractors* a *slot* is cut in the rim to allow the *head* of the *ejector* to enter. Behind the face, the *bolt* is hollow, and has a *cam-shaped slot*, in which the *striker post* travels. At the rear end of the *bolt* are four lugs, which take the shock of discharge, and it is here tapped internally to take the *feed arm actuating stud*. A *Mark II extractor* with a separate *spring* has been approved for future manufacture.

The *extractor* is shorter, and is stepped on its upper surface immediately over the circular *stud*; the shoulder thus formed is undercut, and forms an abutment for the front end of the *spring*. The *tail end* is tapered off to the rear, and the under corner at this end acts as a fulcrum on the surface of the *recess* in the *bolt* of the gun when the *hook* is raised against the pressure of the *spring*. The corners at the *hook* end are well rounded off.

The *spring* is similar in shape to the spring portion of the *Mark I extractor*, and its rear end is formed to fit into the "T" *slot* in the *bolt* in the usual manner.

iii. The *feed arm actuating stud* screws into the rear end of the *bolt*. It is prevented from turning by *lugs* which work in *guideways* in the *body* and by the *boss* on its upper part, which travels in the longitudinal *slot* in the top of the *body*, and which causes the necessary motion of the *feed arm*.

iv. The *feed arm* has at its front end the *axis hole* which passes over the *magazine post*, with a *recess* to clear the *key* on the *magazine post* when stripping or assembling.

A hinged *latch* secures the *feed arm* on the *post* by engaging in the *saw-cut* thereon. In rear of the *latch* is the *slot* through which the cartridge passes from the *magazine* to the *body*. This *slot* has a raised *stop* on the left side to hold the cartridge in position during the motion of the *feed arm* to the left. At the rear end of the *slot* are three *studs*, that on the right being the *axis stud* for the *feed arm pawl*, the one in the centre being a *stop* for the *pawl*, and that on the left being the *stud* for the *pawl spring*. The latter also presses the *right stop pawl* back during the motion of the *feed arm* to the right. The *feed arm pawl* is provided with a hole for the *axis stud*, and has a *slot* in which the *spring* lies. On its under surface is a *recess* in which the *stop stud* lies when the *pawl* is at rest, and also a *stud* for the loop at the end of the *spring*. The *spring* is of wire and is hook-shaped. The *tail* of the *feed arm* is curved, and its under surface is grooved to receive the *boss* on the *feed arm actuating stud*. At the end of the *tail* is a *stud* which engages with the top *lug* of the *bolt* when the latter reaches its limit of movement to the rear, thus holding the *feed arm* in position until the *boss* on the *feed arm actuating stud* again enters the *groove* in the *tail* of the *feed arm*.

v. The *cartridge guide* is housed in the *tongue* of the *body cover*. The *lip* which engages with the cartridge is hinged to the right side of the *body* of the *guide*. A *spring* is fitted into the *body* of the *guide*, the free end pressing downwards against the *lip*.

vi. The *magazine stop pawls* pivot on the *studs* under the front end of the *body cover*. The *left pawl* (No. 1) lies above the *right one* (No. 2), but the *head* of the latter is enlarged to bring it also level with the underside of the cover. The flat *spring* lies behind the *pawls*, with a *stud* on its back which enters a *hole* in the transverse *rib* behind it. A portion of the sides of the *left-hand arm* of the *spring* are turned over so as to embrace the *pawl*.

vii. The *pinion* is hollow with a central hole. Internally it has a shallow *recess* into which a corresponding *projection* on the *spring casing* enters, causing the two parts to move as one. The *spring drum* has a central *hub*, through which the *tension screw* passes, and to which one end of the *return spring* is attached. The other end of the *return spring* is made fast by two *studs* to the *rim* of the *spring casing*. The *return spring* is a flat-coiled *spring*.

viii. The gun is supplied with cartridges from a circular *magazine* holding forty-seven cartridges. There are various patterns of the Mark I magazine, differing in certain details. Of these, Nos. 5, 6 and 8 are only for ground service. The general principle of all patterns is that the *magazine* consists of a *pan* on whose *rim* are formed *rectangular indentations*. On the inner surfaces of these *indentations* are riveted, or welded, *plates*, which serve to hold the base of the cartridge. The centre portion of the *pan* is cut away, and over this hole is riveted a ring carrying 25 *pegs*, which hold the cartridges in position and, in conjunction with the *recesses* between the *indentations*, force them round as the *pan* is rotated. On the inner circumference of the *ring* and *pan* are 25 *recesses* for the *rib* on the end of the *magazine catch*.

Over the central hole is a steel *centre disc* in which is formed a *channel* for the *magazine catch* and *spring*.

Internally the *magazine* has a *centre block* with two *channels* cut in it in which the bullet ends of the cartridges lie. The two *channels* are joined by a *slope*, and a similar *slope* leads out from the lower *channel*. In its centre is a hole which forms the socket for the *magazine post* and in which is the *hook* of the *magazine catch*. A *keyway* is cut to engage the *key* on the *magazine post*.

In order to allow the *magazine* to be removed from the gun with one hand, when circumstances render such action necessary, a hole has been bored in the centre of the *band* at the lower or engaging end of the *catch* in latter supplies Nos. 5, 6 and 8 *magazines*, to which a leather bootlace, &c., can be attached. A convenient method for attaching the lace is to pass one end through the hole from the top, and to tie a knot in that end sufficiently large to prevent it from being drawn through the hole. The free end of the lace may be tied to form a loop to take the hand; the *catch* can then be released and the *magazine* removed from the gun simultaneously.

3. Examination of the gun

1. The following are the principal points to which attention must be paid in examining the gun. Except for the replacement of damaged parts from the parts provided as spare, repairs cannot as a rule be carried out by the section. The repairs, as well as the tests to be made by means of gauges, will be undertaken only by a qualified armourer.

2. Barrel.—See to the condition of *bore*, *rifling*, *lead*,

exterior and *gas vent*, and that the *projections* on the rear face and the thread on the *nozzle* are not damaged. The *barrel* should only be removed from the *radiator* for examination at infrequent intervals.

3. **Barrel mouthpiece.**—See that it screws up tightly to the *barrel*, and that the threads have not been crossed.

4. **Radiator.**—Examine this for indentations in the *flanges*, and see that the *barrel* fits properly.

5. **Rear radiator casing.**—Examine this for indentations and wear, especially at its forward end.

6. **Front radiator casing.**—Examine this for indentations, and that it fits into the *clamp ring* correctly; *sling swivel* not too loose.

7. **Clamp ring.**—See that it is firmly screwed up, and that it holds the *front radiator casing* rigidly.

8. **Foresight.**—See that it is in good condition and not loose.

9. **Gas regulator and gas chamber.**—Examine these for erosion and carbon deposit; see that they are not stuck. If they are, apply a little paraffin at the joint, and allow it to soak in to loosen the fouling or rust. If fouling has accumulated inside the *regulator*, it should be removed by means of the *gas regulator cleaner*.

See that the *gas chamber* is closely and firmly seated to the *barrel*; that the *screw threads* have not been overstrained; that the *gas holes* are not choked.

10. **Gas cylinder.**—See that the interior is clear of fouling and carbonised oil, and that the rear end is not cracked or split.

Examine the *screw thread* to see that it is not damaged, and the *bore* to see that it is not distorted or excessively enlarged by wear or cleaning. The examination of the *bore* need only be carried out when loss of gas power has been experienced, and then only by an armourer or artificer, in comparison with a new *gas cylinder*. It is not necessary for the face of the *gas cylinder* to abut on the *gas chamber*, and overturning is of negligible importance; enlargement of the *bore*, however, may have serious consequences. Other important causes of loss of gas power are friction in the *action*, escape at the junction of the *gas chamber* with the *barrel*, choking of the *gas hole* in the *gas chamber* and of the *gas regulator*.

A *cylinder* which is split at the end can be repaired by an armourer by brazing.

11. **Piston rod.**—See that the *fixing pin* joining the *piston rod* and the *rack* is not loose, that the teeth of the *rack* are not damaged, and that the *bent* is not worn or broken.

Examine the *striker post* to see that the working surfaces are not rough. Any roughness must be smoothed by the armourer with fine emery cloth. See that the *striker* is not damaged, and arrange occasionally with the armourer to test with the gauge for protrusion of the *striker point* through the *bolt*.

Examine the *cupped head* and *annular rings* for wear, and see that they form an effective gas check.

12. **Bolt.**—See that the edges of the *cam slot* are smooth. Any roughness must be removed by the armourer with fine emery cloth. The armourer should occasionally test the distance of the *boltface* from the

end of the *chamber* with .064-inch and .074-inch gauges, removing the *extractors* before using the latter gauge. A *bolt* which closes over the .074-inch gauge must be re-tested with a new *barrel*. If it still closes, it should be exchanged. If it passes this test, the worn *barrel* should be exchanged, but not the *bolt*.

13. **Pinion and casing.**—See that the teeth are not damaged or broken, that the *pawl* and its *spring* work correctly, and that the *axis pin* is secure.

14. **Return spring.**—See that it is not broken.

15. **Body.**—Examine this for excessive play in the *bayonet joint*, and at the joint with the *barrel* and *rear radiator casing*. In the latter case a *washer* or *washers* must be assembled, and the cartridge head space then re-tested. See also that the *body* is not fractured.

16. **Pinion casing hinge and pin.**—Examine these for wear.

17. **Safety catch.**—See that the *cocking handle* is securely held when the *safety catch* is raised. This should be tested on both sides of the gun.

18. **Feed arm.**—Examine the *latch* for weakness, the *axis hole* for play on the *magazine post*, the thin portion of the *arm* for bending or strain, the *stud* and *groove* for wear, the top of the *feed arm* for friction against the *ribs* on the *body cover*, the *pawl* for wear and the *spring* for weakness.

19. **Ejector.**—See that it is not broken or damaged.

20. **Body cover.**—See that the *pawls* and *spring* are undamaged, and that the *cartridge guide* is not weakened and is correctly assembled.

21. **Tangent sight.**—See that the *leaf* is not bent, that the *elevating screw* moves the *slide* correctly and is properly held by the *checking spring*, that the *aperture* is not damaged, and that the *fixing screw* of the *sight-bed* is not loose.

22. **Cocking handle.**—See that it is properly held in its slot in the *piston rod*.

23. **Trigger guard.**—See that the *nose* of the *sear* is not worn or broken. Wear of the *sear nose* or of the *bent on the rack* must be remedied by an armorer. See that the parts work correctly, and that there is no oil or dirt round the *plunger*, which would make the *sear* rise sluggishly.

24. **Butt cap.**—Examine this to see if it has been marked by the *piston rod* during recoil, and for security of fitting.

25. **Moving portions.**—See that they move freely, and that the *feed arm* is properly actuated by the *feed arm actuating stud*. Test the ejection with a few dummy cartridges. Place an empty *magazine* on the gun and work the *cocking handle* to see that the feed works correctly.

26. **Mounts, Field Mark III.**—Examine the *legs* for wear at the corner. Any excessively worn should be removed and replaced by new ones; the unserviceable ones being returned to store for factory repair.

27. **Magazines.**—Examine thoroughly and test for distortion.

28. **Spare parts and accessories.**—Should be examined in the same manner.

4. *Description of accessories*

1. **Box, battalion spares, Lewis .303-inch M.G. Mk. I.**—The box for battalion spares is a strong rectangular wooden box designed to carry the spare parts referred to in Sec. 5, which are held and fitted by the armorer.

2. **Cleaner, gas regulator.**—The *cleaner* is a steel tool with a wood handle; it is provided for removing fouling which has accumulated in the *gas regulator*.

3. **Handle, loading magazine.**—The *handle* is about 6 inches long. One end is similar in shape to the *magazine post* on the *body* of the gun. It is used when filling *magazines*. It is inserted into the underside of the *centre block* in such a way as to press the *magazine catch* out of engagement with the *recesses* on the *pan*, so allowing the *pan* to be revolved and filled.

4. **Plug, clearing, Mark I.**—The *clearing plug* is of steel, and is used for the removal of a separated case from the *chamber*.

The end of the handle is formed into a *jaw* for use as a hand extractor, to remove a live or empty cartridge from the *chamber*.

To remove a separated case, insert the *tapered portion* of the clearing plug, with the *centre pin* pushed back, into the *chamber*. Push the *pin* well home by allowing the *bolt* to go forward. Then, keeping a firm pressure on the *cocking handle*, give the *clearing plug handle* an up-and-down rocking motion, pull back the *cocking handle*; lever back the *handle* of the *plug*, and withdraw the *tapered portion* of the *plug* from the *chamber*. The front portion of the separated case will be found adhering

to it. Knock the *centre pin* back and remove the separated case.

5. **Washer, packing barrel.**—This *washer* is .005-inch thick, and is provided in order to take up the play which occurs between the *rear radiator casing* and the *body* in the case of guns in which the thread on the *barrel* has become worn.

The *washer* (or *washers*, as may be required) is assembled to the rear end of the *barrel* against the *flange*. It is secured in position by the *rear radiator casing* when the latter is assembled.

The fitting of the *washer* or *washers* should not prevent the *body* from being screwed home to the *barrel* and *rear radiator casing* by hand.

6. **Jack, screw, assembling and removing barrel.**—The *jack* is arranged to screw on to the *breech thread* of the *barrel* after the *collar* is inserted between the *jack* and the *radiator*.

When assembled in position for removing the *barrel*, the projecting *arm* of the *jack* is given a sharp blow. This action will loosen the *barrel* from the *radiator* and it can be then withdrawn.

The *jack* is closed at one end to form an anvil which may be struck with a hammer or other convenient implement, in order to drive the *barrel* home into the *radiator*.

Care must be taken to ensure that the *jack* is screwed right home to the face of the *barrel* before it is struck, as otherwise the thread on the *barrel* is liable to injury.

7. **Mount, field, .303-inch Lewis machine gun, Mark III.**—The *mount* consists of a *gun band* and two *legs*. The gun is held in the *band* by a *clamping screw*

and wing nut. It can be rotated when in position through an angle of 36 degrees to admit of the sight being vertical when on uneven ground.

The *legs*, which are of tubular steel, are telescopic and can be clamped at the desired height by *clamping screws*. Each *leg* has a *spike* and *hinged curved shoe*. When the *spikes* are embedded in the ground the *shoes* automatically *splay* out, owing to their curved shape, and give rigidity to the *mount* when in use. When not in use the *legs* can be folded under the gun and retained in that position by a *spring clip*.

8. Chest, Vickers or Lewis .303-inch machine guns, Mark II.—The *chest* is issued to take either Vickers or Lewis .303-inch guns with certain spare parts. Each chest is, however, so marked before issue as to show which type of gun it contains. It will take the Lewis gun, either with or without the *spade handle grip* (used in Air Service) assembled, but not with the *butt stock*, the latter being carried separately in the chest, but attached to the gun by a *sling*.

The lid is hinged and is fastened with two hasps and turn-buckles. A rope handle is attached at each end of the chest by a cleat. The chock, which is provided for the front end of the gun, is made reversible in order to meet the difference in size of the *radiator casing* of the Lewis gun and the *barrel casing* of the Vickers gun respectively. The central fitting in the bottom of the chest is hinged in order to provide a seating for the Lewis gun with or without the adapter for mounting the gun on Service mountings.

Mk. III chests differ from Mk. II in having a mild-steel strip in lieu of leather at the rear edge of the lid.

A modified chest is issued (1 per 4 guns) to carry certain additional spares for Lewis guns. This chest is stencilled "Guns Lewis .303 Mk. I & S."

The chests take the contents for the Lewis gun as shown on pp. 270 *et seq.* The *band radiator casing* is assembled to the gun with the *sling* attached.

The weight empty is about 38 lb.

The weight filled is about 83 lb. (including the adapter, when issued for use with the Mk. IV tripod mounting, weight 5 lb.).

9. Holdall, Lewis .303-inch machine gun, Mark I.—The holdall is provided for the spare parts and tools which are to accompany each gun.

It is approximately 31 inches long and 5 inches wide, its main features comprising a flat back or base with two closing flaps, secured by quick-release fastenings. The bottom end is formed as a pocket and is strengthened with leather.

Five additional pockets, each with flaps with quick-release fastenings, are arranged in line on the inside of the back, the upper pocket, to contain the leather wallet for immediate action parts, being accessible when the main flaps of the holdall are closed.

A further pocket for the cylinder cleaning rod is provided on the inside of one of the main flaps.

Provision is also made for the bore cleaning rod and the piston rod along respective edges of the back adjacent to the line of pockets above referred to, the handle of the former projecting beyond the upper end of the holdall, where it is secured by a quick-release fastening. A carrying handle is attached to the edge of the back. An adjustable sling is attached to the back.

The designation of the holdall is stencilled on the outer flap. Weight (empty) approximately 2½ lb.

10. **Cover, Lewis machine gun.**—The *cover* is made of khaki-coloured canvas, and is shaped to fit round the *breech* of the gun from the small of the *butt* to the *mounting ring* on the *rear radiator casing*.

It is closed along the top of the gun by five *quick releases*. Inside the left-hand side is a loose canvas *flap* which is placed under the right-hand side to exclude rain.

11. i. **Carrier, magazine, Lewis .303-inch machine gun, Mark I.**—The *carrier* consists of a cylindrical khaki-coloured canvas bag about 9 inches in diameter and 12 inches deep. A ring of cane is sewn round the bag about 5 inches from the base. Another similar ring, or disc, of wood or fibre is inserted in the base to stiffen the bag and provide protection for the magazines.

A loop of webbing is sewn round the bag vertically, the upper portion forming a handle for carriage.

At one side of this handle is a loose web strap with a buckle at the free end of it so that two carriers can be joined together and carried over the shoulders.

The bag holds four Mark I *magazines* and is closed by two turn-buckles and two eyelets.

ii. **Pouches, magazines, web and braces.**—Both articles are made throughout of woven web, and the buckles are of the tongueless pattern.

The *pouch* is designed to hold two *magazines*. It is circular in shape and is about 9 inches in diameter when closed. Four *pouches* form a set.

The *braces* are issued two to a set. Each consists of a strip of webbing 27¼ inches long and 2 inches wide.

The *pouches* and also the *braces* are interchangeable. **Instructions for assembling and fitting.**

The set consists of *two braces* and *four pouches*.

Fasten the ends of the *braces* to the 2-inch buckles on the *pouches* by first passing the end of the *brace* up through the top opening of the buckle, down through the centre opening, up through the bottom opening, and then under the top bar of the buckle.

When the *braces* (which must not be crossed) have been suitably adjusted, the back should be connected by fastening the 1-inch web strap of one *pouch* to the 1-inch buckle on the opposite *pouch* worn on the back.

The front *pouches* should be connected to the back *pouches* in a similar manner, the fastening being at either side of the wearer. The equipment when assembled as above is now ready to put on the wearer. It can be secured in front like an ordinary waistbelt by means of the web straps.

Carriage of the pouch and braces (see Appendix II).

iii. **Box, carriers, magazine.**—The *box* is made of sheet steel of the following dimensions: 19 inches by 10 inches by 7 inches. Internally it is divided in half by a partition. A pocket is provided in one corner for a *magazine loading handle*. The *lid* is hinged and is provided with a leather handle for carrying and is fastened by a *spring catch lock*. The Mk. I* box is fitted with "Fearnought" lining on the inside of the lid to prevent the entrance of dust and sand.

The box holds eight filled *magazines*, either in two *magazine carriers* or four *pouches* with *braces*.

12. **Spanner, barrel mouthpiece.**—The *spanner* consists of a flat piece of steel with *jaws* at one end to

fit the slots in the *barrel mouthpiece*. A *gap* is cut at the other end to take the *positioning stud* in the *clamp ring* of the Mark I guns.

13. Eliminator, flash, Mark I.—This consists of a hollow conical *mouthpiece*, bevelled off on one side at its outer end, and with its inner, or rear, end arranged similarly to that of the *barrel mouthpiece*.

A locking *collar* is supplied to secure it in the desired position. When assembled it projects about $4\frac{1}{2}$ inches from the muzzle of the *barrel*.

It is necessary to cut a *groove* in the front end of the *radiator* to take *projections* on the *locking collar*. This work will be carried out by duly qualified armourers or artificers in accordance with the instructional print No. A.I.D./1711.

To assemble the *eliminator* to the *barrel* the *locking collar* will be placed on the *barrel* with the inner *projections* fitting in the *grooves* of the *radiator*. The *eliminator* is then screwed on by means of the *spanner* and, when fully screwed on, one of the outer *projections* on the *locking collar* is bent to engage in one of the *recesses* on the *eliminator*.

14. Guns, machine, Lewis .303-inch, Mark I, skeleton.—A limited number of unserviceable Lewis guns have been cut to show certain parts of the mechanism which are normally enclosed when the gun is assembled.

15. Magazines, Mark I, skeleton.—Unserviceable, No. 6 or 8, Mark I, *magazines* may be cut, as shown in L. of C., para. 24946, for instructional purposes by duly qualified armourers.

16. Diagrams, large.—These diagrams are enlarged

drawings of certain parts of the gun, mounted on canvas for hanging on the walls of lecture or barrack rooms. These are a Stationery Office supply.

5. Complete set of equipment of the .303-inch Lewis machine gun, Mark I, for Infantry battalions only.†

	For ground Service Guns	For A.A. Guns
Gun, machine, Lewis .303-inch, Mk. I	1	1
Mounts, field, .303-inch, Lewis M.G., Mk. III	1	1
Chest, Vickers or Lewis .303-inch, M.G.	1	1
Holdall, Lewis .303-inch, M.G. Mk. I, Filled (for list of contents see Sec. 6, 2)	1	1
Braces, pouch, equipment	10	2
Boxes, carrier, magazine	4	7‡
Carriers, magazine	2	5
Cover, Lewis .303-inch, M.G.	1	1
Holder, Lewis .303-inch M.G. mounting, tripod, A.A.	—	1
Magazines	22*	10
Mounting, tripod, A.A. Lewis .303-inch M.G.	—	1
Pouches, magazine, web	20	4
Sights, A.A., Mk. II :—		
Back	—	1
Fore	—	1
Slings, Lewis M.G., web †	1	1
Aim corrector, Lewis .303-inch M.G., Mk. I	—	1

* 2 empty for each gun.

† Scale of equipment for other arms is laid down in the War Equipment Tables applicable to the units concerned.

‡ Woolwich section 1A.

§ 7 for 2 guns.

6. *Detail of spare parts and tools issued to infantry battalions*

1. **Gun Chests** (1 for each gun).

i. One chest in 4 contains:—

The gun, mounting, sling, cover, gloves, carrying handle and one spare barrel, one piston rod with gas cylinder, one jack assembling and removing barrel with collar and a No. 1 wallet containing:—

Boxes small parts M.G., No. 2, Mk. I	...	1
Cleaners, gas regulator, Lewis ·303-inch M.G., Mk. I.	...	1
Guns, machine, Lewis ·303-inch:—		
Extractors, Mk. II	...	4 (a)
Heads, screw, tangent sight	...	1
Pawls, pinion	...	1
Pins, head screw, tangent sight...	...	1
" pawl pinion...	...	2
" sear	1
" trigger	...	1
Sears, Mk. I	...	1
Springs head screw, tangent sight	...	1
" pawl feed arm	...	1
" " pinion	...	2
" pawls, stop magazine	...	1
" return	...	1 (c)
Guns machine, Lewis ·303-inch Mk. I:—		
Screws, clamp ring, No. 2	...	2 (b)
Screwdrivers small M.G., Mk. I	...	1

(a) Or Mk. I (Mk. II is supplied with spring).

(b) Or No. 1.

(c) With return spring casing and hub in tin box.

ii. The remaining chests contain the gun, mounting, sling, gloves, and carrying handle only.

2. **Holdalls** (1 for each gun), containing:—

1st or bottom pocket.

Can, oil, M.G., Mk. I 1

2nd pocket.

Brushes, rod, cleaning, cylinder, Lewis ·303-inch M.G., Mk. I 2

Mops, rod, cleaning, cylinder, Lewis ·303-inch M.G., Mk. I 2

Pull-throughs, double, Mk. I "A" ... 1(2 on Mob.)

3rd pocket.

Box, small parts, M.G., No. 2, Mk. I ... 1
containing:—

Guns, machine, Lewis ·303-inch:—

 Handles, cocking, No. 1 1

 Pins, sear 1

 " trigger 1

 " fixing striker 2

 " locking body 1

 Regulators, gas, Mk. I... .. 1

 Springs, pawls, stop magazine ... 1

 Strikers 1

 Pull-throughs:—

 Gauze... .. 2(4 on Mob.)

 Springs, return (with casing and hub in tin box) 1

4th pocket.

Guns, machine, Lewis, ·303-inch:—

 Covers, ejector 1

 Keys, gas regulator 1

Handles, loading magazines, Lewis .303-inch M.G., Mk. I	1
Punches, No. 3, M.G., Mk. I	1 (or No. 4 M.G., Mk. II)
Spanners, Lewis .303-inch M.G., Mk. I				1
<i>5th pocket.</i>				
Wallet, Lewis .303-inch M.G. No. 2, filled	1
containing:—				
Balances, spring, combination, Lewis .303-inch M.G., Mk. I	1 (b)
Boxes, small parts, M.G. No. 2, Mk. I	1
Guns, machine, Lewis .303-inch:—				
Bolts	1
Casings, pinion, assembled	1
Ejectors	1
Extractors, Mk. II	2 (a)
Guides, cartridge	2
Handles, cocking, No. 1	1
Pawls, feed arm, Mk. I*	1 (c)
" stop, magazine, No. 1, left, Mk. I*	1 (c)
" " " No. 2, right, Mk. I*	1 (c)
Pins, locking body	1
Springs, pawl, feed arm	2
" pawls, stop, magazine	1
Plugs, clearing, Lewis .303-inch M.G., Mk. I	1

Reflectors, mirror, .303-inch M.G., Mk. I	1
(a) Or Mk. I (Mk. II is supplied with spring).				
(b) Or Balance, spring, M.G., Mk. I.				
(c) Or Mk. I.				

Miscellaneous.

Rods, cleaning, cylinder, Lewis .303-inch, M.G., Mk. I	1	Pocket on flap
Rods, cleaning .303-inch, M.G., Mk. II	1	Stem through long pocket with eye end home in 1st pocket
Rods, piston, No. 2 or No. 1	1	Rear end in 1st or bottom pocket, front end in fastening

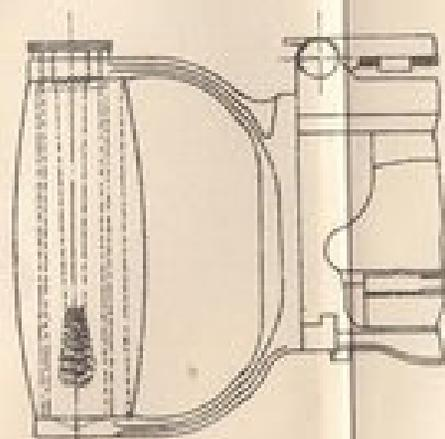
3. Box battalion spares (1 for each battalion)
containing:—

Box, small parts M.G., No. 1, Mk. I	1
Guns Machine Lewis .303-inch:—				
Bands, barrel	4
Blades, foresight, High	4
" " Low	4
Springs, trigger	2
Triggers	2
Washers, packing, barrel	6
Guns, Machine Lewis .303-inch, Mk. I:—				
Butts, Mk. II, normal	4
Caps, Butt Mark I*	4
Screws, butt cap	4

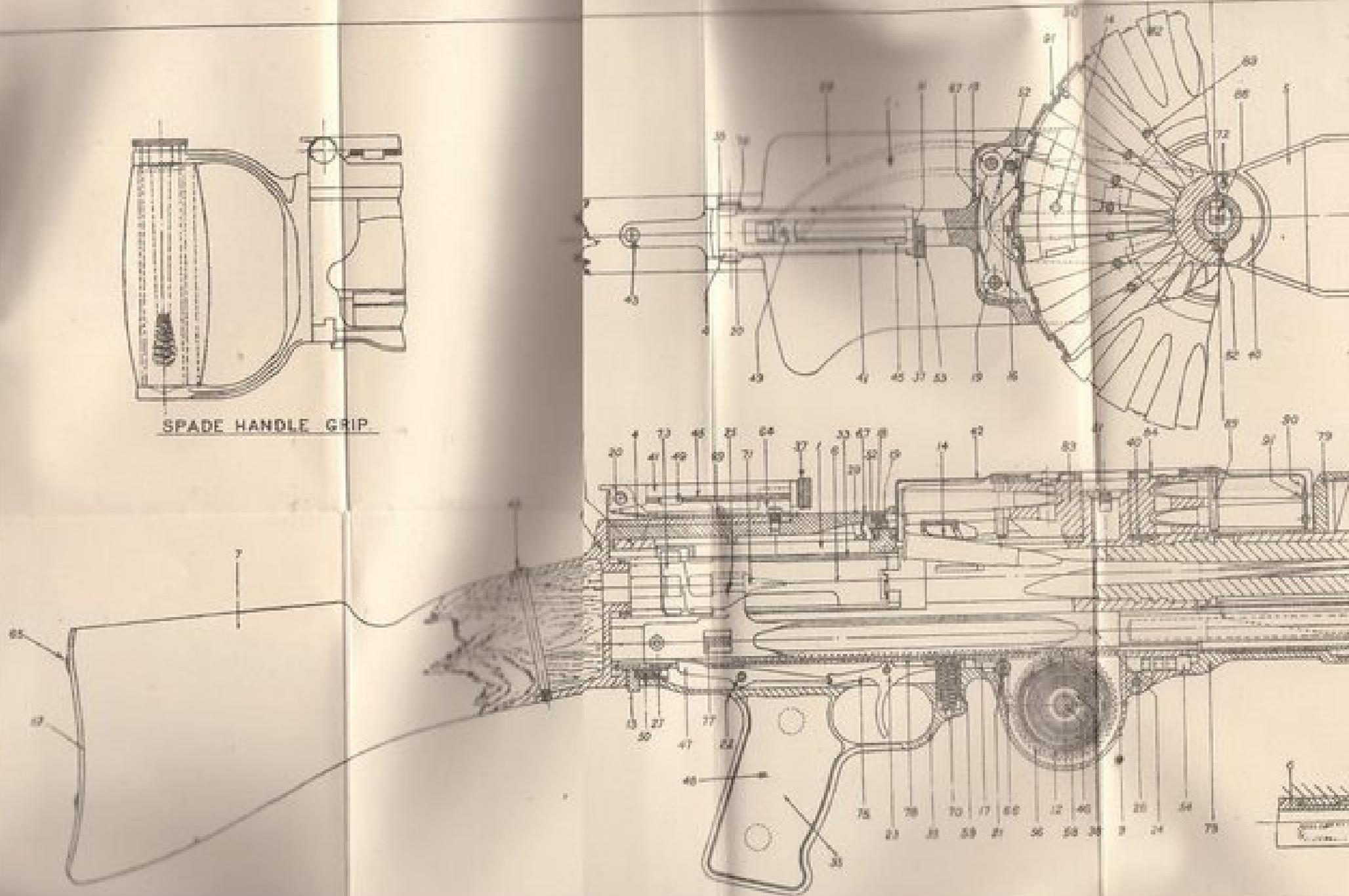
7. List of component parts (see Plate 23)

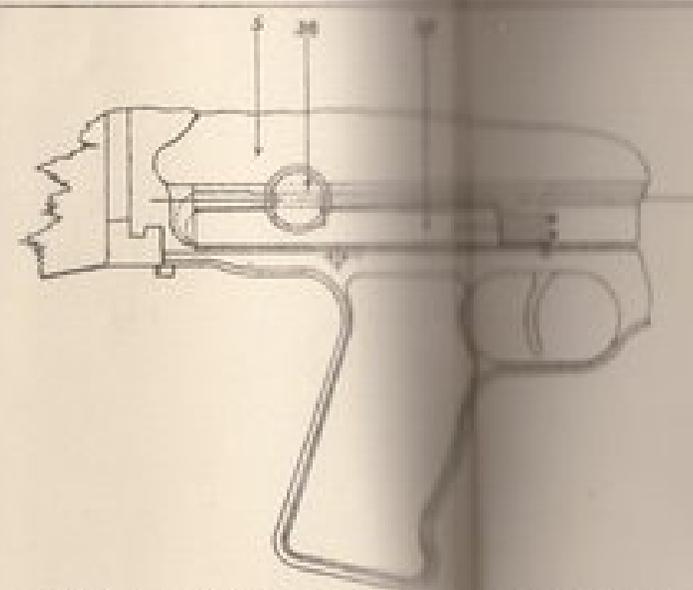
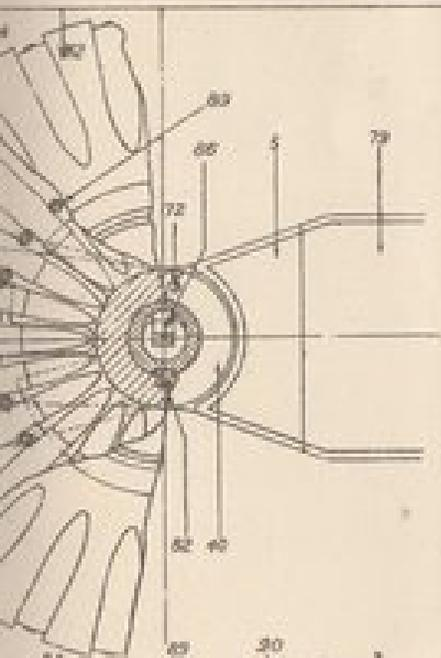
(.303-inch Lewis machine gun)

1. Arm, feed (with latch).	35. Guard, trigger (and pistol grip).
2. Band, barrel.	36. Handle, cocking.
3. Barrel.	37. Head, screw, elevating tangent sight.
4. Bed, tangent sight.	38. Hub, return spring.
5. Body.	39. Key, gas regulator.
6. Bolt.	40. Latch, feed arm.
7. Butt.	41. Leaf, tangent sight.
8. Cap, butt.	42. Magazine.
9. Casing, pinion.	43. Screw, butt cap.
10. " radiator, front.	44. Screw, clamp ring.
11. " " rear.	45. " elevating, tangent sight.
12. " return spring.	46. " tension, return spring.
13. Catch, butt.	47. Sear.
14. Guide, cartridge.	48. { Side-piece, pistol grip, right.
15. Mouthpiece, barrel.	48. { Side-piece, pistol grip, left.
16. Pawl, feed arm.	49. Slide, tangent, sight.
17. " pinion.	50. Spring, butt catch.
18. " stop magazine, No. 2, right.	51. " head, screw, tangent sight.
19. " stop, magazine No. 1, left.	52. " pawl, feed arm.
20. Pin, axis, leaf, tangent sight.	53. Pin, fixing, head, screw, tangent sight.
21. " " pawl, pinion.	54. " locking body.
22. " " sear.	55. " split, keeper, axis pin, tangent sight.
23. " trigger.	56. Pinion.
24. " fixing, rack, piston rod.	57. Plate, butt.
25. " striker.	58. { " safety catch, right, Mk. I*.
26. " hinge, pinion, casing.	58. { " safety catch, left, Mk. I*.
27. " keeper, butt catch.	
28. Chamber, gas.	
29. Cover, body.	
30. Cover, ejector.	
31. Cylinder, gas.	
32. Ejector.	
33. Extractors (2).	
34. Foresight.	



SPADE HANDLE GRIP





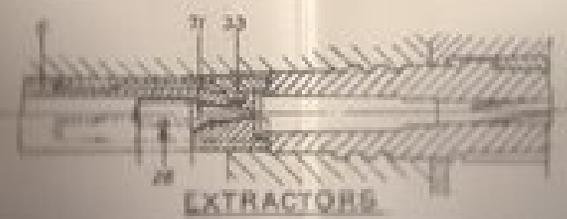
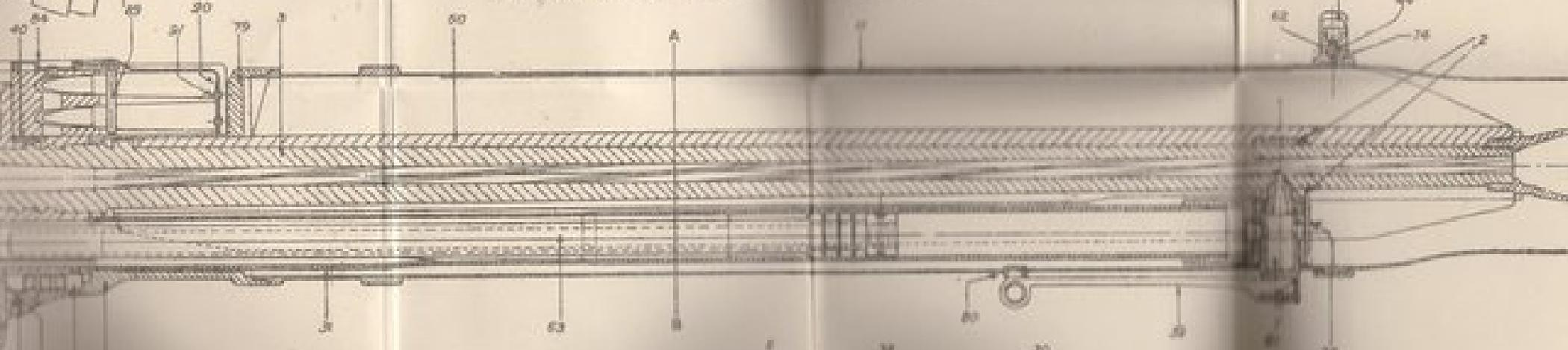
COCKING HANDLE & SAFETY CATCH PLATE.



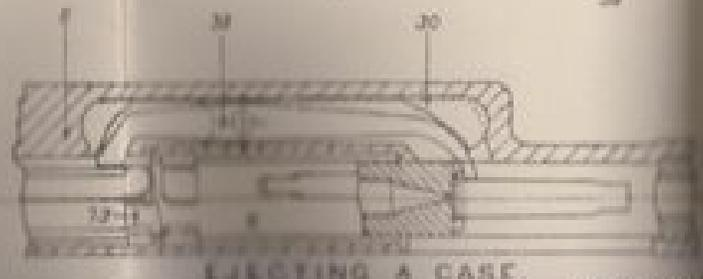
MAGAZINE CATCH AND CENTRE DISC.



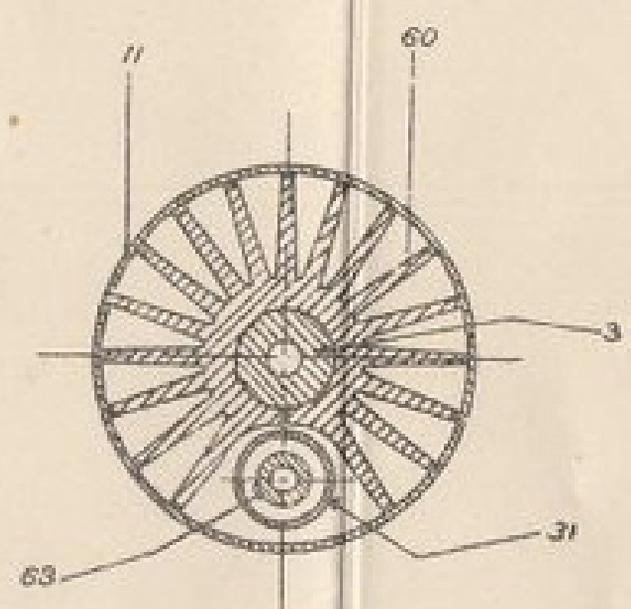
SECTION



EXTRACTOR.

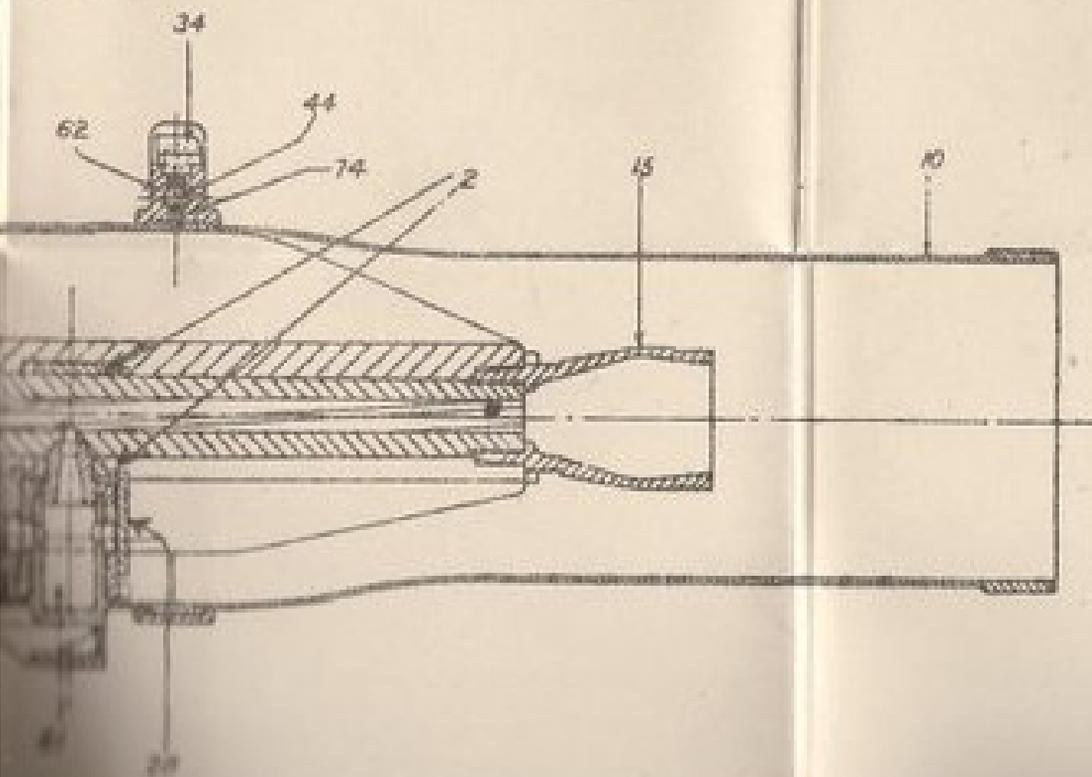


EJECTING A CASE.



ATCH AND DISC.

SECTION THROUGH A.B.



- | | |
|--|--|
| 59. Plunger, spring, trigger. | 68. Spring, return. |
| 60. Radiator. | 69. " tangent, sight. |
| 61. Regulator, gas. | 70. Spring trigger. |
| 62. Ring, clamp. | 71. Striker. |
| 63. Rod, piston. | 72. Stud, axis, latch, feed arm. |
| 64. Screw, bed and spring,
tangent sight. | 73. " actuating, feed arm. |
| 65. " butt plate. | 74. " positioning, clamp,
ring. |
| 66. Spring, pawl, pinion. | 75. Trigger. |
| 67. " paws, stop, maga-
zine. | 76. Washer, pin, axis, tangent
sight. |

The following are also shown in Plate 23 :—

- | | |
|---|---|
| 77. Slot, cocking handle. | 86. Magazine catch. |
| 78. Rack. | 87. " " spring. |
| 79. Locking piece, rear radia-
tor casing. | 88. Ring, with separating pegs
and recesses for nib of
catch. |
| 80. Stud on gas regulator key. | 89. Separating pegs. |
| 81. Magazine post. | 90. Cartridge head retaining
plates. |
| 82. Key on magazine post. | 91. Rivets for retaining plates. |
| 83. Magazine centre block. | |
| 84. " " disc. | |
| 85. " " disc rivet. | |

APPENDIX II

METHOD OF PACKING THE LIMBERED G.S. WAGON WITH LEWIS GUNS OF A COMPANY, AND DRILL FOR LOADING AND UNLOADING IN WAR

1. One limbered G.S. wagon is allotted to each company for carrying the 8 Lewis guns with their equipment and certain other items for the use of the company.

2. The items carried on the company limber (Plate 24) are as follows:—

*Fore portion.*i. *Lewis gun equipment*

Lewis machine guns with cover, mounting, sling and carrying handle	4	} in 4 gun chests
Machine gunners' gloves, pairs	4	
Spare part holdalls	4	} Carried in 16 magazine boxes each with loading handle
Filled magazines	80	
Empty magazines	8	
Magazine pouches	80	
Braces	40	
Magazine carriers	8	

ii. *Ammunition not in magazines.*

Boxes of carton packed S.A.A. 2

iii. *Other company items carried.*

Pickaxes	2
Shovels	2

To face page 269

45.

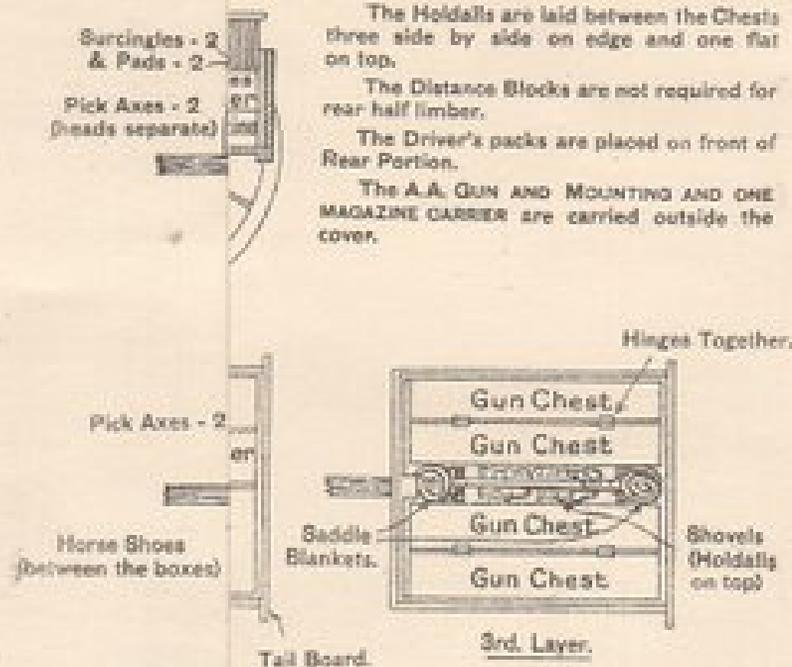
REAR PORTION.

The Holdalls are laid between the Chests three side by side on edge and one flat on top.

The Distance Blocks are not required for rear half limber.

The Driver's packs are placed on front of Rear Portion.

The A.A. GUN AND MOUNTING AND ONE MAGAZINE CARRIER are carried outside the cover.



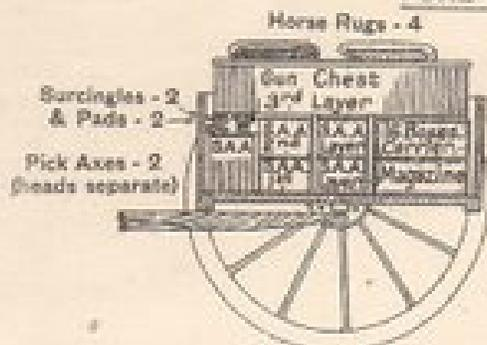
D/104,302/0029,2072

Malby & Sons, Ltd.

PLATE 24.

PACKING OF LIMBERED G.S. WAGONS WITH LEWIS GUNS.

FORE PORTION

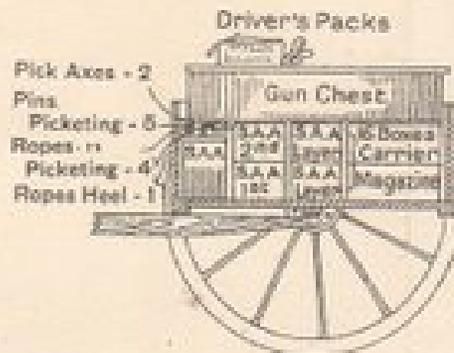


The Holdalls are laid between the Chests on top of the shovels, - 3 side by side on edge and one flat on top of the other three.

The Distance Blocks are placed at the ends of the Chests and are retained in position by the cover.

The Horse Rugs are folded and placed in position over all before the cover is put on.

REAR PORTION

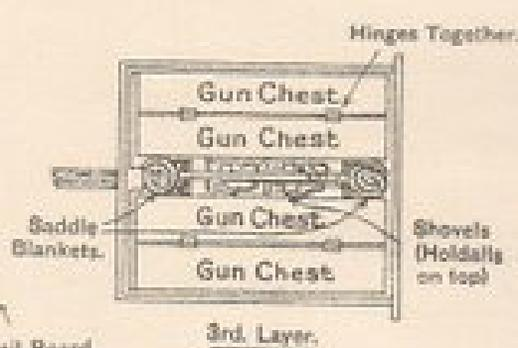
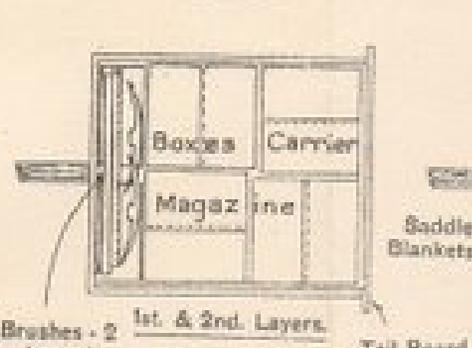
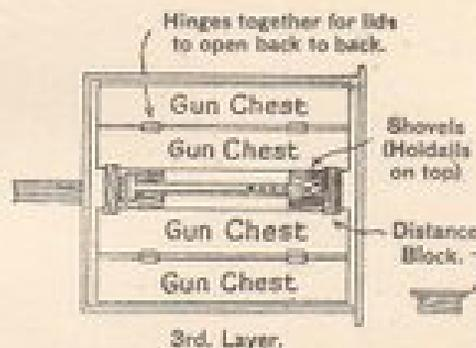
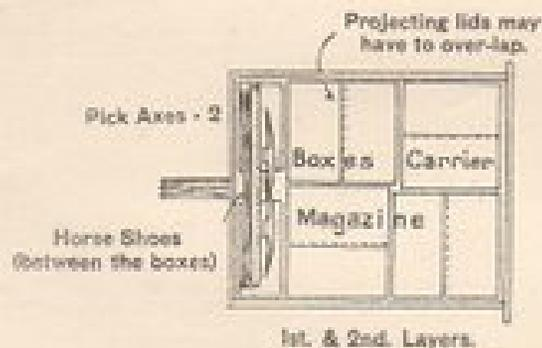


The Holdalls are laid between the Chests three side by side on edge and one flat on top.

The Distance Blocks are not required for rear half limber.

The Driver's packs are placed on front of Rear Portion.

The A.A. GUN AND MOUNTING AND ONE MAGAZINE CARRIER are carried outside the cover.



iv. *Items for use of driver or horses.*

Hay nets	4
Horse rugs	4
Horse shoes in valise, pairs	8
Surcingles and pads	2

The total ammunition carried on the fore portion is 6256 rounds.

In magazines 80 each of 47 = 3760 rounds.

Carton packed in boxes 2 each of 1248 = 2496 rounds = 1564 rounds for each gun.

The rifles of the drivers are carried in clips on the front and side of limber.

*Rear portion.*v. *Lewis gun equipment.*

Lewis machine guns with cover, mounting, sling and carrying handle	4
Machine gunners' gloves, pairs	4

{ in 4 gun chests
1 gun is prepared for A.A. firing and carried outside the cover
1 outside the cover

Spare parts holdalls

Filled magazines	80
Empty magazines	8*
Magazine pouches	80
Braces	40
Magazine carriers	8

{ (Carried in 16 magazine boxes, each with loading handle)

* Four of these magazines, specially marked for A.A. purposes, filled with the proportion of tracer and armour-piercing ammunition as authorized from company reserve, are carried outside the cover in a magazine carrier.

Lewis gun holder for A.A. tripod	1
A.A. mounting	1
A.A. sight	1 set on gun.
Aim corrector	1 in chest marked " S."
vi. <i>Ammunition not in magazines.</i>	
Boxes of carton packed S.A.A.	2
vii. <i>Other company items carried.</i>	
Pickaxes	2
Shovels	2
viii. <i>Items for use of driver and horses.</i>	
Saddle blankets	2
Harness brushes	2
Water buckets (canvas) ...	3
Horse brushes	4
Rubbers, horse	4
Pegs, picketing	5
Ropes, heel	1
Ropes, picketing	4
Packs of drivers	2

The total ammunition carried on the rear portion is 6256 rounds.

In magazines 80 each of 47 = 3760 rounds.

Carton packed in boxes 2 each of 1248 = 2496 rounds = 1564 rounds for each gun.

When on the line of march in peace, the A.A. gun is in the chest with the range indicator and the A.A. sights. The A.A. mounting is under the cover.

3. The *pouch equipment*, with one full *magazine* in each *pouch*, the *magazine carriers* and the empty *magazines* are packed into the *boxes, carrier, magazine*. These *boxes* should be marked with distinguishing marks so that they are easily recognized by the section concerned as a whole and as individuals with reference to their "numbers" in the section.

Each *box* is divided into two compartments and should be filled with the following equipment:—

	Loading handles	Filled magazines	Empty magazines	Pouches	Magazine carriers
No. 1 box	1	4	1	4	1
.. 2 ..	1	4	1	4	1
.. 3 ..	1	6	—	6	—
.. 4 ..	1	6	—	6	—

In filling Nos. 1 and 2 *boxes*, two filled *magazines*, in *pouches*, should be placed in each half of the *box*; the empty *magazine* and the empty *magazine carrier* being placed on top of the *pouches*.

In Nos. 3 and 4 *boxes* a complete set of *pouches* is put in first with 2 *pouches* in each compartment; the remaining set being divided into two and each half set put into these *boxes*, with one *pouch* in each half.

In putting the *pouches* into the *box* care must be taken to see that the buckles are put in one of the corners, otherwise difficulty will be experienced in shutting the lid.

No. 1 box contains the *magazines* and equipment required by the section commander, No. 1 and No. 2.

No. 2 box contains the equipment required by No. 3. Nos. 3 and 4 boxes contain the equipment required by the remaining three numbers of the section.

4. The gun *chests* contain the following:—

The gun, mounting, sling, cover, carrying handle, and gloves. One *chest* in each half-limber contains in addition:—

- 1 spare barrel.
- 1 piston rod with cylinder.
- 1 jack screw with collar assembling and removing barrel.
- 1 filled wallet No. 1.

This chest is marked "Lewis .303-inch M.G., Mk. I, & S."

5. The chests containing the additional items should be packed as follows:—

Standing in front of the chest:—

- i. Place the filled *wallet* No. 1 in the left-hand end of the chest under the *gun chock*, with the tin *spare parts box* to the left. The *chock* must be replaced with the large arch down and the extension to the left.

- ii. Place the *piston rod* inside the *cylinder*, in the fittings on the front bottom of the chest. Turn the T piece.
- iii. Place the spare *barrel*, with *jack screw* and *collar* assembled, in the fitting on the bottom of the rear of the chest. Turn the T piece over the arm of the jack.
- iv. Detach the *butt* from the gun, keeping the *sling* and *field mount* on. Place the *butt* into position in the right front of the chest with the *heel* of the *butt* uppermost and with the *butt cap* pointing to the left.
- v. Place the gun in the chest as far forward as possible, seeing that the *sling* lies as flat as possible.
- vi. Place the *carrying handle* in the recess in rear of the gun.
- vii. Put the *breech cover* on top of the gun, clear of the checks on the lid.
- viii. The *gloves* are placed between the gun and the front of the chest.

The remaining chests should have the items they contain placed in corresponding positions to those in the "spares" chest.

When on the line of march in peace, the A.A. *sights* and A.A. *solder* will be placed in one of the chests. They should be between the *radiator casing* and the rear of the *chest*.

6. The limber should be packed * as shown in Plate 24.

i. *Fore portion.*

1st layer :

- 2 boxes carton packed S.A.A.
- 8 boxes carrier magazine, in pairs, headers and stretchers with handles to the inside and rear respectively. These should be the Nos. 3 and 4 boxes of the sections.
- Valise containing horse shoes—between the boxes, ammunition.

2nd layer :

- 8 boxes carrier magazine, packed as above, the stretchers coinciding with the headers of the 1st layer. These should be the Nos. 1 and 2 boxes of the sections.
- 2 axes, pick—on S.A.A. boxes with heads separate.
- 2 surcingles with pads—with the axes, pick.

3rd layer :

- 4 guns in their chests
- 2 shovels between gun chests.
- 4 holdalls between the chests, 3 on edge, side by side, and 1 on top of the other 3, with distance blocks placed at ends of chests.

Lastly, 4 rugs, horse.

* The boxes of each section should be packed together in the limber, *i.e.* the No. 1 and 2 boxes of each section should be directly above the 3 and 4 boxes of that section.

The chests and boxes should always be packed into the same positions on the limber to facilitate unloading in the dark.

ii. *Rear portion.*

1st layer :

As for fore portion, substituting 2 harness brushes, 4 horse brushes and 4 rubbers, horse, for the horse shoes.

2nd layer :

As for fore portion, substituting 5 pegs, picketing, 4 ropes, picketing, and 1 rope, heel, for surcingles and pads.

3rd layer :

As for fore portion, except that 3 water buckets are underneath the shovels, and the horse blankets replace the distance blocks. Lastly, drivers' packs and A.A. mounting, on the line of march, in peace.

7. *Drill for loading and unloading the limber in war.*—In order to prevent confusion at the limber on the receipt of orders to take the guns out for action, it is essential that each man should know where to go and what to do when these orders have been given. Therefore a simple drill for loading and unloading should be taught to the light automatic sections.

- i. On receipt of the order to take the guns out for action, four sections, two to each half-limber, under their section leaders will advance to selected positions near the limber. Sections will normally be called up in the order in which the gun chests are packed, *i.e.* from right to left on each half-limber.

- ii. On the command "Prepare for Action," given by the C.S.M. or N.C.O. detailed to supervise the operation, the Nos. 1, 2 and 3 of the A.A. section will take the A.A. gun from the limber and mount it in a suitable position as for "Aircraft Action." The No. 3 will then return to the limber. The gun will remain ready for action subject to the orders of the company commander.
- iii. The section leaders will receive instructions from the N.C.O. supervising unloading as to the position at which their sections will unpack their equipment. In the case of the A.A. section this will be the position at which the gun is mounted.
- iv. The Nos. 1 and 2, other than those of the A.A. section, advance to the limber; untie the cords; remove the cover and the horse rugs or packs; the Nos. 2 sling their holdalls over their shoulders. Nos. 1 and 2 lift their gun chests off the limber and move to the section position, take out the guns, and prepare for action. The Nos. 3 and 4 of the A.A. section will advance with the Nos. 1 and 2 of the other sections and remove their empty chest from the limber and place it on the ground beside the limber.
- v. The Nos. 3 will remove the shovels, water buckets, and saddle blankets and place them on the ground beside the limber. They will then take out boxes Nos. 1 and 2 and move

- them to the section position, where they give the No. 1 box to the Nos. 2 (No. 5 in A.A. section), each of whom distributes the four magazines between the section leader, No. 1 and himself (No. 2 in A.A. section).
- vi. The Nos. 4 take the remaining two boxes to the section position and distribute the magazines to their respective numbers.
During this unloading it may be necessary to remove gun chests, &c., of sections waiting to come up; such equipment will be placed on the ground near the wheel of the limber.
 - vii. Remaining sections will then be called up. They will collect their guns and equipment as above.
 - viii. The Nos. 6 of the last two sections to unload each half-limber will, when reloading commences, *remove the reserve boxes of S.A.A. and ensure that these are replaced at the rear of the half-limber so as to be accessible when required.*
 - ix. When all guns, equipment, &c., are laid out, the empty chests, boxes, and other items not immediately required will be reloaded in the reverse order, starting with the last four sections to unload, any chests, &c., which cannot be replaced by them being left on the ground near the limber for the remaining sections to load up. When orders are given to prepare the A.A. gun for ground action, the No. 2 will receive the A.A. sights and holder

from the No. 1, place them in the gun chest and return with the carrying handle. He will also be responsible for placing the A.A. mounting on the limber between the gun chests.

APPENDIX III

LEWIS GUN PACKSADDLERY AND EQUIPMENT. DRILL FOR LOADING AND UNLOADING

1. *Ground guns*

1. When light automatics are carried on pack, two mules will be allotted to each platoon to carry the guns, spare parts and 20 magazines.

One mule will be allotted to each company for the purpose of carrying 16 magazines (8 filled for A.A. use and 8 empty), the A.A. mounting and the spare parts issued on the scale of 1 for 4 guns.

2. *Composition of loads.*

i. *Gun Animal.*

(a) *Near Side.*—Top (No. 1) Box—4 magazines in a half set of pouch equipment (*i.e.* 2 magazines in each pouch) in each compartment. Total, 8 magazines, 1 set of pouch equipment and 1 loading handle.

Bottom (No. 2) Box—3 magazines in a half set of equipment and 1 picketing rope in the forward compartment. 1 magazine in a pouch, 2 empty carriers, heel rope, horse brush and horse rubber in the rear compartment. Total, 4 magazines, $\frac{1}{2}$ of a set of pouch equipment and 1 loading handle.

(b) *Off Side*.—Gun in cover * with mounting and sling (No. 3) Box, 4 magazines in a half set of pouch equipment in each compartment.

Total, 8 magazines, 1 set of pouch equipment and 1 loading handle.

The horse shoes are carried on the front arch of the pack. The feed-bag is attached to the rear arch and can be thrown either side to balance the load. The picketing pegs will be secured by special strap fittings to the rear of each rack.

ii. *A.A. Ammunition and Spares Animal.*

(To accompany the gun detailed for A.A. duties.)

(a) *Near Side*.—8 magazines (4 filled for A.A. use and 4 empty) in a box carrier magazine, 2 filled and 2 empty in each compartment. A picketing rope is also carried in one compartment. 1 case, spare parts, Lewis, containing 1 spare barrel, 1 cylinder, gas, 1 rod, piston and 1 filled wallet No. 1.

(b) *Top Load*.—1 carrier, A.A. mounting, Lewis, with A.A. mounting.

* The gun detailed for A.A. duty will be carried with the A.A. sights and holder attached.

The carrying handle will be detached from the gun and secured to the cover by passing the cover strap through the handle.

(c) *Off Side*.—8 magazines (4 filled for A.A. use and 4 empty) in a box carrier magazine, 2 filled and 2 empty in each compartment. 1 case, spare parts, Lewis, containing 1 spare barrel, 1 cylinder, gas, 1 rod, piston and 1 filled wallet No. 1.

iii. *Distribution of M.G. Stores on the Gun Animal.*

No. 1 Box contains magazines for Nos. 3 and 4, and equipment for No. 3.

No. 2 Box contains magazines and equipment for section commander and Nos. 1 and 2.

No. 3 Box contains magazines for Nos. 5 and 6, and equipment for No. 5.

Nos. 4 and 6 of each section will carry the empty pouch equipment on the line of march.

3. The packsaddlery is assembled in the correct manner. The loads are attached to the packsaddle as follows:—

i. *Gun Animal.*

(a) *Near Side*.—The rack is suspended by its "eyes" to the hooks of the packsaddle. Two boxes, carrier, magazine, are placed in the rack with handles to the front, and secured by the quick-release "V"-shaped strap which is attached to the rack. The nose-bag should be suspended from the rear arch of packsaddle and can be thrown either side to balance the load.

(b) *Top*.—The case, horse shoe, should be buckled to the front of the rear arch of packsaddle. The load should be secured by the surcingle passing over the side loads and under the top load. The surcingle should be passed through the handle of the holdall.

(c) *Off Side*.—The rack is suspended in a similar manner to that on the near side. One box, carrier, magazine, is then placed in the rack and secured as on near side.

The straps, carrying, gun (fore and hind), are then placed on the hooks of packsaddle and the slots in the blocks functioning over the sides of the carrier.

The gun, in cover, is then placed in the carrying straps, hooked on and secured by the cross straps.

The holdall is carried between the gun and the box, carrier, magazine, and is hung by the sling from the hooks. In all cases the racks are steadied by the leather girths attached to them, being secured under the belly of the animal.

ii. *A.A. Ammunition and Spares Animal.*

(a) *Near Side*.—The rack is suspended by its "eyes" to the hooks of the packsaddle. One box, carrier, magazine, is placed on the rack. The case, spare parts, Lewis, is suspended by its "eyes" to the hooks

of the packsaddle and secured by the "V"-shaped strap.

(b) *Top*.—The A.A. mounting is strapped firmly to the carrier, A.A. mounting, Lewis, by the straps on the carrier. The case, horse-shoe, should be buckled on to the "D" in the centre of the carrier, A.A. mounting, Lewis. The nose-bag should be suspended from the rear arch and can be thrown to either side to balance the load.

The carrier, A.A. mounting, Lewis, is placed between the arches of the packsaddle and secured by passing the straps at the ends of the carrier through the "Ds" on the arches.*

(c) *Off Side*.—The rack is suspended by its "eyes" to the hooks of the packsaddle. One box, carrier, magazine, is placed on the rack. The case, spare parts, Lewis, is suspended by its "eyes" to the hooks of the packsaddle and secured by the "V"-shaped strap.

iv. The load should be secured by the surcingle, Lewis.

* 1. The straps which fasten the A.A. mounting to the carrier should be passed round the A.A. mounting *once* only.

2. With the Mk. I^a A.A. mounting the extension post should be removed and attached to the leg of the mounting by the clips provided.

4. *Drill for unloading company guns (for action).*

i. Gun animals if not actually with the platoons will join their platoons under instructions from the company commander.

ii. Nos. 1 and 2 of each section will unfasten the *surcingle*, remove the *gun* and *holdall*, take them to section positions and prepare guns for action.

At the same time Nos. 6 will remove *Box No. 1*, take them to section positions, hand 4 *magazines* to No. 4, and the *equipment* containing 4 *magazines* to No. 3.

iii. Nos. 4 will remove *Box No. 2* and distribute contents to the section commander and Nos. 1 and 2. Care should be taken that *picketing gear* is not lost.

At the same time Nos. 5 will remove *Box No. 3*, hand 4 *magazines* to the Nos. 6, and put on *equipment* containing 4 *magazines*.

iv. To load the pack, the above movements should be reversed. When the empty boxes are reloaded, No. 1 will remain with the gun. No. 2 will put *gun cover* on top of No. 3 *Box* under the "*V*" *strap*. He will refasten *gun straps* and *surcingle*.

v. When unloading during halts, the above numbers will remove the same items of equipment and stack them on the left of the road, but will not distribute any equipment without further orders.

5. Pending the issue of the rack ammunition carriers, light automatics will be carried on the pack in the old pattern saddlery.

i. The following differences in method of packing should be noted :—

(a) 18 magazines on each gun animal and the 32 magazines on the company ammunition animal will be packed in carriers without any pouch equipment or carriers, magazine.

(b) Spare parts will be hung over the valise L.G. containing the picketing gear.

(c) 2 valises in each company will contain the following in addition to picketing gear :—

1 spare barrel (secured by leather thongs).

1 cylinder (in accessories case).

1 piston rod complete (in accessories case).

1 jack screw with collar (assembled to barrel).

1 filled wallet No. 1.

(d) All the numbers of light-automatic teams will carry empty pouch equipment on the line of march.

ii. Packsaddlery will be assembled in the correct manner. Loads are attached to the pack-saddle as follows :—

Gun Animal.

- (a) *Off Side.*—One ammunition carrier containing 9 filled magazines is suspended from the hooks on the packsaddle by means of straps suspending ammunition carrier front and rear. The gun is then suspended from the hooks in the hanger gun sling. The nose-bag should be suspended from the rear arch of the packsaddle and can be thrown to either side to balance the load.
- (b) *Top.*—The shoe case should be buckled to the front of the rear arch.
- (c) *Near Side.*—The valise is suspended by its "eyes" from the hooks on the packsaddle. One ammunition carrier containing 9 filled magazines is suspended by the eyes and "Ds" from the bottom of the valise. The holdall will be hung from the hooks of the packsaddle, handle down, and rested on the outside of the valise.
- (d) The empty ammunition carriers (buckets) will be placed on the valise and securing strap passed through the handles.
- (e) The load should be secured by the straps passing over the load and buckling on to the belly-band.

Ammunition Animal.

- (f) An ammunition carrier containing 8 filled magazines will be suspended by the links on either side from the hooks of the packsaddle. A second ammunition carrier containing 4 filled magazines for A.A. use and 4 empty will be attached to the first carrier by means of the "eyes" and "D."
- (g) *Top.*—The A.A. mounting is strapped firmly to the carrier, A.A. mounting, Lewis, by the straps on the carrier. The case, horse-shoe, should be buckled on to the "D" in the centre of the carrier, A.A. mounting, Lewis. The nose-bag should be suspended from the rear arch and can be thrown to either side to balance the load.
- The carrier, A.A. mounting, Lewis, is placed between the arches of the packsaddle and secured by passing the straps at the ends of the carrier through the "Ds" on the arches.
- (h) The load is secured in a similar manner to that of the gun animal.
- iii. When this packsaddlery is in use the following will be the method of unloading :—
- (a) Nos. 1 and 2 of each section will remove gun and holdall, taking them to the section positions and prepare for action.

LOAD TABLES.—continued.

(b) A.A. Ammunition and Spare Animals

Near Side	No.	Weight lb.	Top Load	No.	Weight lb.	Off Side	No.	Weight lb.
Boxes, carrier, magazine ...	1	91	A.A.L.A. Mount- ing, Mk. 1* ...	1	161	Boxes, carrier, magazine ...	1	91
Magazines, filled	4	174	Bags, nose, with feed, hanging from rear arch of packsaddle.			Magazines, filled	4	174
" empty	4	74	Can be thrown to either side			" empty	4	74
Cases, spare parts, Lewis ...	1	14	to balance loads			Cases, spare parts, Lewis	1	14
Spare, 1 to 4 guns sets	1	81	Shoes, horse or mule, with nails, in case pairs	1	21	Spare, 1 to 4 guns sets	1	81
Picketing gear and horse equipment	1	5	Carrier, A.A. mounting, Lewis ...	1	2	Picketing pegs Racks ...	2	10
Racks ...	1	15					1	15
Total ...		64	Total ...		294	Total ...		644

2. H.Q. anti-aircraft guns

1. When light automatics are carried on pack, two mules will be allotted to the H.Q. anti-aircraft light-automatic guns of an infantry battalion.

2. Composition of load.

- i. *Near side*.—5 filled magazines in each compartment of box, carrier, magazine. The case, spare parts, Lewis, containing spare barrel, gas cylinder, rod, piston, and filled wallet No. 1.*
- ii. *Top*.—Carrier, A.A. mounting, Lewis, with A.A. mounting.
- iii. *Off side*.—1 gun with sling, mounting and holder and A.A. sights, attached.
1 holdall with spare parts.

3. Packsaddlery is to be assembled in the correct manner. Articles forming the loads are attached to the packsaddle as follows:—

- i. *Near side*.—The rack is suspended by its "eyes" to the hooks of the packsaddle. One box, carrier, magazine, is then placed in the rack with handle to the front. The case, spare parts, Lewis, is suspended by its "eyes" to the hooks of the packsaddle and secured by the "V"-shaped strap. The magazine carriers are placed on the box under the quick-release strap.
- ii. *Top*.—The A.A. mounting is strapped firmly to the carrier, A.A. mounting, Lewis, by the straps

* In an infantry battalion one mule only will carry the spares on the near side.

on the carrier. The case, horse-shoe, should be buckled on to the "D" in the centre of the carrier, A.A. mounting, Lewis. The nose-bag should be suspended from the rear arch and can be thrown to either side to balance the load.

The carrier, A.A. mounting, Lewis, is placed between the arches of the packsaddle and secured by passing the straps at the end of the carrier through the "Ds" on the arches.

iii. *Off side.*—The rack is suspended by its "eyes" to the hooks of the packsaddle.

The straps, carrying, gun (fore and hind), are then placed on the hooks of the packsaddle, the slots in the blocks functioning over the sides of the carrier. The gun is then placed in the carrying straps, hooked on and secured by the cross straps. The holdall is carried over the gun and is hung from the packsaddle hooks by the sling. The load should be secured by the surcingle, Lewis, which should be passed through the handle of the holdall.

4. *Drill for unloading.*

i. *For A.A. action.*

- (a) No. 3 removes the *A.A. Mounting* and erects it for A.A. action.
- (b) Nos. 1 and 2 unfasten *surcingle*, remove *gun* and *holdall* and prepare for A.A. action.
- (c) No. 3 returns to the mule and removes *box, carrier, magazine*, containing the *ammunition*.

ii. *At halts on the line of march.*—Nos. 1 and 2 unfasten *surcingle* and remove *gun* and *spare parts*; at the same time No. 3 will remove the *box, carrier, magazine*, and *case, spare parts, Lewis*.

5. Pending the issue of the rack ammunition carriers, light automatics will be carried on the pack in the old pattern saddlery. It should be noted that in this case only 9 magazines for each gun can be carried on the mule.

i. Packsaddlery is assembled in the correct manner. Articles forming the loads are attached to the packsaddle as follows:—

(a) *Near side.*—The valise is suspended by its "eyes" from the hooks on the packsaddle. One ammunition carrier containing 9 filled magazines is suspended by the eyes and "Ds" from the bottom of the valise. One empty carrier (bucket) is carried on top of the ammunition carrier with the securing strap through the handle.

(b) *Top.*—The A.A. mounting is strapped firmly to the carrier, A.A. mounting, Lewis, by the straps on the carrier. The case, horse-shoe, should be buckled on to the "D" in the centre of the carrier, A.A. mounting, Lewis. The nose-bag should be suspended from the rear arch and can be thrown to either side to balance the load.

The carrier, A.A. mounting, Lewis, is placed between the arches of the packsaddle and secured by passing the straps at the end of the carrier through the "Ds" on the arches.

c) *Off side.*—The gun is suspended from the hooks in the hanger gun sling. The holdall is hung on the hooks of the packsaddle by the sling, handle to the top, over the gun, and securing strap is passed through the handle and under the holdall.

The load should be secured by the straps passing over the load and buckling on to the belly-band.

ii. Drill for unloading.

For A.A. action.

(a) No. 3 will remove *A.A. mounting* and erect it for A.A. action, return to the mule, unfasten *securing strap*, take off *bucket carrier*, put in it 4 *magazines* from the *ammunition carrier* and take the *ammunition* to the gun.

(b) Nos. 1 and 2 will unfasten *securing strap*, remove *gun* and *holdall* and prepare for A.A. action.

At halt on the line of march.—Nos. 1 and 2 will unfasten *securing strap* and remove *gun* and *holdall*. At the same time No. 3 will also unfasten *securing strap* and remove *ammunition carrier* by opening the quick-release buckles by which it is attached to the *valise*.

6. LOAD TABLES
H.Q. A.A. Light Automatics

Near Side	No.	Weight lb.	Top Load	No.	Weight lb.	Off Side	No.	Weight lb.
Gun, etc. ...	1	324	Mountings, A.A. ...	1	16½	Magazines ...	10	43½
Straps, carrying, gun—	1		Bags, nose ...	1	8	Racks, box, carrier ...	1	18
front ...	1	84	Shoes, horse or mule, with nails in case	1	24	Boxes, carrier, magazine ...	1	9½
rear ...	1		pairs			Cases, spare parts, Lewis	1	14
Backs, box, car- rier with pack- eting, peg at- tached ...	1	16	Carriers, A.A. mounting,	1	2	Spare on scale of one per 4 guns ...	1	84
Holdall ...	1	94	Lewis ...			Total		76
Total ...		624	Total ...		294	Total		

3. Scales of Packsaddlery
(a) New pattern packsaddlery

Description	Number for each		
	Gun set Ground guns	Ammunition and spares set	Gun sets A.A. guns
<i>Section D.1.</i>			
Packsaddlery, G.S.—			
Bits, bridoon. ...	1	1	1
Breechings Mk. V. ...	1	1	1
Cases, horse shoe ...	1	1	1
Chains, collar. G.S. Mk. IV. ...	1	1	1
Collars, breast, Mk. V. ...	1	1	1
" head, Mk. IV. ...	1	1	1
Cruppers, Mk. V. ...	1	1	1
Girths, Mk. V. ...	2	2	2
Pannels, Mk. V. pair	1	1	1
Reins, bridoon. ...	1	1	1
Straps, girth, Mk. II. ...	4	4	1
Trees, adjustable ...	1	1	1
Packsaddlery, M.G.—			
inch —			
Cases, spare part, Lewis	1	2	1
Carriers, A.A. mounting, Lewis ...	—	1	1
Covers, gun, Lewis ...	1	—	1
Racks, box carrier, mag. Lewis near	1	1	1
" off	1	1	1
Straps, carrying, gun, Lewis fore	1	—	1
" hind	1	—	1
Surcingle, Lewis ...	1	1	1

(b) Old pattern packsaddlery

Description	Number of each	
	Gun set	Ammunition set
<i>Section D.1.</i>		
Packsaddlery, G.S.—		
Bits, bridoon ...	1	1
Breechings, Mk. V. ...	1	1
Cases, horse shoe ...	1	1
Chains, collar, G.S. Mk. IV. ...	1	1
Collars, breast, Mk. V. ...	1	1
" head, Mk. IV. ...	1	1
Cruppers, Mk. V. ...	1	1
Girths, Mk. V. ...	2	2
Pannels, Mk. V. ... pair	1	1
Reins, bridoon ...	1	1
Straps, girth, Mk. II. ...	4	4
Trees, adjustable ...	1	1
Packsaddlery, M.G.—		
Bands, belly ...	1	1
" straps, long ...	1	2
" short ...	1	—
" supporting ...	2	2
Cases, accessories* ...	1	—
Hangers, gun sling ...	1	—
Carriers, ammunition ...	2	4
Straps, suspending amm. carriers, Lewis, M.G. front	1	—
" rear	1	—
Straps, A.A. mounting ...	—	1
Valises, L.G. ...	1	—

* In infantry battalions, one case, accessories, to four gun sets.

APPENDIX IV

No. 54 H. E. GRENADE

(Plates 25 and 26)

LESSON 1.—MECHANISM

1. Preliminaries.

i. *Stores required.*—One cut grenade. Table and forms or waterproof sheet.

ii. *Preliminaries.*—Squad seated round a table or in any convenient place. Instructor explains *the first safety precaution*: When about to handle a grenade it is essential that the first safety precaution should at once be carried out. This consists in removing the *base plug* and ensuring that the grenade is not primed. Instructor strips cut grenade.

2. Sequence of instruction.

i. Instructor states that he is going to teach the mechanism of the No. 54 High Explosive Grenade. It is a percussion grenade which can be fired from the rifle or thrown by hand. Range when fired—100 yards to 325 yards.

ii. Describes the *body* of the grenade:—

The body of the grenade is made of cast iron and is fitted with two *flanges* to keep it

PLATE 25

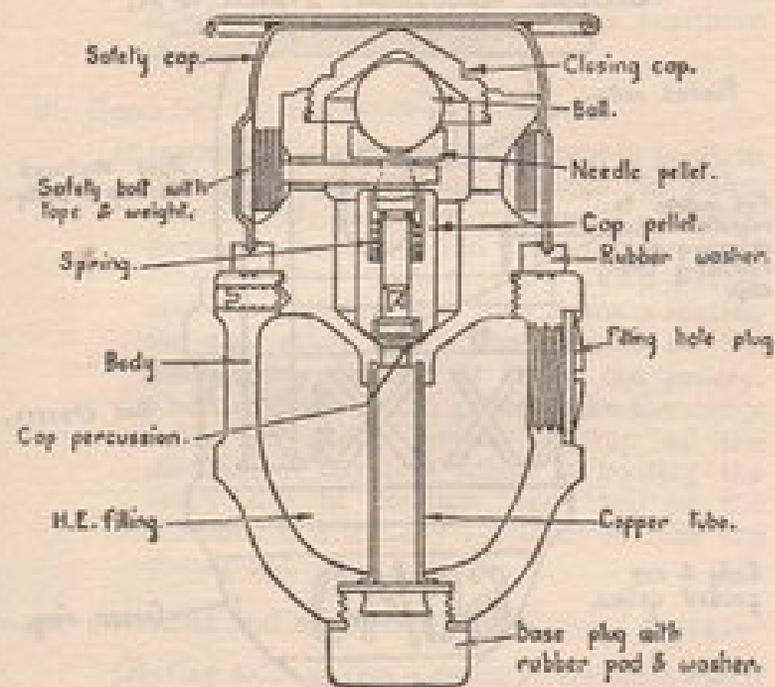
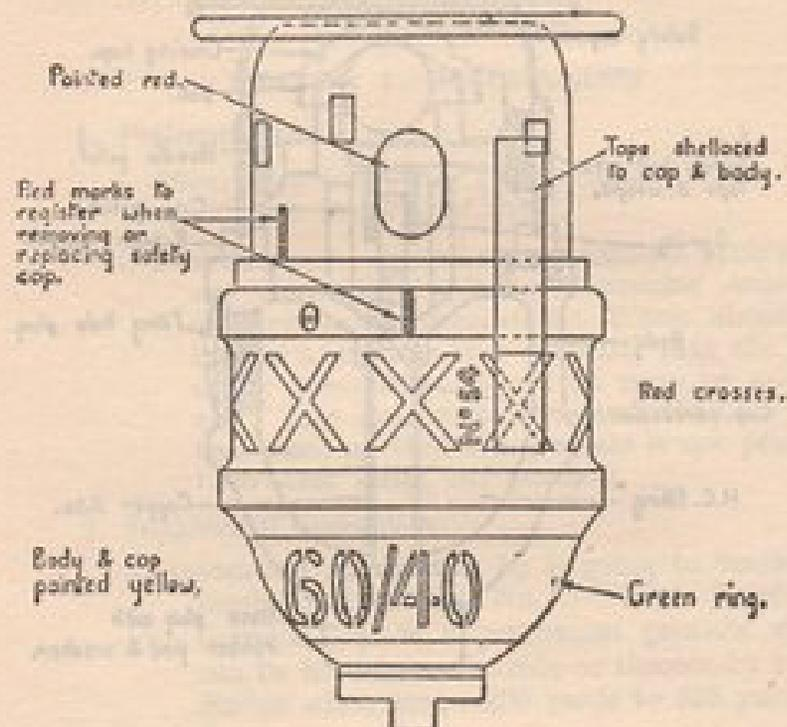
GRENADE, PERCUSSION, 2-INCH, N^o 54.

PLATE 26

GRENADE, PERCUSSION, 2-INCH. N° 54.



steady when in the *discharger*. The base is screwed internally to receive the *base plug*. Into the open end is screwed the *mechanism chamber*; on the side there is a *filling-screw* which closes the grenade after it has been filled with high explosive. The explosive in this grenade is *baratol*.

iii. Describes the *mechanism chamber* :—

It is screwed into the *body* and kept in position by a small *stud* passing through the *flange* on the *body* into the *mechanism chamber*. Between the *body* and the *chamber* is a *rubber washer*. This prevents damp getting into the explosive and also forms a seating for the *safety cap*. The outside of the *mechanism chamber* is called the *gallery*. The two holes in the *gallery* take the *safety bolt*. The three *flanges* on top of the *mechanism chamber* assist in holding the *safety cap* in position. The top of the *chamber* is internally threaded to take the *closing cap*.

iv. Describes and assembles the following parts :—

- (a) *Cap pellet*.—Has a recess in the base which takes the *cap*. It has a small *channel* to take the *striker*. It has a larger *recess* on top to take the *creep spring*. When the pellet is in the grenade the *cap* is on top of the *detonator sleeve*.

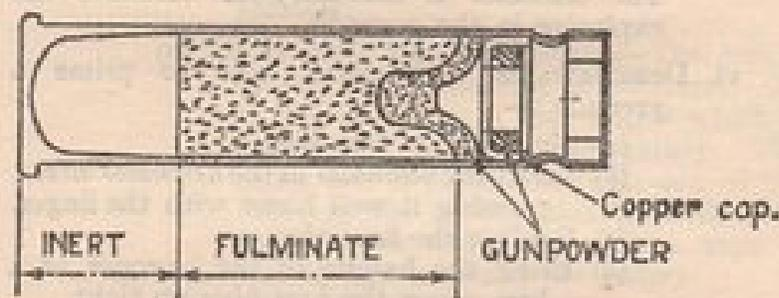
- (b) *The needle pellet.*—On top there is a cone-shaped *tray*. The shank below the tray has a hole in it through which the *safety bolt* passes. Attached to the shank is the *creep spring*. At the base of the *striker* there are two prongs. The *needle pellet* fits into the *cap pellet*.
- (c) A small steel ball fits on top of the tray of the *needle pellet*.
- (d) The *closing cap*, which is cone shaped inside, screws into the *mechanism chamber*.
- (e) *Safety bolt, tape and weight.*—The *bolt* is hinged on to one end of the *tape*. On the other end is a *lead weight* which is curved to fit into the *gallery*. The *safety bolt* is passed through one of the holes in the *gallery* and then through the hole in the *striker*. The *tape* is wound tightly round the *gallery*.
- (f) The *safety cap* is put on so that the *projections* inside it pass between the *projections* of the *mechanism chamber*. Turn the *cap* clockwise ensuring that the *projections* are *under* those of the *mechanism chamber*.
- (g) *The base plug.*—A small rubber cushion on top of it forms a seating for the *detonator*. Round the threaded portion there is a *rubber washer*. This excludes

damp and prevents a flash from the *ballistite* passing direct to the *detonator* and causing a premature. On the bottom is a *flange*, which fits into a bayonet handle. The *base plug* screws into the grenade.

- v. Shows squad a *detonator* (Plate 27) and explains that it is filled with a very sensitive explosive mixture. *Detonators* must be handled with great care. A *rim* at one end prevents it being put into the grenade the wrong way. The *detonator* is necessary to detonate the explosive in the grenade.
- vi. Demonstrates with detail how to prime a grenade :—
- (a) Unscrew the *base plug*.
 - (b) Insert the *detonator* in the *detonator sleeve*, pressing it well home with the finger.
 - (c) Replace the *base plug*.
 - (d) Using the handle of the bayonet as a key, screw the *base plug* up tight.
- vii. Explains the action of the mechanism by employing question and answer method. The *cap* having been removed, the *tape* is prevented from unwinding by the forefinger of the thrower or the wall of the discharger. As soon as it is free, the *tape* unwinds and falls off, taking with it the *safety bolt*. The grenade is then said to be "armed." Only the *creep spring* now prevents the *striker* from firing the

PLATE 27

DETONATOR FOR GRENADE N° 54.



cap. On the grenade striking anything, the force of impact causes the *spring* to be overcome and the *striker* to fire the *cap*, resulting in the explosion of the grenade.

viii. *Action after a gas attack.*

(a) *Unprimed* grenades should be cleaned and oiled, care being taken not to remove the safety caps nor displace the shellaced tapes.

(b) *Primed* grenades should be unprimed, thoroughly examined, cleaned, reprimed, and then exterior oiled.

ix. *Describes markings :—*

(a) *Live.*—The live No. 54 is painted yellow. A string of red crosses is painted round the body indicating that the grenade is filled and suitable for use in hot climates, and a half-inch green ring painted near the base denoting "baratol" filling. A small strip of tape across the grenade is proof that a grenade has not been tampered with.

(b) *Dummy.*—The dummy No. 54 is galvanized to give a white appearance.

LESSON 2.—POINTS BEFORE FIRING AND THROWING NO. 54 GRENADE

3. *Preliminaries.*

i. *Stores required.*—1 dummy grenade and 1 dummy detonator for each man.

- ii. Squad seated round table or in any convenient place. Issue dummy grenades. Detonators will not be issued until required.

4. *Sequence of instruction.*

- i. Instructor states object of lesson, *i.e.* to teach the method of inspecting the No. 54 Grenade and its detonator before use, thereby reducing the possibility of blinds or prematures.

- ii. Squad imitates instructor, who gives reasons:—

<i>Precaution</i>	<i>Reason</i>
(a) Remove <i>base plug</i> .	To ensure grenade is not primed.
(b) Examine <i>washer</i> and <i>cushion</i> on <i>base plug</i> .	The <i>washer</i> prevents flash from ballistite entering <i>sleeve</i> and causing premature. The <i>cushion</i> ensures <i>detonator</i> is fully home and stationary. It absorbs any "set-back" of <i>detonator</i> .
(c) Examine <i>detonator sleeve</i> to ensure it is free from dirt, rough edges, dents or cracks, and see that the <i>cap</i> has not been fired.	To ensure free and safe entry of <i>detonator</i> . Rough edges might cause a premature. Uneven or bent <i>sleeve</i> might prevent easy insertion of <i>detonator</i> . If <i>cap</i> has been fired, the grenade is unsuitable for use (<i>see</i> Note under (f)).

<i>Precaution</i>	<i>Reason</i>
(d) Examine <i>body</i> for cracks.	Damp may have got through cracks and might thus cause a blind.
(e) Examine <i>filling screw</i> to see it is properly home and sealed.	Damp might have entered grenade and thus cause a blind.
(f) Remove <i>shellaced taps</i> . [*] Remove <i>cap</i> , partially unwind <i>taps</i> and see that the <i>taps</i> and <i>weight</i> are in good order and not held up in any way. Replace the <i>cap</i> , ensuring that <i>rubber washer</i> is in position.	To prevent blinds due to <i>taps</i> failing to unwind. <i>Rubber washer</i> provides a correct and firm seating for <i>cap</i> .
(g) Scrape off any excess of shellac or paint from <i>guide rings</i> .	May prevent grenade from entering the <i>discharger</i> .
(h) The <i>safety bolt</i> will on no account be removed when examining.	To prevent the <i>cap</i> being accidentally fired before priming, thereby rendering grenade useless.
iii. Replace <i>base plugs</i> and return grenades to box.	
iv. Issue <i>detonators</i> and explain that throughout examination they will be held carefully	

* If *shellaced taps* is found to be broken or detached, examine *centre sleeve* to see if *cap* is fired. If fired, destroy. In war, whether fired or not, do not use.

between the forefinger and thumb, and grasped by the rim. Care must be taken that the *detonators* are not struck, crushed, or bent, nor subjected to heat or friction. No attempt will be made to interfere with the substance contained in them.

*Precaution**Reason*

- | | |
|--|---|
| (a) That it is not bent or dented. | Bent or dented detonators are unlikely to enter the <i>sleeve</i> freely. |
| (b) That the mouth is sealed with paper. | Damp might enter and cause a <i>blind</i> . |

v. Detonators returned to box.

**SPECIAL INSTRUCTIONS FOR FIRING LIVE
NO. 54 GRENADES**

5. See Sec. 28, General Instructions.

6. If, through faulty ballistite or faulty handling, a grenade is dropped in the bay after the *safety cap* has been removed, the N.C.O. in charge will recover the grenade, rewind the *tape*, replace the *cap*, and continue the practice with the same grenade. Whilst recovering the grenade the N.C.O. will secure his steel helmet or anything likely to fall and disturb the grenade. The man under instruction will remain perfectly still until the grenade has been recovered. Should the N.C.O. in charge have any doubt about the *safety bolt* being in its proper position, he will clear the bay and inform the officer in charge. If the officer in charge is also in doubt,

he will deal with it as a blind, and destroy it where it lies.

**SPECIAL INSTRUCTIONS FOR THROWING LIVE
NO. 54 GRENADES**

7. See Sec. 25, General Instructions.

8. See above as for firing.

APPENDIX V

2-INCH DISCHARGER

(Plate 28)

1. Description.

i. *Discharger*.—It is a steel barrel large enough to contain a grenade. The outside is roughened to give a grip for the hand when fixing. The lower end is cone-shaped and of smaller bore. It is threaded externally to enter the *bridge*. Near the lower end is a slot which forms a *gas port*. This is closed by means of a *sliding shutter* which can be clamped in certain positions by a *clamping nut*. On the inside of the *barrel* there is a *shelf* which forms a seating for the grenade when in the discharger.

ii. *Bridge*.—This consists of a *cross-piece* and two *screw bolts*. The threaded aperture in the *cross-piece* fits externally on the mouth of the *barrel*, with the gap towards the *bayonet boss*. The ends of the two *bolts* engage in the recesses of the *nosecap* of the rifle. The *nuts* on the *bolts* fit the *slot* in the *handle* of the bayonet.

LESSON

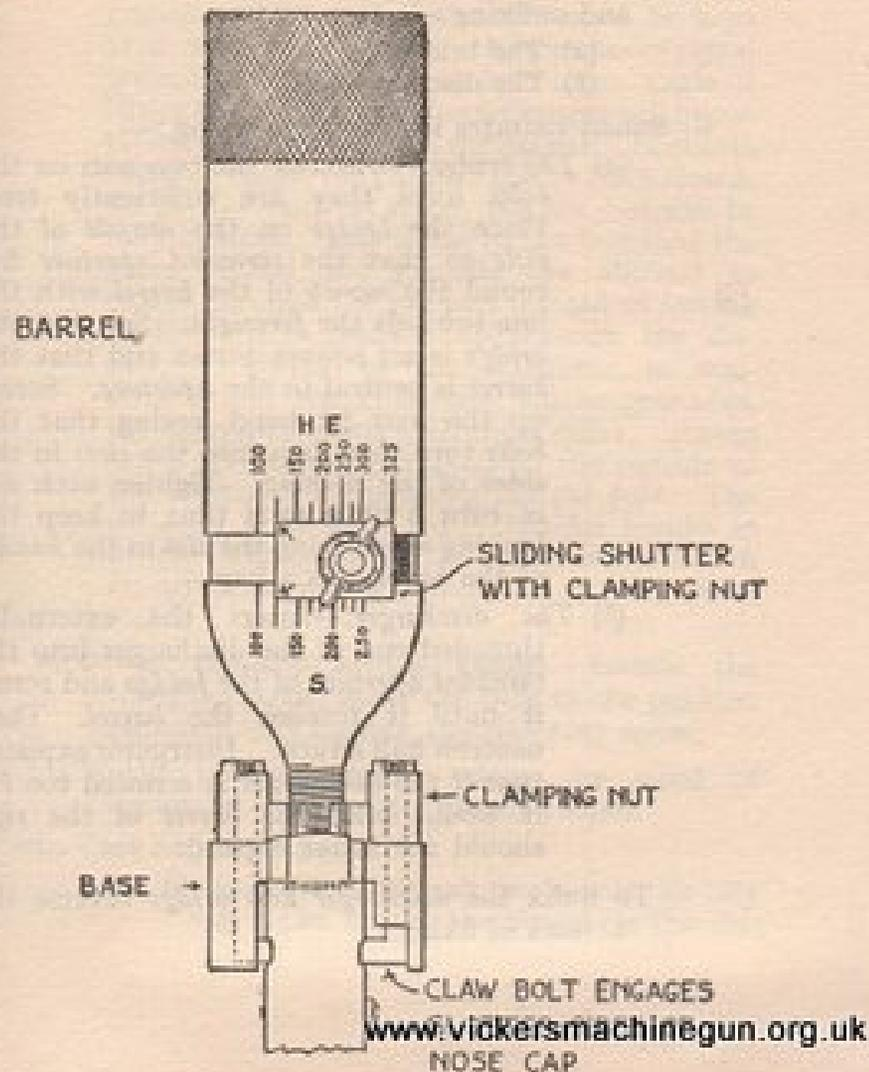
2. Preliminaries.

i. *Stores required*.—1 discharger for each man, 1 dummy blank ballistite.

ii. Inspect arms and dummies. Issue discharger.

PLATE 28

2-INCH DISCHARGER, FOR ATTACHMENT TO RIFLES, No. 1



3. *Sequence of instruction.*

i. Instructor gives *complete demonstration* of fixing and unfixing :—

- (a) The bridge.
- (b) The discharger.

ii. Squad imitates instructor in fixing :—

(a) *The bridge.*—Unscrew the two *nuts* on the *bolts* until they are sufficiently free. Place the *bridge* on the *muzzle* of the *rifle* so that the *threaded aperture* fits round the *mouth* of the *barrel* with the line towards the *foresight*. See that the *bridge* is set square across and that the *barrel* is central in the *aperture*. Screw up the *nuts* by hand, seeing that the *bolts* turn their *lugs* into the *slots* in the sides of the *nosecap*. Tighten each *nut* in turn a little at a time to keep the bearing even, using the *slot* in the *handle* of the *bayonet* as a key.

(b) *The discharger.*—Insert the externally threaded end of the discharger into the *threaded aperture* of the *bridge* and screw it until it reaches the *barrel*. Then unscrew half a turn. Instructor explains that if the discharger is screwed too far it would bend the *barrel* of the *rifle* should the latter expand.

To unfix the *discharger* and *bridge* reverse the actions of fixing.

iii. Squad practises. Instructor checks.

iv. *Range setting.*—When firing H.E. or Smoke grenades the *barrel* of the *rifle* must be kept at an angle of 45 degrees. In the case of signal grenades, the *rifle* will be held at an angle of 70 degrees. Longer or shorter ranges will be obtained by adjustments of the *gas port*. To obtain extreme range, the *gas port* will be fully closed. To get the shortest range, the *gas port* will be fully opened. This is due to the fact that the gases behind the grenade are allowed to escape through the *gas port* instead of having to follow the grenade up through the *discharger*. Owing to the difference in construction of the H.E. and Smoke grenades, the ranges obtained with them differ. Range scales for both are marked on the outside of the *discharger barrel* along the *gas port*. The scale for H.E. is in red; that for Smoke in white. The corner of the *shutter* marked with an arrow acts as a pointer for reading these scales.

v. Squad imitates setting ranges. Loosen the *clamping screw*, move the *slide* to the position required, and tighten the *clamping screw*.

vi. Squad practises range setting by word of command. Instructor checks ranges.

vii. Care and cleaning :—

(a) *Daily.*—Wipe over all parts with an oily rag. The inside, the *thread* on the *dis-*

charger, and the *thread* on the *bridge locking base screw* will be left slightly oily.

- (b) *After firing*.—Remove the *discharger* from the *bridge*, wipe the inside with a dry rag to remove superficial fouling. Thoroughly oil all surfaces and threads, and rub with an oily rag until clean. Wipe dry and then re-oil, paying close attention to the *threads* and *shutter*. The best way to clean the *bridge* is to soak it in oil, then dry clean and re-oil.
- (c) After gas attack, the *discharger* should be cleaned and oiled.

viii. Safety precautions.

- (a) The ballistite grenade cartridge only will be used with the *discharger*. It is distinguished from the .303-inch blank cartridge by being blackened for half its length from the mouth, and the mouth of the case is not crimped. The use of ball cartridge ammunition for firing a grenade is forbidden.
- (b) Ball cartridge ammunition may be fired with the *discharger* on the rifle, but only in an emergency at very close range.
- (c) After firing two or three grenades, the *discharger* will be examined and re-adjusted on the *rifle barrel* if necessary.

APPENDIX VI

2-INCH SMOKE GRENADE

(Plate 29)

1. Description.

The grenade consists of a thin drawn steel cylindrical *body* closed at one end. The *body* is filled with smoke composition, primed at the open end with suitable priming composition, the whole being consolidated under a considerable pressure.

The priming is covered with a *millboard washer* and perforated *millboard discs* pressed in. *Quickmatch* is inserted in the perforations and the grenade is closed by turning over the end of the *body* on to a *steel base plate*. The *base plate* has two perforations sealed by thin *tinned-plate discs* soldered on, positioned to line with the perforations in the *millboard discs*.

During transit the *base* of the grenade is protected by means of a *tinned-plate cap* sprung on. A *steel ring* is secured to the *cap* to facilitate its ready removal before loading into the *discharger*.

2. Preparation of grenade for firing.

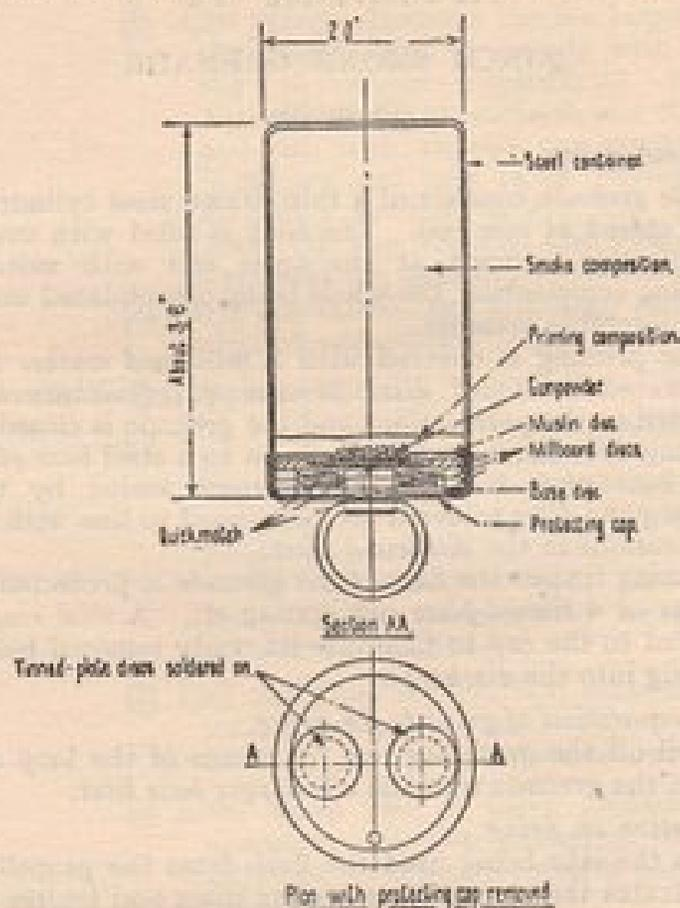
Pull off the *protecting cap* by means of the loop and insert the grenade into the *discharger base* first.

3. Action on firing.

On the rifle being fired the flash from the propellant penetrates the *tinned-plate* sealing discs and ignites the

PLATE 29

GRENADE, 2-INCH, .303-INCH RIFLE, SMOKE



quickmatch. This in turn ignites the priming and smoke composition during flight. On reaching its destination the grenade continues to give off white smoke until all the composition is consumed, a period of approximately one minute.

APPENDIX VII

No. 36 H.E. GRENADE

(Plate 30)

LESSON 1.—MECHANISM

1. Preliminaries.

i. Stores required :—

- 1 Cut grenade with igniter set.
- 1 Dummy No. 36 for each man (with gas check).
- 1 „ Igniter set for each man.
- 1 Base plug key.

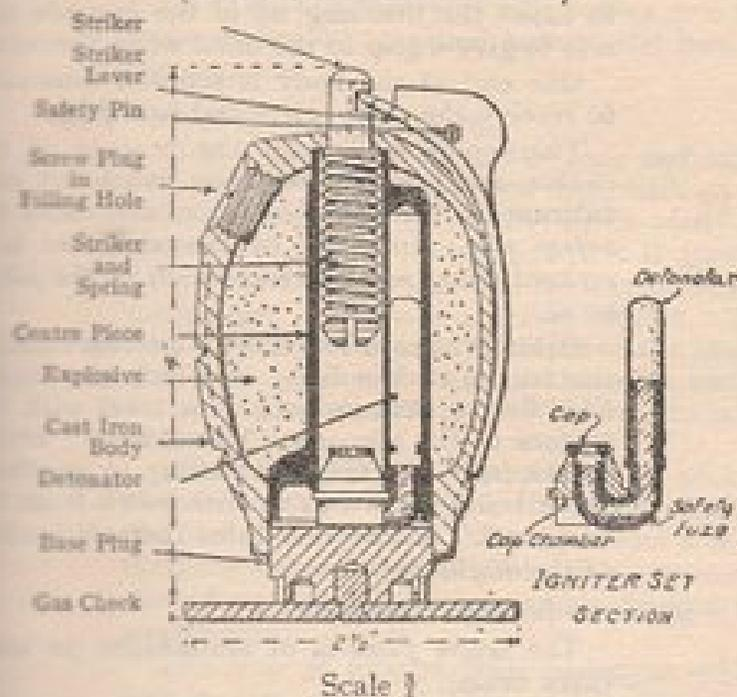
Tables and forms or waterproof sheet.

- ii. (a) Squad seated round a table or any convenient place. Instructor issues grenades.
- (b) Instructor demonstrates *The first safety precaution*. Squad imitates; removing base plug and ensuring grenade is not primed.
- (c) Instructor demonstrates stripping of grenade. Squad imitates.

2. Sequence of instruction.

- i. Instructor states that he is going to describe and teach the mechanism of the No. 36 H.E. grenade. It can be fired from the rifle or thrown by hand. Range when fired 80 yards to 210 yards.

PLATE 30

No. 36 H.E. GRENADE
(WITH GAS-CHECK FITTED)

(The original grenade of this type was invented by Sir William Mills, M.I.Mech.E.)

ii. *Shows cut grenade.*

Describes the body of the grenade.

The weight of the grenade is 1½ lb.

The body of the grenade is oval in shape and is of cast iron; the outside is grooved in order to assist the breaking up of the grenade and also to give a grip to the hand when throwing.

One end of the body is screwed internally to receive the *centre piece* and *base plug*.

The top is drilled for the passage of the *striker*, and has two *shoulders* which act as a fulcrum for the *striker lever* and also carry the *safety pin*. In front of the *shoulders* is a *screwed filling hole* which is closed by the *filling screw*.

Behind the *shoulders* there is a recess running the length of the body in which the *striker lever* lies so that its surface is level with the surface of the grenade. This "flush" fitting of the *lever* prevents it catching in anything when being carried in or withdrawn from the haversack; it also facilitates the safe loading of the *discharger*.

iii. *Describes the centre piece.*

The *centre piece* is of aluminium (in some cases brass).

It is screwed into the grenade from one end and has two sleeves.

The *centre sleeve* contains the *striker* and *striker spring*.

The other sleeve, which is smaller and set alongside the *centre sleeve*, is for the *detonator*; it is closed at the inner end.

The *centre piece* is covered by the *base plug*, which is of the same diameter as the *centre piece* at its broadest part and screws into the same internally threaded hole in the base of the grenade.

iv. *Describes the following parts :—*

Striker, striker spring, striker lever and *safety pin*, assembling each part as described.

The *striker* works in the *centre sleeve* or *striker way* of the *centre piece*; it is formed with a head and neck. The head is slotted to form a *gas escape* and has two *nipples*. The *striker spring* surrounds the neck of the *striker* and bears against the head; the other end of the *spring* bears against the inside of the body of the grenade.

When the *spring* is compressed the neck of the *striker* passes through the hole drilled in the end of the grenade and projects for a short distance beyond; this projecting portion is slotted on one side to receive the end of the *striker lever*.

The *lever* is formed with *trunnions* which rest in grooves on the top of the *shoulders*; one end of the *lever* engages in the slot in the neck of the *striker*, the remainder lies in the recess formed for it in the body of the grenade and is kept in place by the *safety pin* which

passes over the *lever* through holes drilled in the *shoulders*.

The *safety pin* consists of a *split pin* and *ring*.

Instructor teaches safety precautions in connection with cocking, *i.e.* when cocking the grenade, it should be pressed towards the waist belt and not held in such a position as would cause the *striker* to fly off towards the face or towards another person.

v. *Describes base plugs.*

The *base plug* has two recesses formed to receive a special tightening key.

There is a screwed hole in the centre of the *base plug* for the attachment of the *gas check* when firing grenades from the *discharger*.

vi. Squad practises stripping and assembling grenades.

vii. *Shows and describes igniter sets.*

The *igniter set* is composed of a *cap holder* in which is fitted a .22-rim fire cartridge case provided with a *central gas escape* in the base; the *gas escape* is covered with a disc of water-proof paper to exclude damp.

A seven-seconds length of *Nobels buff safety fuse* (No. 16) is fitted into the cap and the joint covered with shellac varnish. The other end of the *fuse* is fitted into a No. 6 commercial *detonator*.

Show how *igniter set* fits into grenade.

viii. *Issues igniter sets* and shows how to prime the grenade.

To prime the grenade, remove the base plug, hold the *igniter set* by the *fuse* end and insert the *detonator* and *cap holder* into their respective *sleeves*. Replace the base plug and tighten it with the key.

ix. Squad practises priming grenades.

x. *Action of the mechanism.*

Instructor with cut grenade complete with dummy *igniter set*, explains, employing question and answer method as far as possible.

If the grenade is held firmly with the *lever* under the fingers and the *safety pin* withdrawn there will be a tendency for the *striker spring* to force the *striker* downwards, to pull down the *short arm* of the *lever*, which is engaged in the *slot* in the *neck*, and to cause the *long arm* to rise. This tendency is resisted by the pressure of the fingers upon the *lever* in grasping the grenade. So long as the *lever* is held the grenade is safe.

On the grenade leaving the hand or rifle the *lever* flies off under pressure of the spring which drives the *striker* down on to the cap (of the *igniter set*), igniting the *fuse*, which burns for 7 secs. and explodes the *detonator* and *charge*. While the *fuse* is burning the gases escape through the escape hole in the cap, the *gas slot* in the *striker*, and the *striker sleeves* to the outer air.

xi. After a gas attack grenades should have their *safety pins* and *working parts* cleaned and re-oiled.

xii. *Describes markings.*

The live No. 36 grenade is varnished on the outside as a protection against rust and is black in colour; a dull red band is painted round the top of the body and over the *filling screw* to denote that the grenade is filled.

The dummy No. 36 grenade is grey in colour, or it may be painted white; there is no coloured band. *Dummy igniter sets* have the detonator nickel-plated and drilled at the end or made of paper tube.

LESSON 2.—POINTS BEFORE FIRING OR THROWING THE NO. 36 H.E. GRENADE

3. *Preliminaries.*

i. *Stores required :—*

- 1 Dummy 36 for instructor and each man.
- 1 „ Igniter set for instructor and each man.
- 1 Gas check.
- Luting.

ii. Prepare seats as required. Issue dummy grenades and cause the *first safety precaution* to be carried out. Issue gas checks.

4. *Sequence of instruction.*

i. Instructor states object of lesson is to teach the points to which attention must be paid as a

preliminary to their preparation for use, in order to guard against—

- (a) Defects which might cause a premature explosion.
- (b) Defects which might cause blinds or weak explosions.

ii. Instructor will explain fully each point to be examined, the class following and inspecting their own grenades as each is mentioned.

The following are the points which will be examined :—

No. 36 Grenade.

Precaution

Reasons

- | | |
|--|--|
| (a) Remove the <i>base plug</i> and examine the interior of the grenade. | To make sure that the grenade is "safe," i.e. that it is not <i>primed</i> . |
| (b) Examine the outside of body for cracks, beginning at the <i>base</i> . | A cracked body might allow damp to penetrate and cause a blind. It might also cause the grenade to break up in the <i>discharger</i> when fired. |
| (c) Examine the <i>filling screw</i> to see that it is properly home and sealed. | A loose screw might allow damp to penetrate and cause a blind. |
| (d) Examine the <i>shoulders</i> to see that they are not broken. | A broken <i>shoulder</i> might result in premature release of the <i>striker</i> . |

- | <i>Precaution</i> | <i>Reasons</i> |
|--|--|
| (e) Examine projecting portion of <i>striker</i> to see that it is properly sealed with wax and that the <i>lever</i> is correctly engaged. | Defective sealing might allow damp to penetrate. |
| (f) Examine the <i>ring</i> and <i>safety pin</i> to see that they are sound and that the <i>lever</i> is properly held. | To facilitate the use of the grenade. |
| (g) Examine the <i>lever</i> to see that it is properly fitted in the <i>shoulders</i> and that its <i>long arm</i> fits close to the <i>body</i> of the grenade. | A projecting <i>lever</i> might catch in the <i>ring</i> of another grenade when taking it from the haversack, or might catch on the edge of the <i>discharger</i> when loading, and therefore be dangerous. |
| (h) Apply the <i>striker test</i> as follows:—
(i) Close the points of the <i>safety pin</i> to facilitate withdrawal.
(ii) Hold the grenade as for throwing and remove the <i>pin</i> .
(iii) Placing the <i>base</i> of the grenade against the waist belt, allow the | This test ensures that the whole of the <i>striker mechanism</i> is in working order, that the <i>striker</i> is free to move.

A <i>jammed striker</i> may cause a dangerous blind. |

- | <i>Precaution</i> | <i>Reasons</i> |
|--|--|
| <i>striker</i> to fall; remove the <i>striker</i> and <i>spring</i> from the grenade.
(iv) Take the <i>striker</i> from its <i>spring</i> , remove any undue grease from the <i>striker</i> and place it in the grenade, see that it works perfectly freely in the <i>striker way</i> . | Any grenade in which the <i>spring</i> appears weak, or in which the mechanism seems to work stiffly, should on no account be used. |
| (j) Examine the <i>centrepiece</i> to see that it is not cracked and is clean; see that the two <i>sleeves</i> are free from corrosion, dirt or dents, &c. Particularly look for holes or cracks in the wall between the two <i>sleeves</i> . | Dirt, &c., might prevent the insertion of the <i>igniter set</i> or cause jamming of the <i>striker</i> . Cracks in the <i>centrepiece</i> might allow a flash from the <i>cap</i> to pass direct to the <i>detonator</i> and cause a premature. |
| (k) Examine the face of the <i>striker</i> . See that it has two <i>nipples</i> and a <i>gas slot</i> . | The absence of a <i>gas slot</i> might cause a rise of pressure which would result in a rapid burning of the <i>face</i> , or even "flashing over," and cause a premature. |
| (l) (i) Reassemble the <i>striker mechanism</i> and recock, using a cartridge or empty case to compress the <i>spring</i> . | |

<i>Precaution</i>	<i>Reasons</i>
(ii) Press down the lever, replace the pin with ring uppermost when grenade is held correctly for throwing, and open out the points sufficiently to ensure safety, but not so far as to prevent removal of the pin in use.	
(iii) Replace the base plug.	
(iv) If preparing for firing fit the gas check to the base plug.	To ensure correct fitting.
(v) Remove gas check and return grenade to box.	

5. Inspection of igniter sets.

- i. Instructor will place grenades away from detonators. Issue dummy igniter sets and luting.
- ii. State object is to teach how to examine and prepare for use, and that grenades and their igniter sets will never be inspected together, to avoid the possibility of the grenade becoming primed.
- iii. When inspecting igniter sets they must be held by the cap holder and fuze rather than by the detonator. Care must be taken that the

detonator is not *struck, crushed, or bent*, nor subjected to *heat or friction*. On no account must the igniter set be dismantled.

iv. Holding the igniter set by the cap holder and fuze.

<i>Precaution</i>	<i>Reasons</i>
(a) Examine the cap; see that it has a central gas escape and that this is covered with a disc of waterproof paper.	Absence of a gas escape might result in "flashing over" and cause a premature. Absence of the waterproof disc might have allowed damp to penetrate. In peace training the igniter set should not be discarded if this disc is absent.
(b) See that the cap is properly fitted in the cap holder.	
(c) See that the fuze is buff coloured; that it is firmly fixed and that the joint is shellaced.	
(d) See that the detonator is firmly crimped to the fuze.	
(e) Lute the joint between the fuze and detonator with luting or mud.	To exclude the possibility of a flash from the cap penetrating direct to the detonator and causing a premature.

(f) Return igniter sets to box.

v. *Preparation for use.*

Preparation for use consists in fitting the igniter set to the grenade. In peace time this must only be done in the priming bay of the live practice trench immediately before firing or throwing.

**Special instructions for firing live
No. 36 Grenades**

6. See Secs. 24 and 28, General Instructions.
7. Special Instructions.

Accidental release of striker when firing

Grenade remains in *discharger* with *fuse* burning. In this case, rifle and grenade together must be thrown over the parapet at once and cover taken. No attempt must be made to save the rifle. The N.C.O. on duty must be prepared to take such action as may be necessary to ensure safety. This occurrence is generally attributable to defective ballistite grenade cartridges; the pressure produced—particularly with an open *gas port*—is just sufficient to lift the grenade nearly out of the *discharger* so that the *lever* is set free; the grenade then slips back into the *discharger*. Variations of this may occur, the grenade may be forced from the *discharger* and fall into the bay. In such a case no attempt will be made to pick up the grenade. The occupants of the bay will at once take cover round the traverse and leave the grenade to explode. Should the firer show hesitation

or lose his head under such circumstances, the N.C.O. on duty must be prepared to act instantly and with energy. He will be the last to leave the bay. The *time fuse* of 7 seconds gives ample time for the clearing of the bay.

**Special instructions for throwing live
No. 36 Grenades**

8. See Secs. 25 and 28, General Instructions.
9. Special Instructions.

Grenade dropped with pin out.

It may happen occasionally that a clumsy or nervous man will drop a grenade when in the act of throwing. In such a case the action will be the same as that taken in firing, when a grenade has been freed from the *discharger* and has fallen into the bay.

APPENDIX VIII

2½-INCH DISCHARGER (Plate 31)

Description.

- i. The *barrel* is cylindrical in shape, made of steel, and is large enough to contain a grenade. The outside is roughened to give a grip for the hand when fixing. The lower end of the *barrel* is cone-shaped and of smaller bore; it is threaded internally to receive the *locking base*. Near the lower end is a *slot* which forms the *gas port*. This is closed by a *sliding shutter* which can be clamped in certain positions by a *clamping nut*. On the inside of the *barrel* there is a *shelf*; the *shutter* and the *shelf* together form a seating for the grenade when in the *discharger*.
- ii. The *locking base* is threaded on the outside to fit the barrel and with a central *hole* threaded to receive the *adjusting screw*, the top of which is slotted to take the point of the bayonet. Below are two *lugs* in which are pivoted the *claw levers*; these engage in the slotted sides of the *nosecap*.

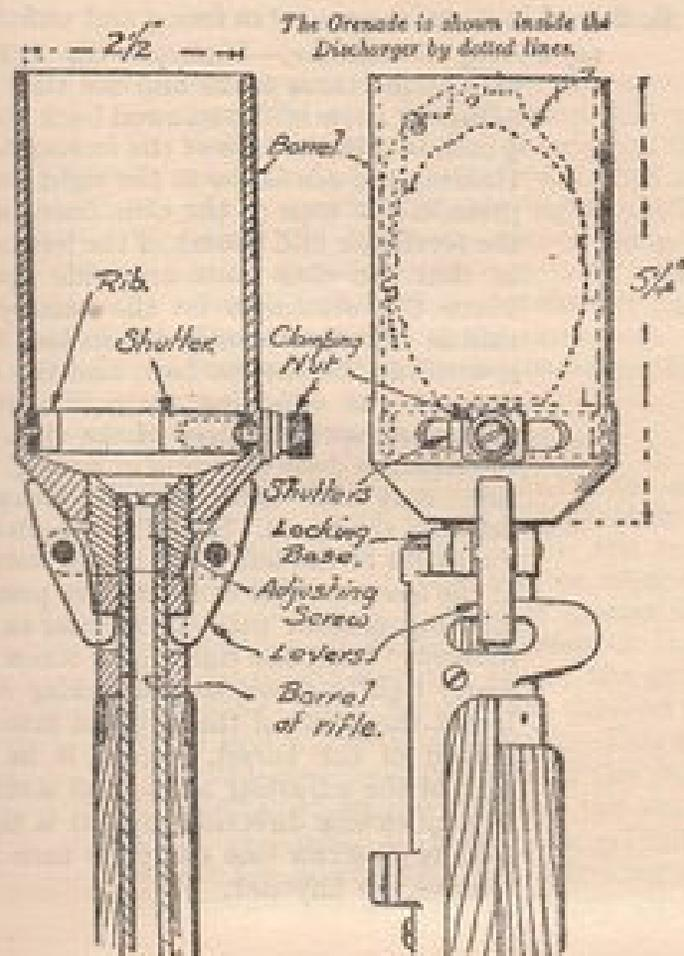
LESSON

I. Preliminaries.

- i. *Stores required.*—1 discharger for each man, 1 dummy ballistite grenade cartridge.
- ii. Inspect arms and dummies. Issue dischargers.

PLATE 31

2½-INCH DISCHARGER—FOR ATTACHMENT TO RIFLES, No. 1



2. *Sequence of instruction.*

i. Give complete demonstration of fixing and unfixing.

ii. Squad imitates instructor in fixing and unfixing.

(a) *Fixing Discharger.*—Unscrew the *locking base* about three turns and see that the *adjusting screw* is also screwed back about $\frac{1}{4}$ inch within the face of the *locking base*. Holding the *discharger* in the right hand, press in the tops of the *claw levers* with the forefinger and thumb of the left hand so that the *claw ends* are wide apart. Place the *discharger* on the *nosecap* of rifle so that the *recess* in the *locking base* is towards the *bayonet boss*, and the *hole* through the *adjusting screw* in correct alignment with the *bore* of the rifle. If the fixing is done standing or sitting, the rifle may be held barrel outwards between the knees. Slide the thumb and forefinger of the left hand to the bottom of the *levers* so that the *claws* are pressed into engagement with the *recesses* in the *nosecap*. With the right hand screw the *barrel* tightly down to the *locking base*. Insert the point of the bayonet into the mouth of the barrel, engage it in the slots of the *adjusting screw*, and screw it in a clockwise direction until it is tight. Finally unscrew one complete turn and remove the bayonet.

Instructor explains that the unscrewing of the *adjusting screw* one complete turn after fixing to a cool barrel is to allow for the expansion of the barrel by heat.

(b) *Unfixing Discharger.*—Grip the *nosecap* of the rifle with the left hand and at the same time press inwards with the thumb and forefinger on the lower ends of the *claw levers*. With the right hand, unscrew the *discharger* two or three turns in an anti-clockwise direction; slide the thumb and forefinger of the left hand to the upper ends of the *claw levers*, press inwards and raise the *discharger* off the *nosecap*.

iii. Squad practises. Instructor checks.

iv. *Range-setting.*—When firing H.E. or smoke grenades, the barrel of the rifle must be kept at an angle of 45 degrees. In the case of signal grenades, the rifle will be held at an angle of 70 degrees. Longer or shorter ranges will be obtained by adjustments of the *gas port*. To obtain extreme range, the *gas port* will be fully closed, while for the shortest range the *gas port* will be fully opened. This is due to the fact that the gases behind the grenade are allowed to escape through the *gas port* instead of having to follow the grenade up through the *discharger*. The following range table shows the average distances that the

H.E. grenade will be fired for the various adjustments to be made in the *gas port* :—

<i>Gas port</i>	<i>Range</i>
Fully open	80 yds.
$\frac{3}{4}$ open	110 ..
$\frac{2}{3}$ open	140 ..
$\frac{1}{2}$ open	170 ..
Fully closed	200 ..

As there are no graduations on the *gas port*, the firer will have to judge the position of the *shutter* when adjusting the *gas port* to the different amounts of opening.

- v. Squad imitates setting ranges. Loosen *clamping screw*, move *shutter* to position required, and tighten *clamping screw*. The measurement must be taken between the inside edge of the *shutter* and the end of the *gas port*.
- vi. Squad practises setting ranges by word of command. Instructor checks.
- vii. *Care and Cleaning*.

- (a) *Daily*.—Wipe over all parts with slightly oiled rag, leaving the *bore* of the *adjusting screw* and the *thread* of the *locking base* slightly oiled.
- (b) *After firing*.—Remove the *locking base*: unscrew *adjusting screw*; wipe inside of *barrel* and surfaces of *shutter* with dry rag to remove superficial fouling. Then thoroughly clean with slightly oiled rag, wipe dry, and re-oil. Thoroughly clean

locking base and *adjusting screw* in the same manner, paying particular attention to *threads*.

- (c) After a gas attack the *discharger* should be cleaned and oiled.

viii. Safety precautions.

- (a) *Ballistite grenade cartridges* only will be used. It is distinguished from other blank by being blackened for half its length from the mouth.
- (b) The use of *ball ammunition* for firing a grenade is strictly forbidden. Only in great emergency at very close range may ball ammunition be fired through the *empty discharger*.
- (c) During the firing of a number of grenades there is a possibility of the *discharger* working loose. It should, therefore, be examined after firing two or three grenades, and readjusted on the rifle if necessary.

APPENDIX IX

ANTI-AIRCRAFT LIGHT AUTOMATIC
ACCESSORIES

1. Description of A.A. sights.

- i. *The backsight* (known as "Sight, back, A.A. Mark II") is an aperture of $\frac{1}{2}$ -inch diameter, fixed in position on the leaf of the ground aperture backsight of the gun.
- ii. (a) *The foresight* (known as "Sight, fore, A.A. Mark II") consists of two elliptical rings, one inside the other, with a bead in the centre, and is capable of being moved along the gun.
 - (b) The distance between the foresight and the backsight is 31.2 inches.
 - (c) (i) The following general rule is given for the use of the foresight:—

For all aircraft flying at an angle of sight of over 25 degrees, use the outer ring.

For all aircraft flying at an angle of sight of 25 degrees and under, use the inner ring.
 - (ii) The following rule will be used as a guide as to whether the angle of sight is over or under 25 degrees:—When the leg

clamping screw of the Lewis gun bipod is level with the top of the A.A. mounting, the angle of sight to the target is 25 degrees. The bipod legs must be left hanging and not folded during A.A. fire.

2. Method of fixing the sights.

- i. *The backsight* is fixed permanently to the top of the tangent sight.
- ii. It consists of two main portions. The larger portion, which contains the sighting aperture, is placed on the graduated side of the tangent sight leaf, with the block fitting into the recess at the top of the leaf. The sighting aperture is kept uppermost. The smaller portion, together with a spring washer on the outside, is placed on the other side of the leaf, and the whole is then screwed together.
- iii. *The foresight* is fixed on to the rear radiator casing by a spring steel ring, secured by a vice pin nut. A pointer is attached for aligning with the foresight of the gun. The spring steel ring should fit closely against the rear edge of the clamp ring, and the vice pin screw should be on the right side of the gun.
- iv. To affix the foresight to the gun. Slide the foresight over the front radiator casing, the rings towards the ground, and the vice pin screw to the LEFT of the gun. Slide the sight along the casing until it is behind the clamp ring. Then twist it round until the rings are uppermost. Press it up tight to the clamp ring and screw

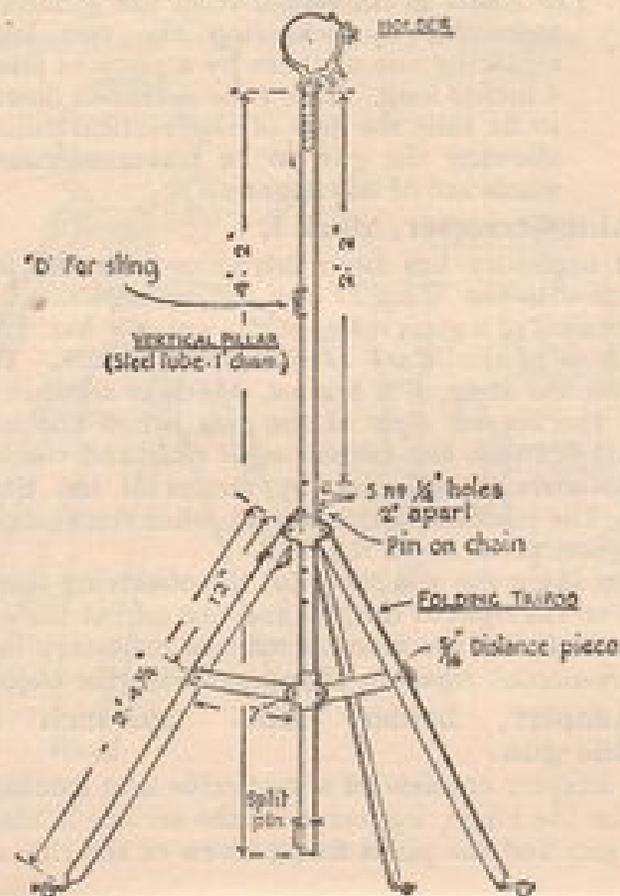
until there is no chance of slipping. When screwed up, the pointer on the foresight should be in exact alignment with the foresight on the gun.

- v. Great care must be taken in putting on and removing the foresight that the spring steel ring is not strained in any way.
- vi. The foresight will be kept permanently on the gun. When not in use it should be folded back flat on the radiator casing.

3. The anti-aircraft portable mounting.

- i. Details of the construction of this mounting are shown in Plate 32. It consists of three main parts:—
 - (a) Folding tripod.
 - (b) Vertical pillar.
 - (c) Holder (-303-inch M.G. Lewis A.A.).
- ii. *The folding tripod.*—The legs of the folding tripod are hinged to two gun-metal collars which slide on the lower part of the vertical pillar. Distance pieces $5/16$ " thick are inserted between the hinges, to enable the legs to fold flat.
- iii. *The vertical pillar* is formed of steel tubing, 4 ft. 2 in. long, and 1 in. external diameter. Five holes are drilled through the lower part, and a pin is provided which rests on the upper gun-metal collar of the tripod. By this means the height of the mounting can be adjusted. Two "Ds," for a sling, are riveted into the pillar, one at the bottom end, and the other

PLATE 32
ANTI-AIRCRAFT PORTABLE MOUNTING



14 inches from the top. In addition, a split pin is provided just above the lower "D" to prevent damage to the latter.

- iv. *The holder is converted from the ground bipod mounting by removing the two legs and replacing one of them by a piece of steel tube 4 inches long. This tube is turned down so as to fit into the top of the vertical tube, thus allowing the gun to be traversed round the whole arc of 360 degrees.*

4. Aim Corrector, Mark I.

This accessory has been introduced for use in conjunction with the *Mark II anti-aircraft sights*.

It consists of a glass *reflector* in a *reflector box*, identical with those of the *Mark II rifle aim corrector*. The box slides on the stem of a *bracket*, which is secured to the *leaf* of the *tangent sight* of the gun (when the latter is upright) between the *tangent sight slide* and the base of the *anti-aircraft backsight*, by means of the *elevating screw*. The position of the *bracket*, when fixed, should be the highest possible on the *leaf*.

When using the *aim corrector*, the observing instructor will be on the right of the gun and can adjust the *reflector box* vertically on the stem as may be necessary to bring the *anti-aircraft sights* in alignment with the objective.

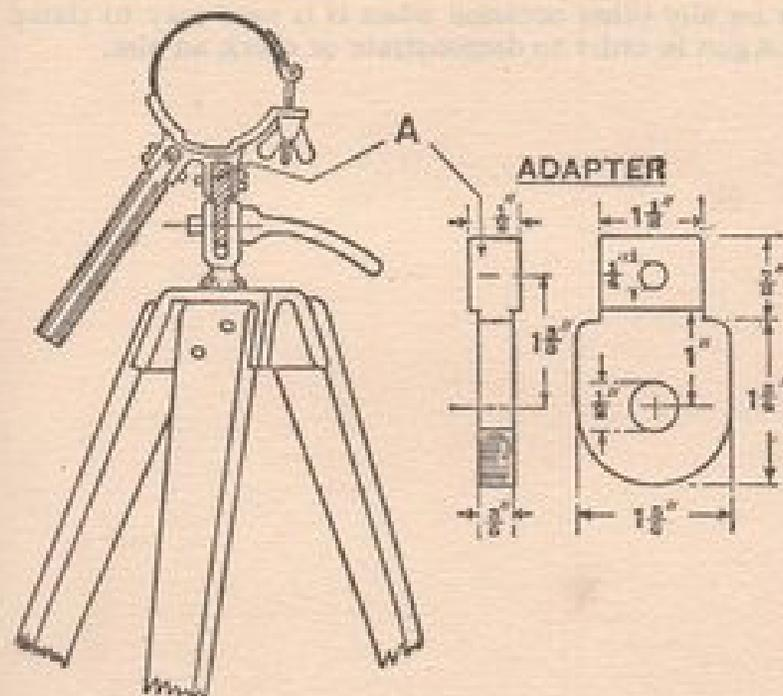
5. Adapter, holder, A.A. .303-inch Lewis machine gun.

The adapter consists of a malleable iron casting with holes for the hinge, leg, screw of the service holder A.A. Lewis gun and the pivot fixing screw of the rifle aiming rest.

The top edge "A" (*see* Plate 33) of the adapter is

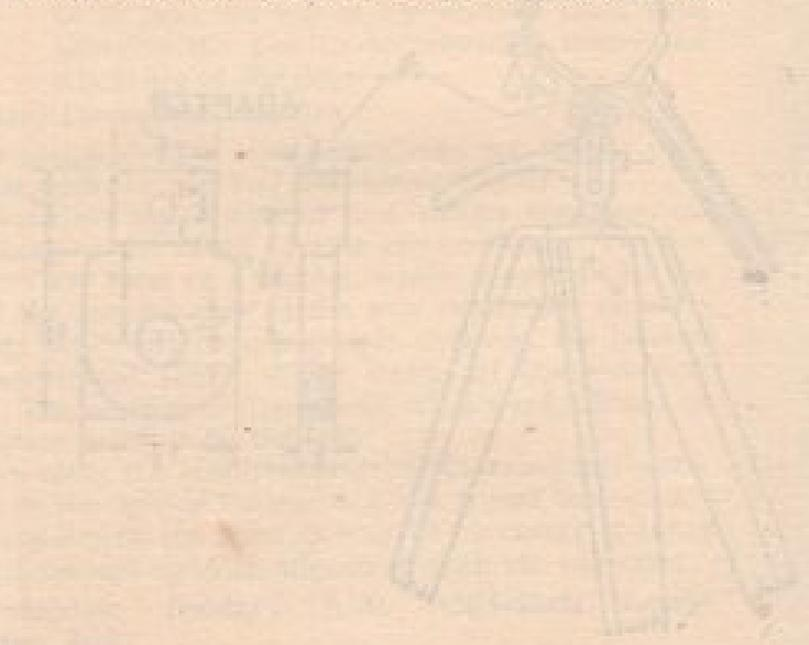
PLATE 33

AIMING REST ADAPTED TO TAKE A LEWIS GUN



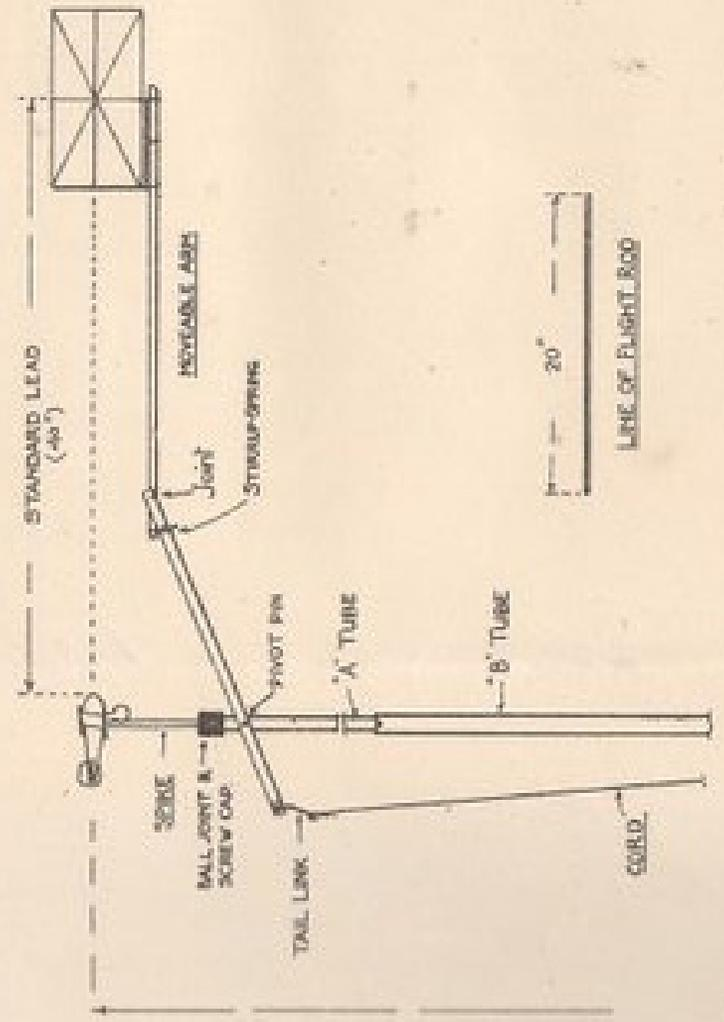
fitted to the holder to ensure a rigid joint when clamped with the hinge screw. The lower portion of the adapter is reduced in width for assembly to the pivot of the aiming rest.

The adapter enables the Lewis gun to be mounted on the rifle aiming rest for use with the Spotlight Projector or on any other occasion when it is necessary to clamp the gun in order to demonstrate or check an aim.

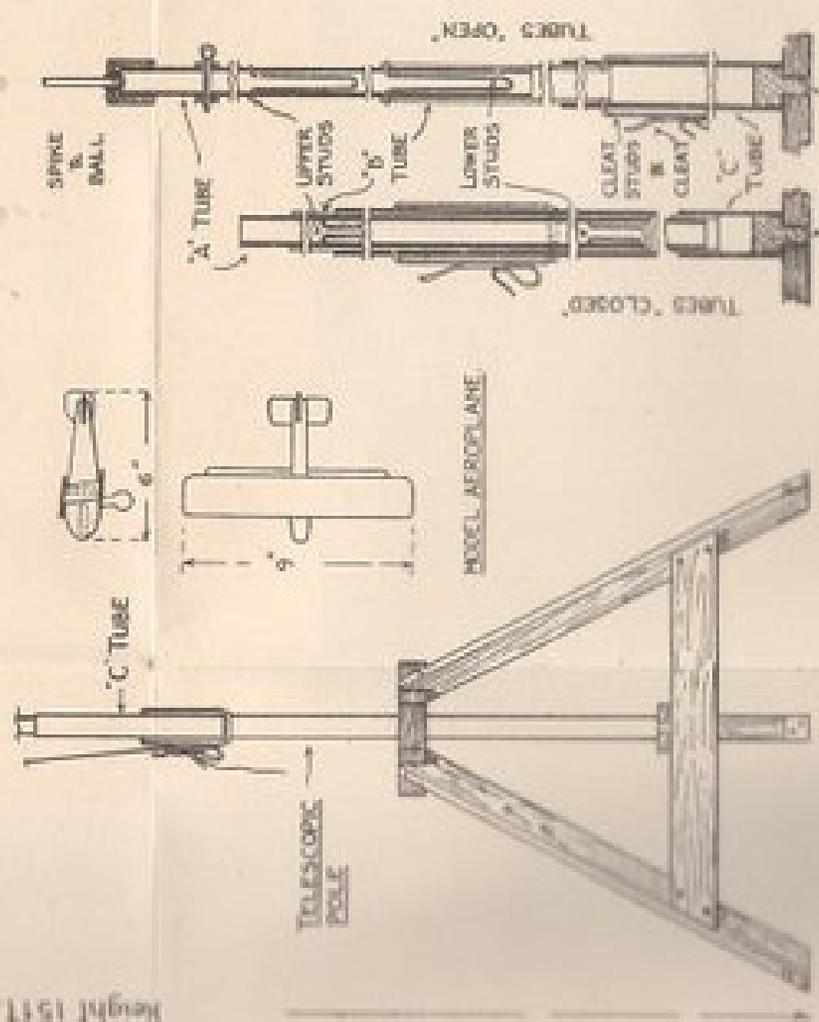


(To face page 343.)

PLATE 34.
MODEL AEROPLANE WITH POLE AND STAND



Weight 157



4-1111

Making & Serv. Patent-UK.

APPENDIX X

SMALL-ARM ANTI-AIRCRAFT TRAINING
APPLIANCES

1. Aids for training in recognition.—These consist of:—

i. *Diagrams* to be affixed to walls of barrack rooms, &c. These diagrams show:—

(a) Various aspects of certain types of aeroplanes. As new types are introduced fresh diagrams will be issued to replace those which become obsolete.

(b) British national markings.

ii. *Cards* for standard test in recognition. Each card gives two aspects of one of the types shown in sub-para. i (a) above, and will be used in accordance with instructions in Sec. 55, 4.

2. Model aeroplane with pole and stand (Plate 34).

General description.

i. The apparatus consists of a pole, 15 feet high, upon which is mounted a small-scale model of an aeroplane, and a movable arm carrying a wire rectangle which can be placed so as to appear to be directly in the line of flight of the aeroplane, and at a suitable distance ahead of it to represent the distance through which the aeroplane would travel during the

- flight of a bullet fired at it. For crossing aeroplanes the wire rectangle should be slightly above or below the horizontal, so as to appear to coincide with the line of flight of the aeroplane as shown by the line of flight rod.
- ii. The pole is held vertically in a wooden stand.
 - iii. The pole is made of steel tubes in three sections, which can be closed like a telescope to a length of a little over 5 feet.
 - iv. The aeroplane model is empaled upon a spike which surmounts the pole. This spike is mounted on a ball which is clamped by means of a screwed cap to the top of the pole.
 - v. Thus the spike can be inclined at any angle within wide limits so that the model aeroplane may appear to be climbing or diving, or the aeroplane may be slewed round upon the spike so as to appear to be flying towards or away from the firer at any desired angle. The movable arm and rectangle when in use must always be at right angles to the firer.
 - vi. The arm which carries the rectangle is pivoted upon the pole, so that it can be dropped while a rifle is being laid upon the target, and then raised so that the "lead" may be checked by comparison with the centre of the rectangle.
 - vii. When this apparatus is used for A.A.L.A. instruction the movable arm and rectangle are not required, as aim is checked by means of the aim corrector.

3. Projector, Spotlight (Plates 35 and 36).

- i. This is a device of the flash-lamp type arranged for clamping to a weapon and so constructed optically and mechanically that a spot of light can be projected on to the target to indicate the point where a shot fired would strike. The control of the light is in the hands of an instructor or observer other than the firer of the weapon by means of a flexible cable and a switch. The correctness, or otherwise, of aim and trigger release can thus be checked. The apparatus is divided into the following main parts:—

Projector,
Brackets,
Switch and connections,
Battery.

The whole is packed in a box.

- ii. *Projector* (Plate 35).—This consists of a brass tube (A), about 6 inches long, fitted with a lens (B) at one end. In the other end is an inner tube (D) which can slide to enable the spot of light to be focussed, and is secured by a milled screw (E). A screwed cap (F) fits into the sliding tube (D), and carries the bulb (C) and terminal wires. The projector is held in a clamp (G) which has a hinge (H) and a thumb-screw, by means of which it can be attached to the brackets on the rifle or the Lewis gun.
- iii. *Bracket*.—The form of this component varies with the weapon to which it is to be fitted.

PLATE 35

PROJECTOR, SPOTLIGHT

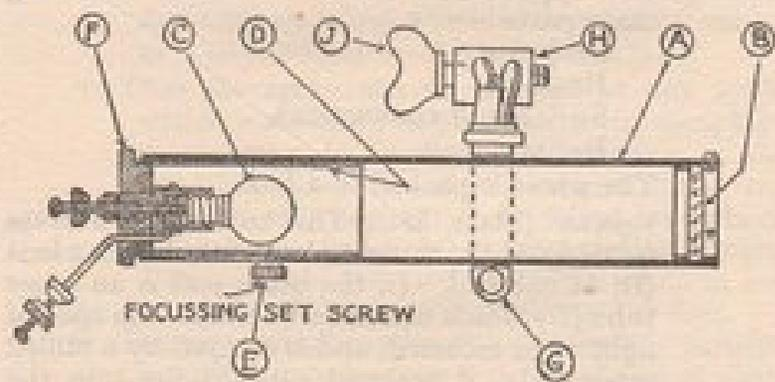


PLATE 36

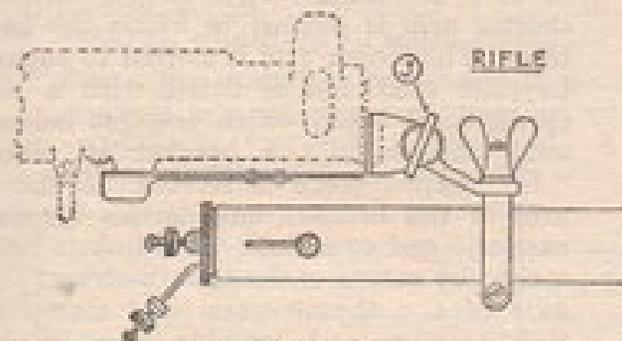
PROJECTOR, SPOTLIGHT, BRACKET ATTACHMENTS
FOR RIFLE AND LEWIS GUN

FIG. 1

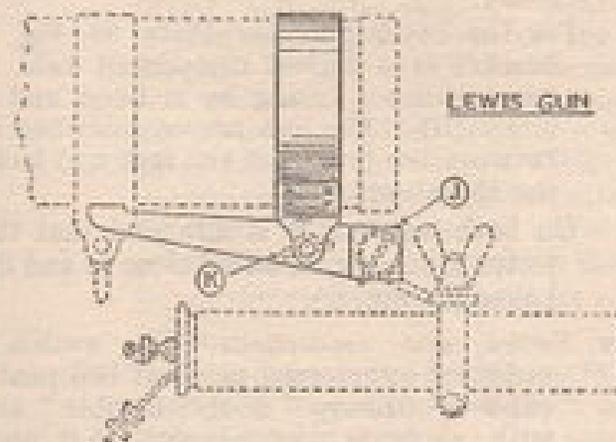


FIG. 2

In the case of the rifle No. 1, Mk. III (*see* Plate 36, Fig. 1), it is arranged to fit on the noscap in place of the bayonet. It consists of an "L"-shaped steel strip of which the shorter arm is pierced to fit on the bayonet boss. The longer arm is slotted to engage the bayonet stud and is fitted with a pivoted spring steel catch which engages behind the stud and holds the bracket in place. A "U"-shaped piece is riveted to the short arm of the bracket and carries between its ears one end of a link. The link is held and locked by means of the thumb-screw (J). The axis of the thumb-screw and clamp are at right angles and provide respectively for vertical and lateral adjustments of the projector.

For the Lewis gun (*see* Plate 36, Fig. 2) the bracket is a forked component held to the front radiator casing by a band and clamp screw (K). The link above described is held between the prongs of the fork and locked by the thumb-screw (J).

On both weapons it is intended that the projector should be mounted close to and directly below the muzzle.

- iv. *Switch and connections.*—The switch is an ordinary commercial pendant bell-push. The cable is ordinary "double flexible" arranged with two branches respectively 5 ft. and 12 ft. in length for connection to battery and pro-

jector. Each branch of the cable terminates in a pair of brass tabs for connection to the projector and battery terminals.

- v. *Battery.*—This is composed of four cells, dry X Mk. II, connected in series giving six volts.
- vi. *Box.*—The complete apparatus is packed and carried in a wooden box provided with compartments for each component. A wiring diagram is pasted inside the lid.
- vii. *Use of projector.*
- (a) *Assembling.*—The clamp and link, being for use with any of the special brackets, will normally be attached permanently to the projector, the former being firmly fixed by means of its screw, using a screw-driver, the latter held by means of its thumb nut. Whichever of the special brackets is required can then be assembled and secured by the thumb-screw. The completely assembled apparatus will then be attached to the weapon. When securing the clamp to the projector, care should be taken that the locking screw for the inner tube is in such a position that it can be conveniently manipulated for adjusting focus.
- (b) *Connecting up.*—The flexible cable has two branches, long and short, each having a pair of tabs at the ends. One pair of tabs is for connection to the terminals of the

projector, the other pair for connection to the outer terminals of the battery. Either tab of a pair may be connected to either of the two terminals, and it is a matter of convenience whether the long or the short branch of the cable is connected to the projector or battery respectively. The cells composing the battery should be connected in series with one another with suitable wire, as shown in the wiring diagrams. If all connections have been properly made and all is in order, the projector lamp should light up when the switch is pressed. If it fails to do this, the apparatus must be tested in the manner described in sub-para. (e).

- (e) *Aligning and adjusting.*—The apparatus being attached and all connections made, the weapon—if a rifle or Lewis gun—will be fixed in an aiming rest or other suitable support and the sights carefully aligned on an aiming mark placed at some convenient distance between five yards and ten yards from the lens of the projector. The switch will then be pressed to light the lamp and the projector roughly aligned on the target by slacking off the clamp nut and link screw and moving the projector as required. The focus will then be adjusted by loosening the locking screw and moving the inner tube inwards or outwards until the spot of light is most

clearly defined. This having been done, the locking screw will be tightened. Then, without disturbing the alignment of the sights, carefully align the projector so that the spot of light strikes the target at the point desired. Finally, tighten the clamp nut and link screw. The projector is now registered. The point of impact of the light spot on the target is not necessarily the point on which the sights are aligned; it may be some other point chosen to represent deflections of aim for movement, wind, &c. It must be remembered that, owing to the line of sight and the axis of the projector being some distance apart, a given alignment of the projector will only be correct so long as the range is unchanged. The permissible variation of range for one setting of the projector is a few inches only.

- (d) *Points in use.*—The projector is intended in a general way to provide an instructor with a means of checking correctness of aim, trigger release, judgment of deflection, &c. It is, therefore, arranged so that the light is under the control of the instructor or some person other than the man using the weapon. The check is given by the position or movements of the spot of light flashed intermittently on the target for brief spaces of time. If the light is kept on too long the firer may be

able to use the light spot as a means of aim instead of the sights. Details for the use of the projector for particular purposes are given in the appropriate places elsewhere in the manuals concerned.

- (c) *Care and testing.*—If the lamp fails to light when connected up as described in sub-para. vii (b), the cable and all connections should first be examined to see that there is no breakage, that terminals and tabs are clean and free from corrosion and tightly connected. If these points appear in order the battery should be tested by connecting a spare bulb directly across it. If it burns brightly the cable should be tested by detaching the tabs from the projector and holding them in contact with the same bulb. If this again lights when the switch is pressed the fault probably lies in the projector, *i.e.* the bulb is defective or there is a fault in the inside connections. The spare bulb should, therefore, be put in, to do which, the cap should be unscrewed from the end of the sliding tube. If it is then found that the bulb is loose in the holder, it should be screwed in tight and again tested. The bulb can then be unscrewed and replaced by the spare. Finally, retest. Any faults which cannot be located by this method of elimination should be dealt with by the Armourer.

The ordinary care of the apparatus consists in seeing that terminals are kept screwed finger tight, that contact surfaces are clean, and that the flexible cable is not allowed to become frayed or broken. Care must also be taken that the battery is not short-circuited. The projector itself should be treated with the same care as a field-glass.

4. List of components.

Projector

Bulb, 6 volt, 3 watt, Cossor (special).
 Cap, with terminals long and short, 4 nuts, sleeving, sleeve, washer, lamp socket, screw and fibre nut.
 Lens.
 Ring, securing lens.
 Screw, locking tubes.
 Screws, ring (3).
 Tube, inner.
 Tube, outer, with lens seating.
 Clamp with screw, nut, washer, link and screw, link (common to all brackets).

Brackets

Bracket, gun, Lewis with band, spring and screw.
 Bracket, rifles, No. 1 or No. 2, with spring catch.

Switch

Switch (bell push) with flexible cable and 4 tabs.

Battery

Cells, dry, X, Mk. II (4).

Box

Box with wiring diagram pasted inside lid.

5. Moving target for spotlight projector (Plate 37).

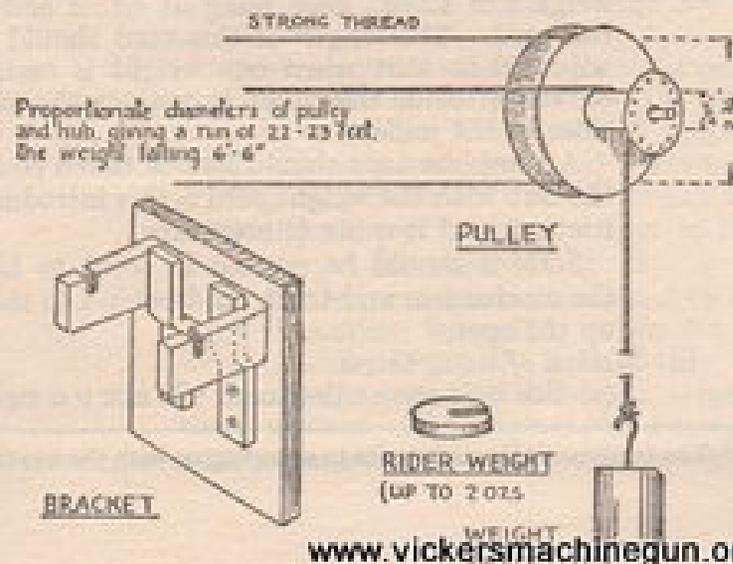
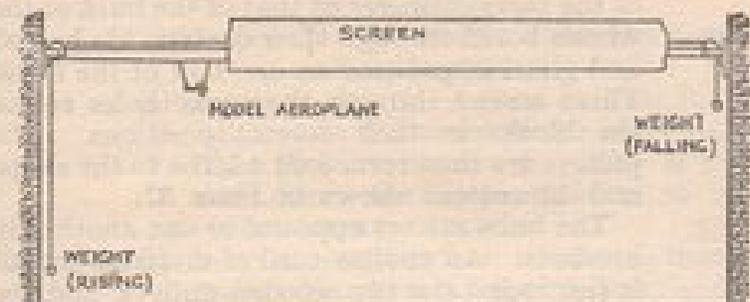
- i. The target described below has been designed for use indoors with the spotlight projector. It is capable of a considerable range of speeds, which can be varied from $1\frac{1}{2}$ feet per second up to about 6 feet per second. In addition, it can be used at angles other than the horizontal, in order to give a diving effect to the target. It is easily reversible; only a short time is necessary to change the weights and reverse the model aeroplanes.

The most suitable ranges at which to use the target are 10 yards and $7\frac{1}{2}$ yards, both from the point of view of the spotlight projector and the best speeds of the target.

The model aeroplane should be as light as possible. It should be 6 inches long and $8\frac{1}{2}$ -inch wing span. Stiff drawing paper is the best material for the purpose. The most suitable length of run is 20-24 feet, but this may have to be shortened when the run is not horizontal if insufficient vertical drop is available at one end of the run.

PLATE 37

MOVING TARGET FOR SPOTLIGHT PROJECTOR.



ii. *Description of target.*—Two front-wheel hubs and spindles of an ordinary bicycle form the pulleys for the target. The oiling caps are removed. Round blocks of wood, with holes of the same diameter as that of the hubs of the wheels bored through their centres, are halved and glued in position on one half of the hubs. Three screws through the spoke holes retain the blocks in their correct positions. The pulleys are then turned on a lathe to the shape and dimensions shown in Plate 37.

The hubs are set opposite to one another in brackets. An endless cord of mattress thread is run round the two wooden pulleys, and the model aeroplane is hung on the lower thread. A second cord, also of mattress thread, is run over the metal part of the hubs, with two weights of 12 oz., each hung at either end of the cord. The length of this cord should be adjusted so that when one weight is resting on the ground, the other is against the stop close to the pulley.

A complete turn should not be taken round the hub with the weight cord; this introduces friction, and is quite unnecessary.

Screens should be erected in front to hide the mechanism and track, and behind to show up the spot.

iii. *Method of using target.*

(a) See that the endless cord * is not too tight.

* The tension of this cord varies to some degree with the weather.

A tight cord increases the friction in the hubs. The results of this are :—

- (i) Jerky movement.
 - (ii) A large bias is required to move the model (*see (c)*).
 - (iii) It is impossible to run the target at a very low speed.
- (b) See that plenty of play (1/16th inch) is allowed in the cones of the bearings, and that they are kept well oiled. If this is not done, the same defects, as given under (a), are obtained
- (c) Arrange the two 12-oz. weights so that one, called No. 1, is at the highest, and the other, called No. 2, is at the lowest point of its run.
- (d) Fix the aeroplane to the lower part of the endless cord at the end near the No. 1 weight.
- (e) Add rider weights to the No. 1 weight until the aeroplane moves. Add small rider weights to the No. 1 or the No. 2 weight, until the required speed is obtained. Adding weight to the No. 1 weight increases the speed. Adding weight to the No. 2 weight decreases the speed.
- (f) After the run, return the aeroplane to its original position by pulling down No. 2 weight, not by lifting No. 1 weight.
- (g) To reverse the direction of the run, reverse the aeroplane. The original No. 1 weight now becomes No. 2 weight, and vice versa.

- iv. As the object of the practice is to teach and detect faults in a uniform steady swing, the speed of the target is of no great importance, but the speed should be increased as the squad becomes more efficient. An ultimate speed of 6½ feet a second with the gun at 10 yards' range represents an aeroplane at 400 yards at 180 m.p.h.

INDEX

Note.—No reference to instructional details of Lessons or Drill is made in this index. Headings of sections dealing with such details will be found in the Table of Contents.

A.

	PAGE
Adapter, holder, A.A. for Lewis gun	340
Ammunition .22-inch, firing: considerations	102
Anti-aircraft—	
— Appliances for small-arms training	343 <i>et seq.</i>
— Light automatic: accessories	336 <i>et seq.</i>
— Portable mounting for L.A.	338 <i>et seq.</i>
— Small-arms, T.O.E.T.	230 <i>et seq.</i>
— Training, small-arms	176 <i>et seq.</i>
Aim corrector for A.A.L.A., description and use	340
Aircraft—	
— Ranging on: training in	181
— Recognition: training in	180
Air sentries, training of	183
Attack—	
— Air, methods of hostile	176 <i>et seq.</i>
— „ warning of	183
— „ „ signals to be used	183

B.

Ballistite grenade cartridge, description	175
Blind, grenade—	
— Definition of	124
— Destruction of: by whom permitted	131
— „ „ stores required	166
Bomber, definition of	123

G.		PAGE
Characteristics—		124
— Grenades		1
— Light automatic, details of		
D.		
Defence, small-arm anti-aircraft, general principles	177 <i>et seq.</i>	
Definition—		124
— Blind grenade		123
— Bomber		123
— Filling: grenades		123
— Fragmentation, grenades		123
— Premature		123
— Priming, grenades		123
— Segmentation, grenades		171
Demolition sets: assembling		123
Detonator, description of		
Detonators—		170
— Assembling with fuze		168
— Considerations regarding: general		170
— Safety precautions, when using		
Discharger—		175
— Gas, precautions against		308
— 2-inch, description		330
— 2½-inch, description		124
— Use of		
Dummy grenades—		174
— Filling of for use as live ones, not to be done	154 <i>et seq.</i>	
— Firing of: general instructions		148
— Precautions when throwing		153
— Range for firing		
F.		
Failures of grenades, reporting of		172
Filling, grenades: definition of		123
Fire—		193
— Control, A.A., rifle		209
— " L.A. sections		2
— Rate of for Lewis gun: average		177
— Small-arm against aircraft: value of		193
— Unit, A.A., rifle		123
Fragmentation, definition of		

Fuze—		PAGE
— Assembling with detonator		170
— Instantaneous, use of		167
— Safety precautions, when using		168
— " use of		167
G.		
Gas, precautions against when using grenades		175
Grenades—		
— Accidents with: chief causes		160
— Blinds: destruction of		166
— " " by whom permitted		131
— Cartridge, ballistite, description		175
— Characteristics of		124
— Destruction of by demolition		172
— Dummy, precautions when throwing		148
— " range for firing		153
— Failures and defects: reporting of		172
— H.E. employment of		125
— Live, definition of		123
— " inspection of prior to practice with		159
— " material, handling of: precautions		173
— " practice range for		160
— " practices, use of		159
— " safety precautions for practice		160
— " training with		158 <i>et seq.</i>
— Nature of		123
— No. 36, H.E.		316
— No. 54, H.E.		296 <i>et seq.</i>
— Safety precaution, the first		159
— Smoke, employment of		125 <i>et seq.</i>
— " storage of		174
— " 2-inch, description and firing of		313
— T.O.E.T.: details of		157
— Training: system of instruction		129 <i>et seq.</i>
Gun chest, L.G., contents of		260
H.		
Handling, Lewis gun: training in		95 <i>et seq.</i>
Holdall, Lewis gun: contents of		261
Holding, correct: importance of with L.A.		4

I.		PAGE
Instantaneous fuze, use of	...	167
Instruction—		
— Light automatic, A.A., subjects	...	200
— " " details of	...	3
— Grenade, subjects for	...	131
— Rifle, anti-aircraft training, subjects	...	184
— Training, anti-aircraft; general	...	178
L.		
Lewis gun—		
— Accessories, description of	...	252
— Characteristics of	...	1
— Component parts, list of	...	264
— Description, general	...	234 <i>et seq.</i>
— Equipment, complete set for infantry battalion	...	258
— Examination of: principal points in	...	247 <i>et seq.</i>
— Gun chests, contents of	...	260
— Handling: training in	...	85 <i>et seq.</i>
— Holdall, contents of	...	261
— Instruction in, subjects	...	3, 200
— Limbers: drill loading and unloading	...	273 <i>et seq.</i>
— Nomenclature of parts	...	233 <i>et seq.</i>
— Pack: drill loading and unloading	...	277 <i>et seq.</i>
— " equipment: load tables	...	287 <i>et seq.</i> , 293
— Packing limbered G.S. wagons	...	268 <i>et seq.</i>
— Rate of fire, average	...	2
— Spare parts and tools issued to infantry battalion	...	260 <i>et seq.</i>
Light automatic—		
— Anti-aircraft, accessories	...	336 <i>et seq.</i>
— Pack: training of sections	...	114
— " transport: changing from limber to be practised	...	117
Limbered G.S. wagon: packing with Lewis guns	...	266 <i>et seq.</i>
Load tables for Lewis gun pack equipment	...	287 <i>et seq.</i> , 293
M.		
Model aeroplane with pole and stand, description	...	343
O.		
Observation of fire, accuracy necessary	...	1

P.		PAGE
Pack, light automatic sections, training of	...	114
Practice—		
— Dummy grenades, conduct of	...	155
— Live grenade, conduct of	...	163
Premature, definition of	...	123
Priming: definition of	...	123
Projector spotlight, description and use of	...	345
R.		
Range—		
— Discipline, dummy grenades	...	155
— " live grenade practice	...	100 <i>et seq.</i>
— Dummy grenade firing	...	154
— Live grenade, danger area	...	160
S.		
Safety fuze: use of	...	167
Safety precautions—		
— Detonators, handling of	...	170
— Discharger, 2½-inch, when using	...	335
— " when using	...	312
— Dummy grenades: throwing	...	148
— Fuses: handling of	...	108
— Grenade, No. 36 H.E.	...	328
— Live grenades, handling	...	173 <i>et seq.</i>
Segmentation, definition of	...	123
Sentries, air, training of	...	183
Sights, A.A., description and fixing	...	336
Signals, warning, for use in case of air attack	...	183
Smoke grenades—		
— Employment of	...	125 <i>et seq.</i>
— Storage of	...	174
— 2-inch, description and firing of	...	313
Spotlight projector, use of and instructions	...	226
Stoppages—		
— Locating and remedying: training in	...	4
— Setting up: methods	...	38 <i>et seq.</i>

T.		PAGE
Targets—		
— Dummy grenade range	154	154
— Live grenade practice	160	160
— Spotlight projector : description	354	<i>et seq.</i>
Tests of elementary training—		
— Anti-aircraft, small-arms	230	<i>et seq.</i>
— Grenade training	187	187
— Lewis gun : instructions	117	<i>et seq.</i>
Training—		
— Anti-aircraft, small-arm	176	<i>et seq.</i>
— Grenade, basis of	124	124
— Handling Lewis gun : basis of	95	<i>et seq.</i>
— Light automatic section : details of	2	2
— " " " " sequence of	5	5
— Pack, light automatic sections	114	114
— Recognition : small-arm A.A. appliances	343	343

U.

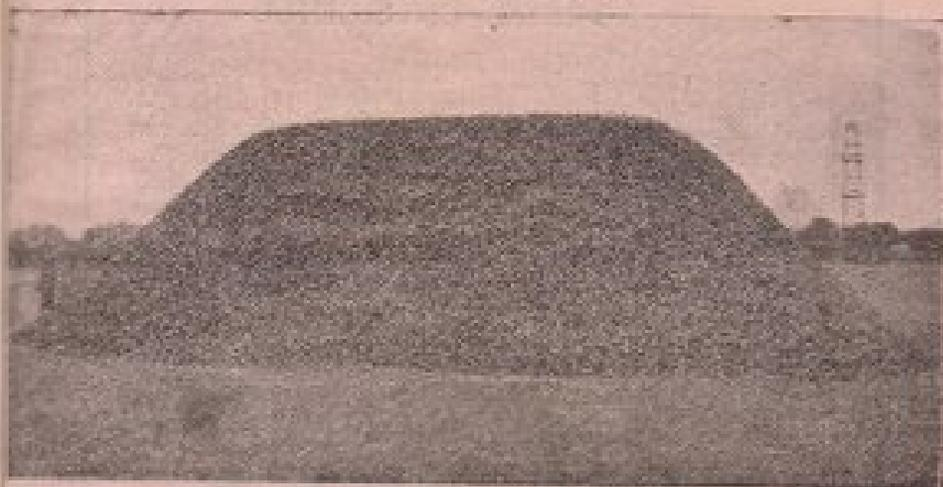
Unit, fire, A.A., rifle	193
--------------------------------	-----

Printed under the authority of His Majesty's Stationery Office
by William Clowes & Sons, Limited, London and Beccles.

(153) W.L. 36059—3539/2477. 85a. 10/31. W. C. & S., Ltd. Gp. 309.

WEST LONDON SHOOTING GROUNDS

Under Royal Patronage



The world's record heap of fired cartridges.

DISTINCTIVE FEATURES

GUN FITTING, PRACTICE and COACHING all the year round.
Within 20 minutes' car ride of Marble Arch. Trains every 5 minutes from all
parts of London to Ealing Broadway. Most up-to-date and best equipped.

GUN FITTING a speciality with the latest type of "Try-Gun"
—12, 16, and 20 bore.—Short and long barrels.

PRACTICE at every kind of game shooting.

COACHING by Experts.

PER VISIT

10/6

CARTRIDGES

15/- per 100

CLAY BIRDS

10/6 per 100

Illustrated Prospectus from

RICHMOND WATSON

PERIVALE, GREENFORD, MIDDLESEX

Telephone and Telegrams: EALING 9784

www.vickersmachinegun.org.uk

HOW TO SHOOT

By ROBERT CHURCHILL

Third Edition

In the present and third edition of HOW TO SHOOT—amplified and again largely re-written—the author has perfected his method of practical instruction.

He has supplied an almost completely new set of photographs to demonstrate in finer detail the process by which shooting skill can be obtained.

In this minute analysis of each component action from the moment the gun is raised to the time of firing, the author has condensed a lifetime's practical experience.

Price 5/3 post free, from E. J. CHURCHILL (Gun-makers) Ltd., 32 Orange Street, London, W.C.2

CHURCHILL'S NEW XXV GUN

"EASIER TO SHOOT WITH."

"LOOKS AS LONG AS A THIRTY INCH."

"FORWARD ALLOWANCES PRACTICALLY ELIMINATED."

"GIVES EXCEPTIONAL SHOOTING AT LONG RANGE."

"HANDLES LIKE A TWENTY AND SHOOTS AS HARD AS A TEN."

"ABSENCE OF DOWN-FLIP GIVES BETTER CHARGE ELEVATION."

"INCREASED STRENGTH — REDUCED WEIGHT — IMPROVED BALANCE."

32 ORANGE STREET, LEICESTER SQUARE,
LONDON, W.C.2

BE IN THE SWIM WEAR A JANTZEN



© Jantzen

Fit is style. Fit is comfort. And comfort's everything. That is why smart men and women at Deauville, Le Touquet, and the Lido choose a Jantzen. In the water, out of the water, they know it makes them look and feel their best. But stylish as the Jantzen looks, it is first and foremost a suit to swim in. Its long-fibred wool keeps you warm, and the exclusive Jantzen "elastic" stitch stretches exactly to your figure.

Ask at your nearest Store or Outfitter's to see this year's Jantzens in this year's colours

Jantzen

**STYLISH
BECAUSE
IT FITS**

C. J. LEMAIRE,
WALMER HOUSE, 296, Regent St., LONDON, W.1

